



FUEL MANAGEMENT SYSTEMS



DISPENSERS



KITS



PUMPS



METERS



NOZZLES

K600/4

FEATURES

- EASY TO INSTALL AND TO CALIBRATE
- VERSATILE
- HIGH PRECISION

The PIUSI K600/4 is an oval gear meter suitable for monitoring the delivery of fuels. This special version is particularly suitable for all applications in the industrial sector.

PERFORMANCE

15-150

L/MIN

FLOW RATE

20 BAR

MAX

OPERATING PRESSURE

± 0,5%

ACCURACY

0,2%

REPEATABILITY



K600/4



K600/4 PULSER



PACKAGING

CODE	WEIGHT		PACKAGING		
	KG	LBS	MM	INCH	PCS/BOX
METER					
00049700A	3,2	7	200X120X140	7,9X4,7X5,5	1
PULSER					
000473000	3,2	7	200X120X140	7,9X4,7X5,5	1



FILTRATION



TANK MONITORING



HOSE REEL



ACCESSORIES



MERCHANDISE



AIR



ANTIFREEZE



AdBlue®



BIODIESEL



DIESEL



FOOD



GASOLINE



GREASE



KEROSENE



OIL



WATER



WINDSCREEN

CHART

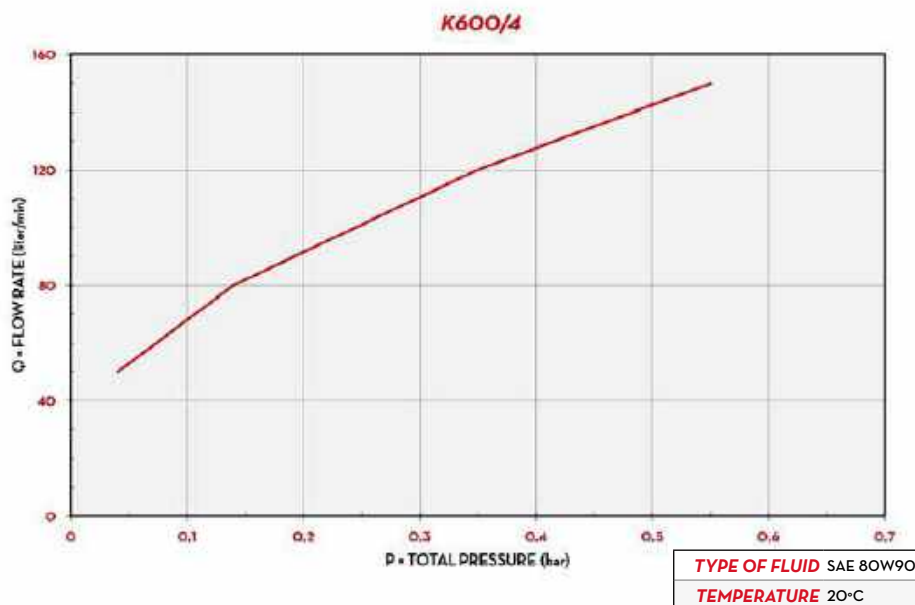

IN THE BOX

- K600/4 METER
- FLANGES
- INSTRUCTION MANUAL

DETAILS



5-DIGIT DISPLAY



OVAL GEARS

DIMENSIONS

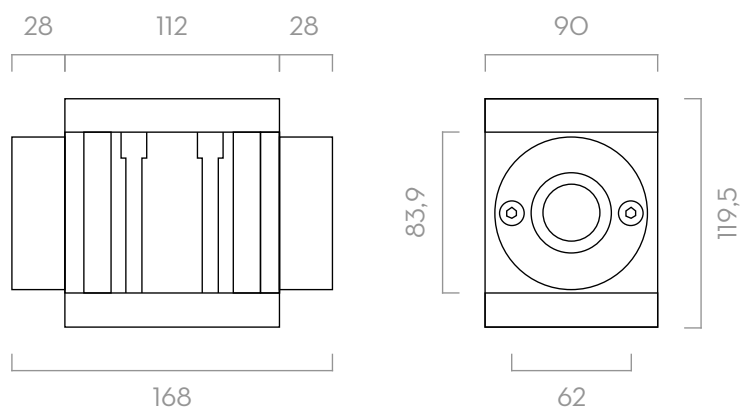

MATERIALS

- BODY: ALUMINIUM
- GEARS: TECHNOPOLYMER

Dimensions expressed in millimeters

TECHNICAL DATA

CODE	DESCRIPTION	FLUIDS TYPE	FLOW RATE		PULSER		PRESSURE		BATTERY N°2 X 1,5V (INCLUDED)	FLANGE	INLET / OUTLET	INLET FILTER
			L/MIN	GPM	P/L	GPM	BAR	PSI				
00049700A	K600/4	A B D O	15 - 150	3,9 - 39	-	-	20	284	YES	YES	11/2" BSP	YES
000473000	K600/4 PULSER	A B D O	15 - 150	3,9 - 39	26	98	20	300	NO	YES	11/2"	YES

UPON REQUEST AVAILABLE IN NPT VERSION.

K600/4