

PECO Series 75HTL

Installation and Operating Instructions

TITAN PURASEP®

HORIZONTAL GAS FILTER-SEPARATOR



A. GENERAL DATA

The Series 75HTL horizontal filter-separator is designed for separation of solid and liquid contaminants from a natural gas stream. It is available in all major design codes and certifications from 10" through 84" diameter sizes.

The vessel is separated into two stages. The first stage compartment contains replaceable filter cartridges mounted on supporting z-bar risers welded into a cartridge support plate which separates the first stage compartment from the second stage compartment. A quick-opening closure is provided on the first stage in order to change-out cartridges. The second stage compartment contains a high-efficiency mist extraction device which could be of the wire mesh, vane or Cyclotube® type.

Liquids will collect in both stages of the vessel. Liquid levels will need to be monitored and drained.

The cartridges in the vessel will become dirty or "spent" as solids collect on the cartridge. As this happens the differential pressure across the inlet and outlet flange connections of the vessel will begin to increase.

Installation and operation should be undertaken in accordance with all plant safety procedures and standard operating procedures of the end user by authorized personnel only.

If any difficulties are experienced during installation or in operation, consult Parker directly at (940) 325-2575 or your authorized, local Parker representative/distributor for assistance.

B. GENERAL ARRANGEMENT / FLOW

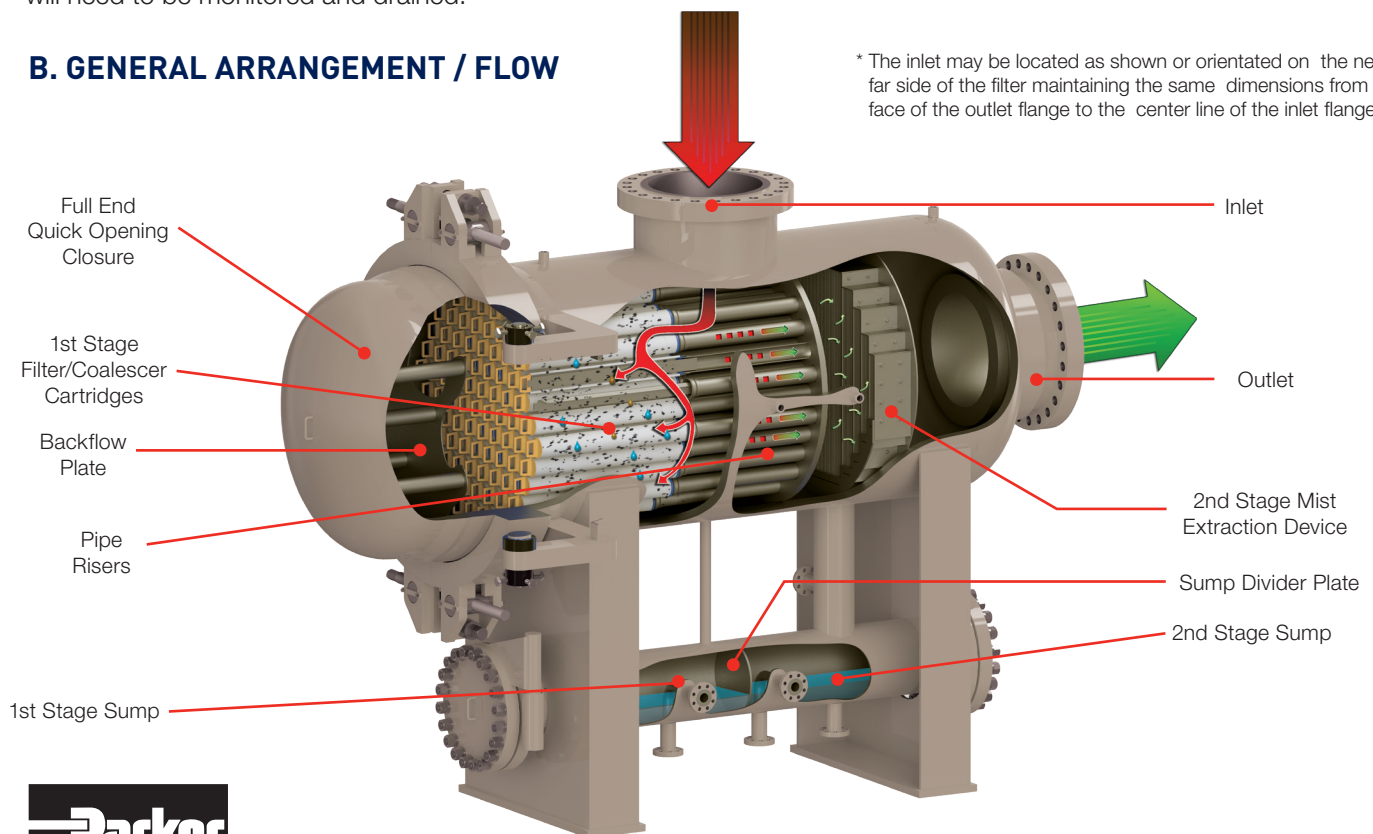

ENGINEERING YOUR SUCCESS.

C. INSTALLATION INSTRUCTIONS

1. Position the filter vessel on a flat surface and ensure there is adequate space in front of the closure to allow room to install/remove cartridges and above the closure for venting.
2. Connect inlet and outlet connections of filter vessel to piping of equal diameter. Check the filter vessel drawing to identify the location of each. It is recommended that the filter vessel be installed with by-pass and block valves to permit continued operation during cartridge changes.

⚠ Check to ensure that all blind flange bolting is properly torqued. Flange bolting is torqued at the factory, however may relax or loosen during shipment to the installation site.

3. Close inlet and outlet connection valves.
4. Open the vent valve.
5. The blow-down connection should be valved and piped to a pit, tank, or blow-down system.
6. Install any auxiliary equipment as required, such as differential pressure gauge and liquid level controls/drains. Since the vessel has two separate compartments, two sets of liquid control equipment are necessary. The controls must be piped independently and not be manifolded between the first stage compartment and second stage compartment because of the pressure differential between the two stages.

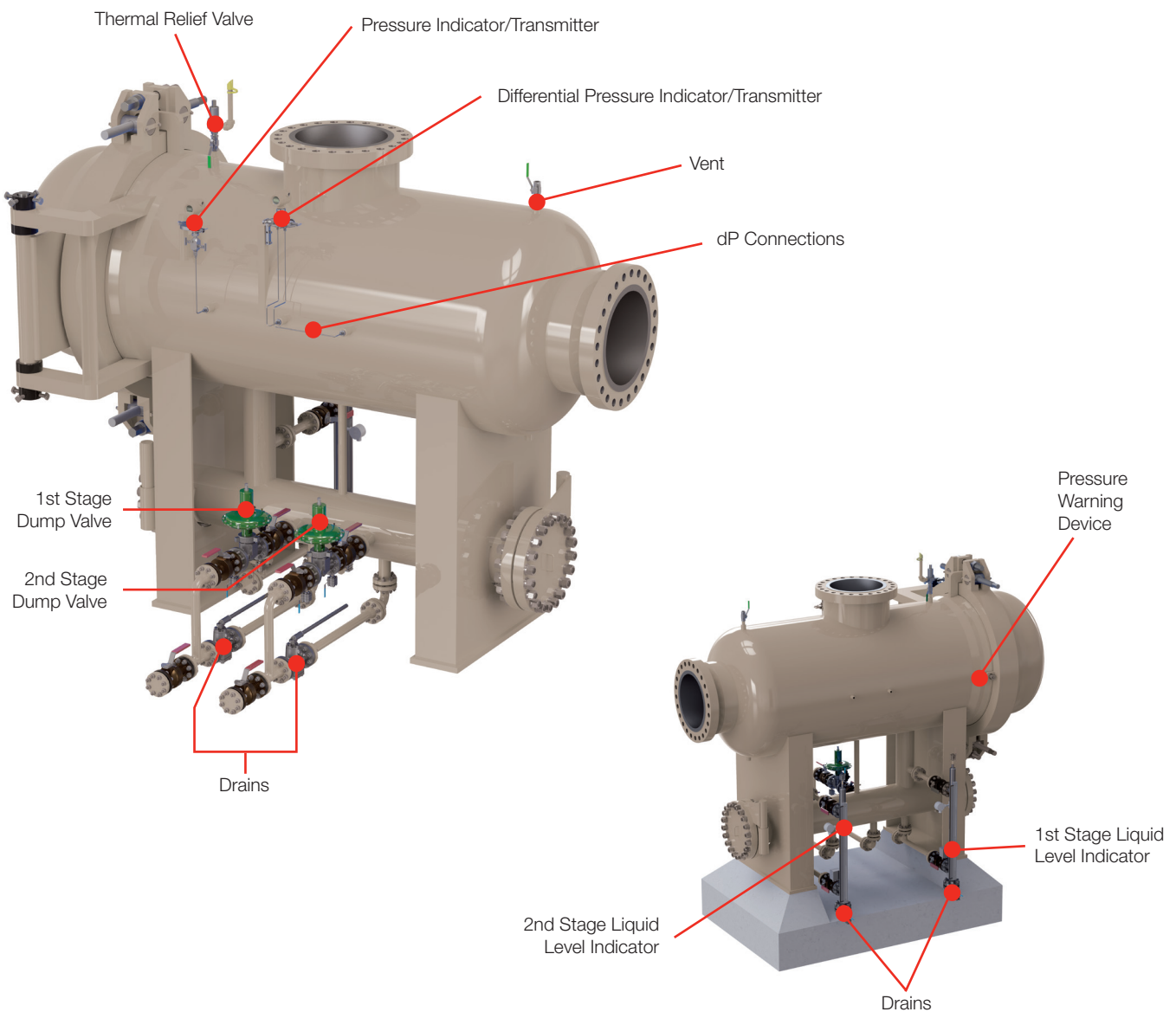

Illustration above is an example of a typical auxiliary package layout for a Series 75HTL. Depending on your vessel design your connections could vary. Auxiliary equipment may vary as well.

7. Two pressure taps are furnished on the vessel. One is located in the first stage, the other between the cartridge support plate and the second stage mist extraction device. It is extremely important that an accurate differential pressure gauge be installed on the vessel. Pressure drop is the only indicator that the operator has to tell him/her when the filter vessel should be blown-down or by-passed to change the filter cartridges.

8. Open the filter vessel closure **(according to closure manufacturer's procedures)** and inspect the inside of the vessel. Verify the internals have not been damaged and that the O-ring for the closure is in place. Verify the cartridges are seated properly on the risers and that each cartridge seal is fully engaged.

9. Cartridge installation:
This particular series uses EZ-Align™ which provides for quick cartridge change-out. The handle side of the cartridge is keyed to fit into a slot at the end of the z-bar riser. This design offers many benefits including:

- no tools required to secure cartridges,
- holds the cartridge concentric with the sealing surface during entire time of operation to ensure cartridges do not sag,
- state-of-the-art pressure loading enhancement seal to prevent gas bypass,
- minimizes maintenance time and costs.

10. Inspect the closure gasket to make sure it is new and in good condition. Make sure it is seated in the closure groove correctly.

11. Close the closure **(according to closure manufacturer's procedures)**.

12. Prior to filling the filter vessel with gas, verify that the operating pressure and temperature are within the design limits of the filter vessel. The design conditions can be found on the filter vessel nameplate.

13. Review and follow all operating company safety procedures for filter operation.

14. Follow all operating company safety and lockout/tag-out procedures.

15. Verify that inlet and outlet connection valves are closed and that vent valve is open.

16. **Slowly and partially** open the inlet connection valve and introduce the gas stream into the filter vessel. Allow gas to purge air from the filter vessel through the vent valve. Purging should only take a few seconds.

17. Close vent valve.

18. Check for leaks. Should a leak occur, close inlet valve immediately and determine cause of leak.

! Make sure to fully depressurize the vessel prior to attempting to fix the leak.

19. Once no leaks are found, check to be sure that all auxiliary equipment is ready for operation.

*Pressure gauge, liquid level controls and automatic dump valves are optional features that can be supplied by the manufacturer or can be purchased separately by the end user.

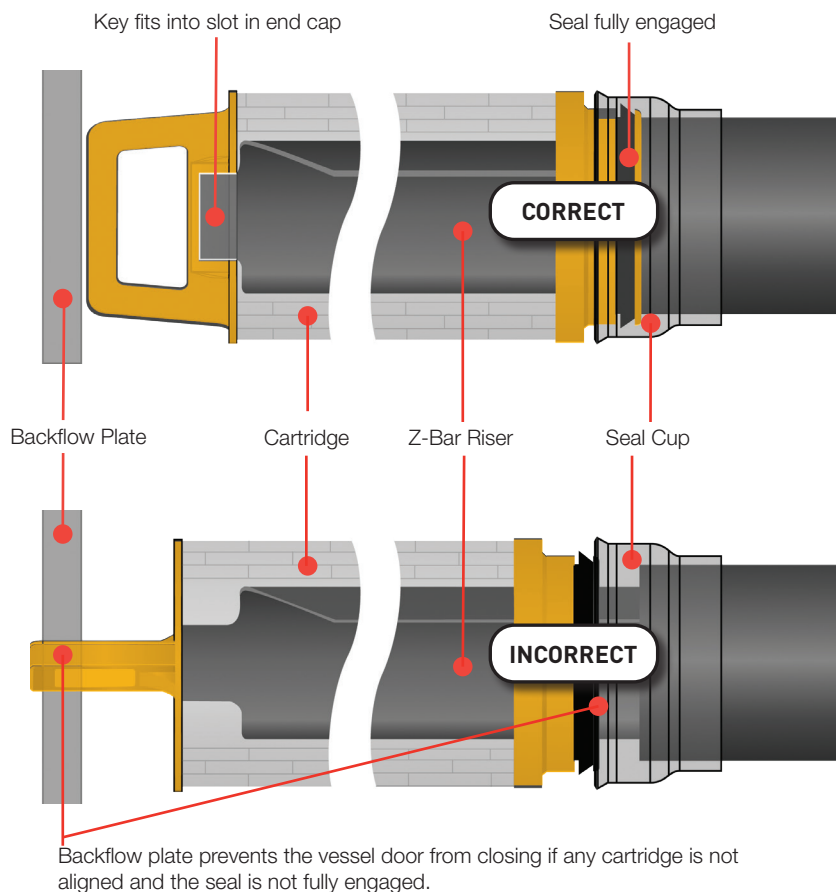

CARTRIDGE ALIGNMENT

D. OPERATING INSTRUCTIONS

1. Once the filter vessel is full of gas and no leaks are found, open the inlet valve all the way.
2. **Slowly** open the outlet connection valve and begin flow through vessel. Flow should be set based on recommended flow rate provided during sizing.
3. Monitor differential pressure across the inlet/outlet. The filter is typically designed for 2 psid (0.14 bar) or less differential pressure at start-up at normal operating conditions. Once the cartridge becomes wet/saturated, the differential pressure may increase slightly. The cartridges have to become completely saturated before stripping liquid. This may take 24 hours or longer, depending on the amount of free liquid in the stream.
4. The liquids collected in both compartments of the vessel will need to be drained. Check the liquid level regularly to verify operation of automatic drain or, if there is no automatic drain, open manual drain in liquid reservoir and drain liquid as required. Never let the liquid level get above the top of the sump section.
5. As the cartridge loads with solids, the differential pressure across the filter vessel is expected to increase. The cartridge should be replaced when the differential pressure reaches 12-15 psid (0.8-1.0 bar) at normal operating pressure or every year, whichever comes first.
 - Do not backflow the filter vessel. A high velocity flow inside the cartridges could cause damage or cause the cartridge seal to become disengaged.
 - If the filter vessel has been operating at a flow rate far below its design capacity for any period of time, it should be blown down and removed from service for inspection and clean-out, regardless of pressure drop, before increasing to operating at a maximum capacity flow.
 - An excessive pressure drop across the second stage liquid separator device signifies that the filter is being loaded with heavy hydrocarbons or paraffin. The filter should be taken out of service and the cartridges removed. Open all the drains, including the drain in the second stage compartment. Low-pressure steam can be introduced in the supply coupling located in the second stage compartment to clean the liquid separator device. Steaming should continue for approximately two hours.
 - Do not clean the filter vessel with steam injected into the first stage compartment with the cartridges still installed. Make sure cartridges are removed prior to any steaming performed.
 - If the solids being removed from the gas are susceptible to causing combustion with air (i.e. iron sulfides/black powder), the filter vessel may be flooded with water and then drained before the closure is opened and spent cartridges are removed. This will reduce the risk of cartridges combusting.

E. MAINTENANCE INSTRUCTIONS – CHANGING SPENT CARTRIDGES

1. Review all operating company safety procedures prior to cartridge replacement operations.
2. Follow all operating company safety and lockout/tag-out procedures.
3. Ensure that all liquids are drained off the vessel before proceeding with the cartridge replacements.
4. Open filter bypass valve (if available) and then isolate the filter vessel by closing the inlet and outlet connection valves.
5. Open the blow-down connection or closure vent valve to relieve any pressure on the vessel.



Ensure that the filter vessel pressure is at atmospheric pressure prior to proceeding.

6. Open the closure (**according to closure manufacturer's procedures**).
7. Remove dirty (spent) cartridges.



Dispose of spent cartridges in accordance with plant procedures and applicable laws and regulations for disposal in your area.

8. Inspect and clean the filter vessel as needed. Make sure all debris is cleaned from the cartridge sealing surfaces. Make sure no cartridge gasket seals have been left in vessel during cartridge removal. If any vessel damage is found notify Parker immediately. Do not operate vessel until damage is fixed.
9. Install new cartridges and ensure proper sealing on the riser post and seat. This particular series uses EZ-Align™ which provides for quick cartridge change-out. The handle side of the cartridge is keyed to fit into a slot at the end of the z-bar riser.

Slide open end of cartridge over z-bar and push the cartridge until the end cap with chevron gasket is fully inserted into the cup. The top cap handles (and arrow marking) should be in the vertical (up/down) position. You should feel the opening in the top cap engage with the slot on the z-bar riser.



The use of original OEM cartridges is highly recommended to ensure the best overall performance of the filter. Replacement cartridges can be ordered through your local Parker distributor. The cartridge Item Number and Series Description can be found in the Manufacturer's Data Book supplied with your vessel.

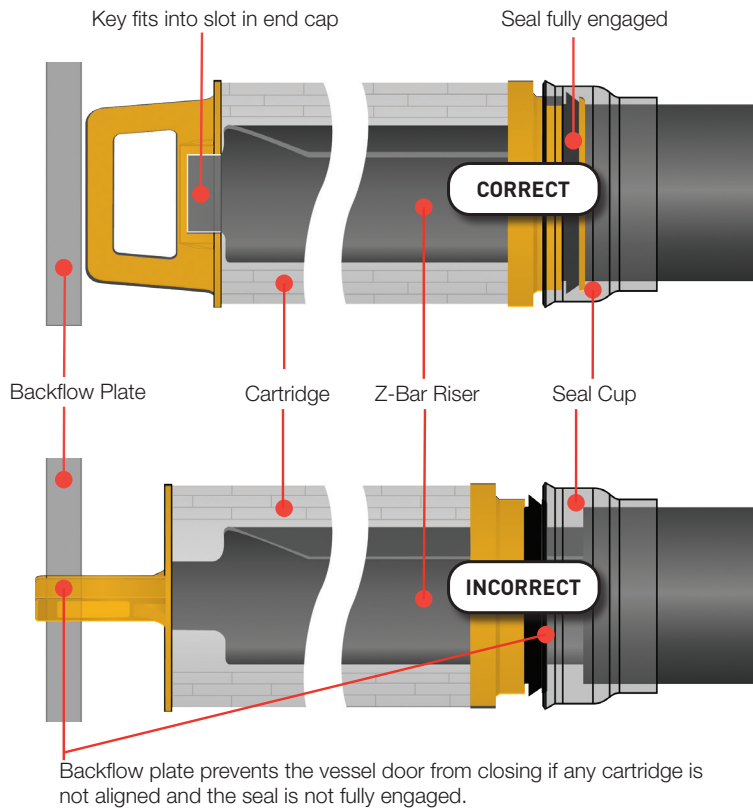

CARTRIDGE ALIGNMENT

10. Install a new closure gasket. The use of original closure manufacturer's gasket is highly recommended to ensure the best overall performance of the filter. Replacement gaskets can be ordered through your local Parker distributor. The closure gasket Item Number and Series Description can be found in the Manufacturer's Data Book supplied with your vessel and also on the vessel nameplate.

 **Installation of a new closure gasket during each cartridge change is highly recommended.**

11. Close the closure **(according to closure manufacturer's procedures)**.

12. Make sure vent valve is open.

13. Make sure inlet and outlet valve are closed.

14. **Slowly and partially** open the inlet connection valve and introduce the gas stream into the filter vessel. Allow gas to purge air from the filter vessel through the vent valve. Purging should only take a few seconds.

15. Close vent valve.

16. Check for leaks. Should leak occur, close inlet valve immediately and determine cause of leak.

 **Make sure to fully depressurize the vessel prior to attempting to fix the leak.**

17. Once no leaks are found, check to be sure that all auxiliary equipment is ready for operation.

18. Repeat operating instructions in section B.

F. SUMMARY DATA

Recommended Cartridge Change-out Differential Pressure:
12-15 psid (0.8-1.0 bar)

Maximum Cartridge Differential Pressure at Collapse:
25 psid (1.7 bar) without metal core
50 psid (3.4 bar) with metal core

Note: The following pressure information is provided as a minimum guideline. Due to the variety of cartridge models that can be used in vessel, it is strongly suggested to refer to the specific cartridge data sheet for further detailed pressure information. To prevent damage, never exceed the maximum allowable differential pressure of the cartridge support plate in the vessel.



PEACH® DynaSep™

Cartridge Series EZ-PCHG

Available in polyester or polypropylene media and micron ratings of 0.1, 0.3, 0.5, 1, 5 and 10.