



FUEL MANAGEMENT SYSTEMS



DISPENSERS



KITS



PUMPS



METERS



NOZZLES

# EXGO!

## FEATURES

- CONTINUOUS DUTY
- COMPACT AND STURDY DESIGN
- EASY TO INSTALL
- BUILT-IN BYPASS
- THERMAL PROTECTION
- REDUCED NOISE LEVEL
- SELF-PRIMING

The PIUSI EX GO! is a compact and sturdy ATEX vane pump; expressly engineered to work safely in potentially explosives atmosphere. As the name says, this continuous duty DC pump is easy to place thanks to the small sizes and represents the ideal solution for small mobile tanks thanks to the remote control (on/off switch) and long cables (5mt EXGO! Switch - 3mt EXGO! without Switch). It can be used to dispense several fluids: Gasoline and E15, Diesel, Paraffinic Biodiesel. It is equipped with built-in bypass valve and a thermal protected motor.

### PERFORMANCE

UP TO  
**32 L/MIN**

FLOW RATE

MAX  
**1,2 BAR**

OPERATING PRESSURE

**DC 12V**  
VOLTAGE  
POWER

**CONTINUOUS  
DUTY**



EXGO!





EXGO! BATTERY KIT



OUR PUMPS COMPLIES WITH THE FOLLOWING MARKING ATEX/IECEx  
EX50 EX75 EX50 EX75

II	2	G	Ex	d	db	IIA	IIB	T4	Gb
GROUP	CATEGORY	TYPE OF EXPLOSIVE ATMOSPHERE	PERMANENT PREFIX	PROTECTION METHOD		GAS GLASS		TEMPERATURE CLASS	EQUIPMENT PROTECTION LEVEL

### PACKAGING

CODE	WEIGHT		PACKAGING			N. BOX / EUROPALLET	
	KG	LBS	MM	INCH	PCS/BOX		
FO0381020	5,43	12	280X160X140	-	1	-	-
FO0381500	5,43	12	280X160X140	-	1	-	-
FO0225X00	9,8	21,6	350X350X180	-	1	H	



FILTRATION



TANK MONITORING



HOSE REEL



ACCESSORIES



MERCHANDISE

INDEX



ANY BIODIESEL



AIR



ANTIFREEZE



AdBlue®



BIODIESEL



DIESEL



FOOD



GASOLINE



GREASE



KEROSENE



OIL



WATER



WINDSCREEN

## CHART

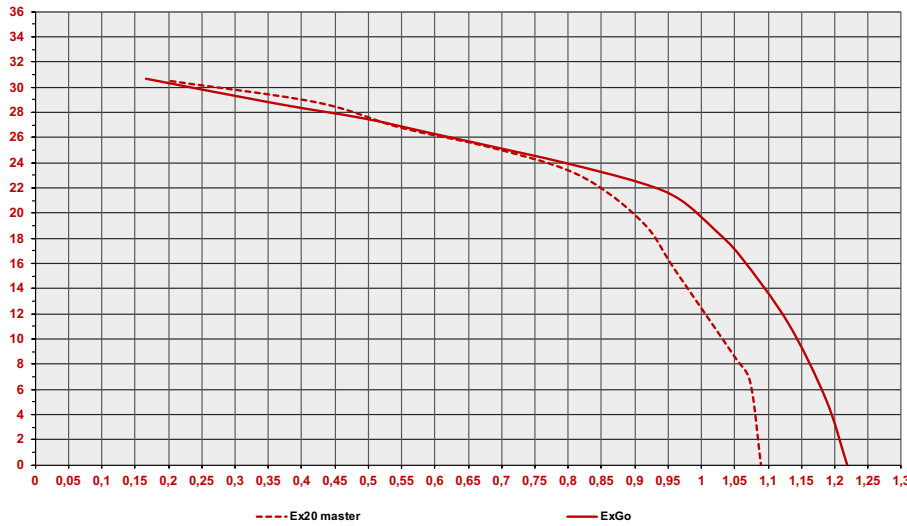

## DIMENSIONS

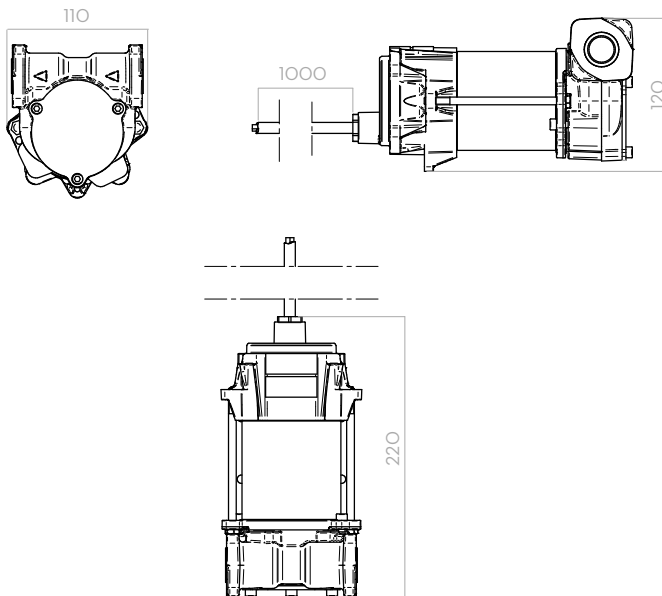

Dimensions expressed in millimeters

## IN THE BOX

- EXGO! PUMP/EXGO BATTERY KIT
- DELIVERY HOSE 2,5 MT (ONLY EXGO BATTERY KIT)
- SELF2000 NOZZLE (ONLY EXGO BATTERY KIT)
- INSTRUCTION MANUAL

## DETAILS

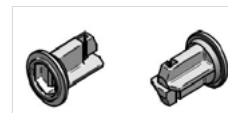

BUILT- IN BY-PASS VALVE



SWITCH ON/OFF



ELECTRIC CABLE WITH CLAMPS



SELF 2000 NOZZLE WITH DELIVERY HOSE 2.5M (ONLY EXGO BATTERY KIT)

## MATERIALS

- BODY: CAST IRON
- ROTOR: SINTERED STEEL
- VANES: PPS
- SEAL: FKM
- SHAFT: STEEL

## TECHNICAL DATA

CODE	DESCRIPTION	FLUIDS TYPE	FLOWRATE		VOLTAGE			FUSIBLES	DUTY CYCLE	NOZZLE	RPM	HOSE		IN	OUT	CHECK FILTER
			L/MIN	GPM	DC VOLT	POWER WATT	AMP. MAX.					AMPERE	MINUTE			
FO0381020	EXGO! 12V DC ATEX	B D G K	32	8,5	12	108	9A	25A	CONTINUOUS	-	1400	-	-	3/4"	3/4"	-
FO0381500	(EX) EX20 12V DC (W/O SWITCH)	B D G K	32	8,5	12	108	9A	25A	CONTINUOUS	-	1400	-	-	3/4"	3/4"	-
FO0225X00	EXGO BATTERY KIT	B D G K	32	8,5	12	108	9A	25A	CONTINUOUS	SELF 2000	1400	2,5M	3/4"	3/4"	3/4"	SI