



# CUBE B.SMART

## FEATURES

- STURDY STRUCTURE
- COMPACT DESIGN
- NATIVE WITH B.SMART CLOUD SOFTWARE
- KIT UPGRADE 1.0/2018 AVAILABLE
- IP55

The CUBE B.SMART fuel dispenser, available in the 70 and 90 litre/min versions with both AC and DC supply, is equipped with a self-priming vane pump with built-in bypass that ensures high performance. The anti-vibration support of the diesel dispenser guarantees silent operation and practicality, while the mechanical seal and the thermal protection of the induction motor against overheating make the product reliable and safe. CUBE B.SMART is equipped with an automatic nozzle with swivel connection. The installation of the mesh filter on the suction side ensures the pump longevity, as it prevents foreign bodies from ending up in the rotor and causing a blockage and consequent damage.

### PERFORMANCE

<b>UP TO</b> <b>90 L/MIN</b>	<b>AC/DC</b> <b>VOLTAGE</b>
FLOW RATE	POWER
<b>± 0,5%</b>	<b>BLUETOOTH</b>
ACCURACY	CONNECTION

**NEW**  
Upgrade your MC hardware to B.SMART with KIT UPGRADE CUBE 1.0/2018



CUBE B.SMART



### PACKAGING

CODE	WEIGHT		PACKAGING			N. BOXES / EUROPALLET	
	KG	LBS	MM	INCH	PCS/BOX	X	

#### AC VERSION

FO0598000	24	53	380X380X480	15,0X15,0X18,9	1	-	-
FO0598020	24	53	380X380X480	15,0X15,0X18,9	1	-	-
FO0598040	24	53	380X380X480	15,0X15,0X18,9	1	-	-
FO0598010	24	54	380X380X480	15,0X15,0X18,9	1	-	-
FO0598030	24	54	380X380X480	15,0X15,0X18,9	1	-	-
FO0598050	24	54	380X380X480	15,0X15,0X18,9	1	-	-

#### DC VERSION

FO0598A00	23	50	380X380X480	15,0X15,0X18,9	1	-	-
FO0598A20	23	50	380X380X480	15,0X15,0X18,9	1	-	-
FO0598A40	23	50	380X380X480	15,0X15,0X18,9	1	-	-
FO0598A10	23	50	380X380X480	15,0X15,0X18,9	1	-	-
FO0598A30	23	50	380X380X480	15,0X15,0X18,9	1	-	-
FO0598A50	23	50	380X380X480	15,0X15,0X18,9	1	-	-



FILTRATION



TANK MONITORING



HOSE REEL



ACCESSORIES



MERCHANDISE



AIR



ANTIFREEZE



AdBlue®



BIODIESEL



DIESEL



FOOD



GASOLINE



GREASE



KEROSENE



OIL



WATER



WINDSCREEN

## CHART

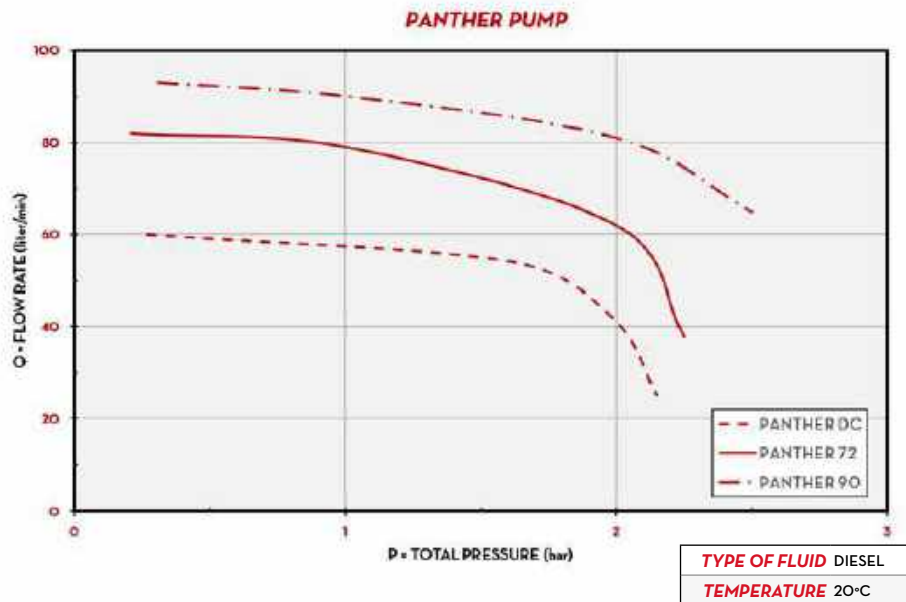

## IN THE BOX

- CUBE B.SMART DISPENSER
- AUTOMATIC NOZZLE
- DELIVERY HOSE
- DRIVER ACCESS ADD-ON
- INSTRUCTION MANUAL

## DETAILS



## DIMENSIONS

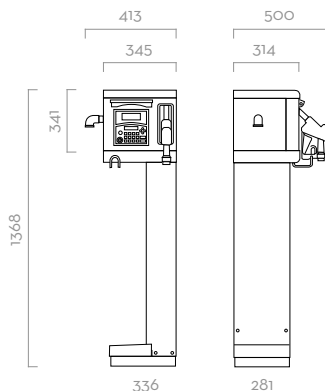

Dimensions expressed in millimeters

## MATERIALS

- **PUMPS:**  
PANTHER AC PAG. 102  
PANTHER DC PAG. 114
- **METER:**  
K600/3 PAG. 134
- **NOZZLE:**  
AUTOMATIC NOZZLE PAG. 158

## TECHNICAL DATA

CODE	DESCRIPTION	FLUIDS TYPE	FLOW RATE		VOLTAGE			PUMP	METER	NOZZLE	FILTER	INLET	HOSE		
			L/MIN	GPM	AC V/HZ	DC VOLT	POWER WATT						AMP. MAX.	TYPE	Ø
<b>AC VERSION</b>															
FO0598000	CUBE 70 230V B.SMART 10 DRIVERS	D	70	18	230 V	50 HZ	900 W	4,2 A	PANTHER 72	K600/3	A60	NO	1"	4M	25MM
FO0598020	CUBE 70 B.SMART 230 V 20 DRIVERS	D	70	18	230 V	50 HZ	900 W	4,2 A	PANTHER 72	K600/3	A60	NO	1"	4M	25MM
FO0598040	CUBE 70 B.SMART 230 V 50 DRIVERS	D	70	18	230 V	50 HZ	900 W	4,2 A	PANTHER 72	K600/3	A60	NO	1"	4M	25MM
FO0598010	CUBE 90 230V B.SMART 10 DRIVERS	D	90	24	230 V	50 HZ	900 W	4,9 A	PANTHER 90	K600/3	A120	NO	1"	4M	25MM
FO0598030	CUBE 90 B.SMART 230V 20 DRIVERS	D	90	24	230 V	50 HZ	900 W	4,9 A	PANTHER 90	K600/3	A120	NO	1"	4M	25MM
FO0598050	CUBE 90 B.SMART 230V 50 DRIVERS	D	90	24	230 V	50 HZ	900 W	4,9 A	PANTHER 90	K600/3	A120	NO	1"	4M	25MM
<b>DC VERSION</b>															
FO0598A00	CUBE 12 V B.SMART · 10 DRIVERS	D	56	15	12 V		300	35	PANTHER DC	K600/3	A60	NO	1"	4M	25MM
FO0598A20	CUBE 12 V B.SMART · 20 DRIVERS	D	56	15	12 V		300	35	PANTHER DC	K600/3	A60	NO	1"	4M	25MM
FO0598A40	CUBE 12 V B.SMART · 50 DRIVERS	D	56	15	12 V		300	35	PANTHER DC	K600/3	A60	NO	1"	4M	25MM
FO0598A10	CUBE 24 V B.SMART · 10 DRIVERS	D	70	18	24 V		420	25	PANTHER DC	K600/3	A60	NO	1"	4M	25MM
FO0598A30	CUBE 24 V B.SMART · 20 DRIVERS	D	70	18	24 V		420	25	PANTHER DC	K600/3	A60	NO	1"	4M	25MM
FO0598A50	CUBE 24 V B.SMART · 50 DRIVERS	D	70	18	24 V		420	25	PANTHER DC	K600/3	A60	NO	1"	4M	25MM

# CUBE B.SMART