

AIR OPERATED DOUBLE DIAPHRAGM PUMPS



Innovative | Unique | Simple | Reliable | Durable | Compact | Efficient | Quiet | Versatile



Headquarters Offices and Technical Centre in Gijón (Spain)

SAMOA QUALITY AND LEADERSHIP

FLUID HANDLING TECHNOLOGY

SAMOA, a privately owned company, is a leading European manufacturer of equipment for fluid transfer, dispensing, dosing, recovery and inventory control. SAMOA designs and manufactures volume flow meters, hose reels, air operated piston pumps and air operated diaphragm pumps, including innovative Directflo® diaphragm pumps.

PRODUCT DEVELOPMENT

Product research and development is a fundamental part of SAMOA's philosophy. We are in permanent contact with the market to identify new customer needs, that we satisfy with product improvements and new products.

MANUFACTURING

SAMOA's headquarters have been in Gijón, on the Spanish North Coast, for over 60 years. SAMOA's manufacturing facilities are modern and equipped with the latest state-of-the-art production equipment and technology. We are committed to design and manufacturing excellence, environmental sustainability and a healthy and safe workplace; our work processes and facilities are consequently ISO 9001, ISO 14001 and OHSAS 18001 certified.

DISTRIBUTION

Our products are available through a network of knowledgeable distributors. This global network provides a sales and consulting service, to identify the products that best meet each customer's needs, and when required offers after sales service to ensure the long and satisfactory use of our equipment.

GLOBALLY COMPETITIVE

Our continuous product improvement process ensures that our products meet customer requirements worldwide, including in even the most demanding applications and environments. As a result, we are proud to say that SAMOA products are reliably working away, night and day, in more than 100 countries.



Research & Development and Manufacturing facility in Gijón (Spain)



SAMOA: Leading Through Innovation

- ▶ RESEARCH & DEVELOPMENT
- ▶ PRODUCT DESIGN & ENGINEERING
- ▶ PRODUCT PROTOTYPING & TESTING
- ▶ ROBOTISED CNC MANUFACTURING
- ▶ QUALITY CONTROL INCLUDING FUNCTIONAL TESTING
- ▶ RAPID & RELIABLE ORDER FULFILLMENT
- ▶ EFFICIENT AFTER-SALES SERVICE



DIRECTFLO® PUMPS APPLICATIONS



Process industry.



Wood varnish spraying.



Printing industry.



Ink additive dosing.



Cutting oil solution transfer.



Submersed pump application.



Cement additive dosing.



Leather industry.



Flexographic ink.



Chemical products dosing.



Paint application.



Gravure ink.

DIRECTFLO® PUMPS

Air operated double diaphragm pumps for dosing, spraying, transferring, evacuating and distributing a wide variety of fluids.

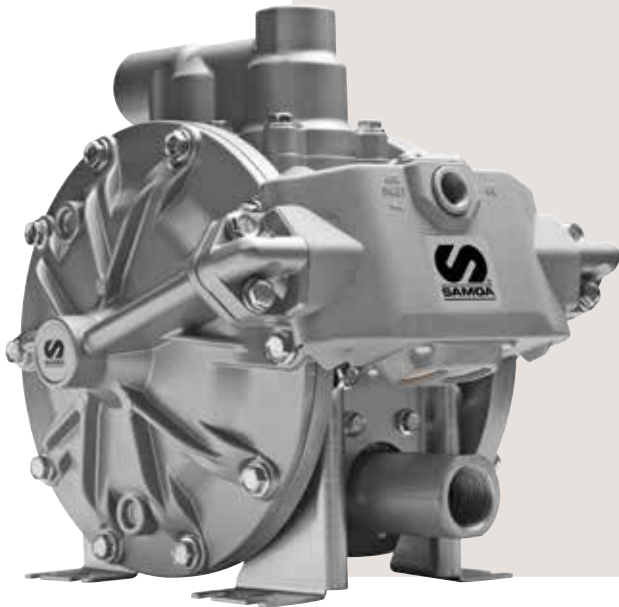

REVOLUTIONARY DIRECTFLO® TECHNOLOGY

Directflo® pumps are based in an "inside-out" technology: the fluid is pumped through the centre of the pump and the compressed air acts on outside face of the diaphragms.

- EXTREMELY FAST CHANGE OVER
- DIAPHRAGMS DO NOT FULLY FLEX WHICH GREATLY EXTENDS LIFE

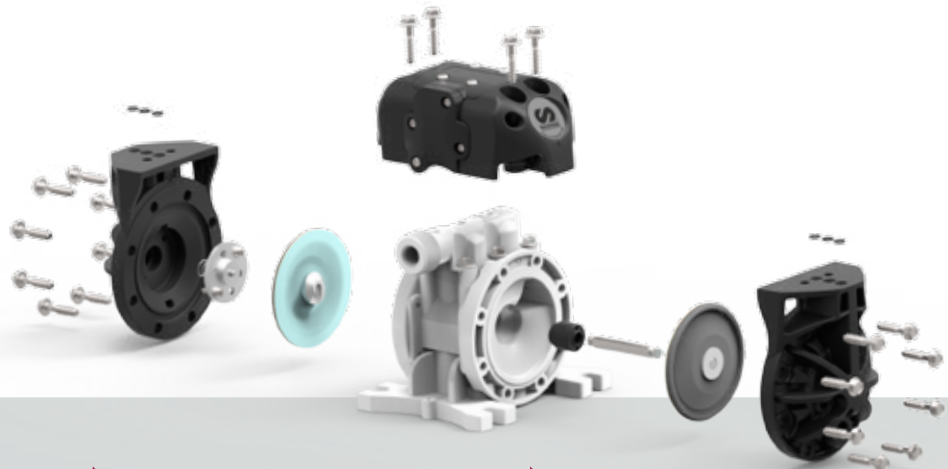
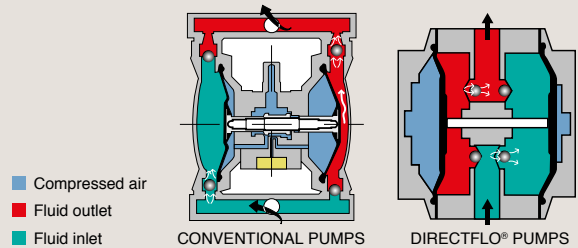

Better by design

▶ PROVEN SUPERIOR PERFORMANCE

- Superior dry suction
- Non icing
- Reduced pulsation
- Variable flow rate and pressure by adjusting the air pressure

▶ RELIABLE

- Superior start up reliability
- No stalling
- Tolerates dry, damp, dirty or oily air.
- Leak free operation through the pump's life

▶ SMOOTH RUNNING

- Gentle pumping
- Reduced pulsation
- Fewer vibrations

▶ COST EFFICIENT

- Reduced air consumption
- Reduced internal pressure drop

▶ COMPACT

- One-piece fluid section
- Integrated muffler

▶ SIMPLE

- Fast and easy maintenance
- Easy operation
- Orientable air inlet

▶ DURABLE

- First quality materials
- Long diaphragm life
- Short stroke and robust construction

WIDE CHOICE OF MATERIALS

SAMOA offers a wide range of materials to withstand abrasion, temperature and chemical compatibility satisfying the most demanding applications.

DIRECTIONAL AIR VALVE AND AIR CHAMBER COVERS

Polypropylene
Aluminium

Conductive polypropylene is used in groundable ATEX pumps.

WETTED PUMP BODY

Polypropylene
Acetal
PVDF (Kynar® or Solef®) - Polyvinylidene Fluoride
Aluminium
Stainless Steel - AISI 316

Conductive plastic materials are used in groundable ATEX pumps.

PUSH ROD

Stainless Steel - AISI 420
Hastelloy® C

SEALS

EPDM - Ethylene Propylene Diene Monomer Rubber
FKM (Viton®) - Fluoroelastomer
PTFE (Teflon®) - Polytetrafluoroethylene
Buna-N - Nitrile Butadiene Rubber

CHECK VALVE SEATS

Polypropylene
Acetal
PVDF (Kynar® or Solef®) - Polyvinylidene Fluoride
Buna-N - Nitrile Butadiene Rubber
TPE (Hytrel®) - Thermoplastic Elastomer
Santoprene®
Aluminium
Stainless Steel - AISI 316

CHECK VALVE BALLS

PTFE (Teflon®) - Polytetrafluoroethylene
Acetal
Buna-N - Nitrile Butadiene Rubber
Stainless Steel - AISI 316

LONG LIFE DIAPHRAGMS

PTFE (Teflon®) - Polytetrafluoroethylene
TPE (Hytrel®) - Thermoplastic Elastomer
Santoprene®
Buna-N - Nitrile Butadiene Rubber

Not all materials listed are available for all models and sizes. Check materials available to each model.

DIAPHRAGM PUMP OPTIONS



EXTERNALLY DRIVEN PUMP

EXTERNALLY DRIVEN PUMP

DF pumps without the air valve module and end of stroke sensors to be controlled with an external device like a PLC for their use in dosing applications.

INDUCTIVE SENSORS

Used with externally self-driven pumps, the sensor sends a signal to a PLC to reverse the air direction. Sensors assure that the diaphragms complete their stroke and they allow to regulate the pump speed. The sensors are available with NPN, PNP or ATEX (NAMUR) connectors.

END OF STROKE SENSOR

It allows counting the number of cycles of a pump.

REMOTE AIR EXHAUST

Threaded connection replaces the standard bronze sintered muffler for connecting a hose for remote air exhaust. 3/8" connection for DF30, DF50, DF100, DC20, DC30 and DC50 pumps; 3/4" for DP200 pumps and 1" for DF250 pumps.



REDUCED NOISE MUFFLER







REDUCED NOISE MUFFLER

Replaces the standard brass disc muffler to further reduce the noise produced by compressed air expansion.

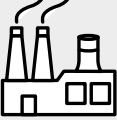
UV INK

Special conductive PTFE sleeve that allows the pump to be used with UV inks.

MARKETS SERVED

 CHEMICAL, PETROCHEMICAL AND REFINERIES	 VEHICLE PRODUCTION AND MAINTENANCE	 CONSTRUCTION AND MINING
 CERAMIC	 SURFACE TREATMENTS	 PAINT AND COATINGS
 PRINTING AND PACKAGING	 PULP AND PAPER CONVERTERS	 HYGIENIC-SANITARY APPLICATIONS
 WATER PROCESS	 WASTEWATER	 METALWORKING

For further details of markets served and applications please see page 35.

APPLICATIONS

FLUID TRANSFER AND DISPENSING
 FLUID EVACUATION
 DOSING/BLENDING/FORMULATION
 FLUID RECIRCULATION
 SUPPLY FOR LOW PRESSURE SPRAY
 FLUID FLUSHING/ CLEAN IN PLACE (CIP)
 PUMPING SAMPLES
 FILTER & FILTER PRESS FEEDING
 SLURRY HANDLING
 TANK/BARREL FILLING & EMPTYING

FLUIDS

Acids Alkalis Alcohols Solvents Water based fluids Chemicals Fuels & oils Inks, paints & varnishes Additives Etc.	Abrasive Corrosive Hazardous Flammable Solids in suspension Shear sensitive Medium viscosity
----------------------------------------------------------------------------------------------------------------------------------------------	----------------------------------------------------------------------------------------------------------------



SAMOA DIRECTFLO® PUMPS

CUSTOM

Plastic: DC20 - DC30 - DC50

Reliable Compact Design



- ▶ Ideal for dosing applications
- ▶ New air motor with an unbalanced spool valve design
 - Low Start up pressure reliability.
 - Adjustable fluid flow rate by regulating the air pressure.
- ▶ Compact
 - For OEM installation applications and industrial processes.
- Built-in air exhaust**
 - Possibility to connect a hose for remote exhaust or super-silent muffler.
- Orientable ports**
 - DC20 inlet and outlet ports can be rotated.

1/4" to 1/2"
Up to 50 l/min
(14 US gal/min)

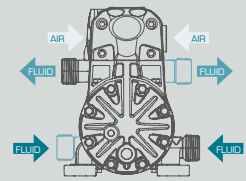

FUNCTION

Plastic: DF30 - DF30T - DF50 - DF50T - DF100
Metal: DF50 - DF100 - DF250

Original Directflo® Technology



- ▶ Ideal for standard applications
- ▶ Wide range of sizes available
- ▶ Improved ball valve guides design
- ▶ In line servicing
 - Easy.
 - Quick.
 - Cost saving.
- ▶ Reach higher flow rates - Up to 250 l/min (66 us gal/min)

1/2" to 1 1/2"
Up to 250 l/min
(66 US gal/min)



PERFORMER

Plastic: DP200
Metal: DP200

Enhanced Leading Technology

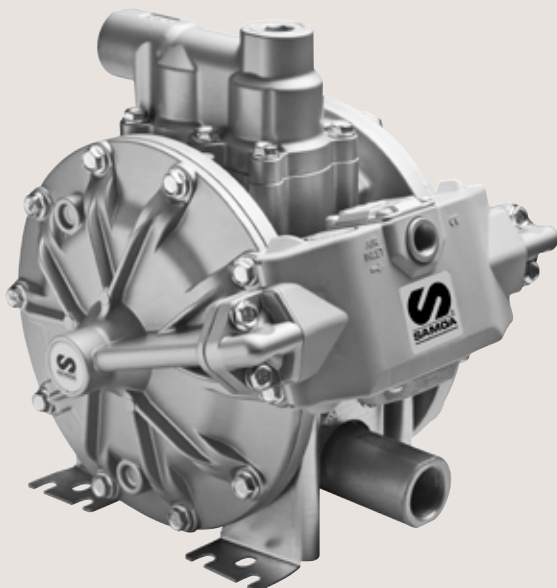

- ▶ Designed for maximum performance and efficiency with high flow rates
- ▶ Improved frictionless pivot valve module
 - Reduced air consumption.
- ▶ Orientable inlet and outlet ports
 - Increased installation versatility.

1"
Up to 200 l/min
(53 US gal/min)

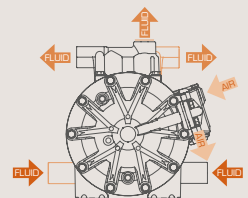

Vertical fluid outlet, only in metal version

DIRECTFLO® PUMP RANGE

PLASTIC PUMPS

Plastic Directflo® pump wetted bodies are compatible with even the most aggressive chemicals, and the plastic directional air valve and air chamber covers are suitable for use in corrosive environments.



	DC20	DC30	DC50	DF30
Pressure ratio	1:1	1:1	1:1	1:1
Maximum free delivery ⁽¹⁾	20 l/min (5 US gal/min)	38 l/min (10 US gal/min)	50 l/min (14 US gal/min)	38 l/min (10 US gal/min)
Delivery per stroke approx. ^{(1) (2)}	0,03 litres (0.008 US gal)	0,07 litres (0.02 US gal)	0,1 litres (0.026 US gal)	0,07 litres (0.02 US gal)
Delivery per cycle (2 x strokes) ^{(1) (2)}	0,06 litres (0.016 US gal)	0,14 litres (0.04 US gal)	0,2 litres (0.05 US gal)	0,14 litres (0.04 US gal)
Air pressure operating range	1,5 to 7 bar (22 to 100 psi)	1,5 to 7 bar (22 to 100 psi)	1,5 to 7 bar (22 to 100 psi)	1,5 to 8 bar (22 to 115 psi)
Solids in suspension max. size	2 mm (3/32")	3 mm (1/8")	3 mm (1/8")	3 mm (1/8")
Maximum dry suction lift ⁽¹⁾	2 m (6 1/2")	4 m (13')	6 m (20')	4 m (13')
Maximum wet suction lift ⁽¹⁾	7 m (23')	8 m (26')	8 m (26')	8 m (26')
Weight	1,2 kg (2,65 lb)	1,9 kg (4.19 lb)	2,2 kg (4.85 lb)	1,9 kg (4.19 lb)
Fluid inlet connection	Int.: 1/4" BSP/NPT (F) Ext.: 3/4" NPT (M)	1/2" BSP/NPT (F)	1/2" BSP/NPT (F)	1/2" BSP/NPT (F)
Fluid outlet connection	Int.: 1/4" BSP/NPT (F) Ext.: 3/4" NPT (M)	1/2" BSP/NPT (F)	1/2" BSP/NPT (F)	1/2" BSP/NPT (F)
Air inlet connection	3/8" NPSM (F)	3/8" NPSM (F)	3/8" NPSM (F)	3/8" NPSM (F)
Wetted part materials	See recommended models on next pages.			

(1) Data measured with water, air inlet pressure 7 bar (100 psi) with DC models (8 bar (115 psi) with DF and DP models), 20 °C (68 °F) and flooded fluid inlet.

(2) Approximate value; real value may vary depending on working conditions, fluid pumped and pump materials.

METAL PUMPS

Metal Directflo® pumps are extremely robust and thanks to a wide range of wetted materials are compatible with many fluids.

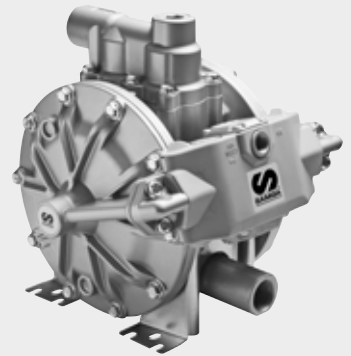

	DF50	DF100	DF250	DP200
Pressure ratio	1:1	1:1	1:1	1:1
Maximum free delivery ⁽¹⁾	50 l/min (14 US gal/min)	100 l/min (28 US gal/min)	250 l/min (66 US gal/min)	200 l/min (53 gal/min)
Delivery per stroke approx. ^{(1) (2)}	0,1 litres (0.026 US gal)	0,25 litres (0.07 US gal)	0,6 litres (0.16 US gal)	0,5 litres (0.13 US gal)
Delivery per cycle (2 x strokes) ^{(1) (2)}	0,2 litres (0.05 US gal)	0,5 litres (0.13 US gal)	1,2 litres (0.32 US gal)	1 litre (0.26 US gal)
Air pressure operating range	1,5 to 8 bar (22 to 115 psi)	1,5 to 8 bar (22 to 115 psi)	1,5 to 8 bar (22 to 115 psi)	1,5 to 8 bar (22 to 115 psi)
Solids in suspension max. size	3 mm (1/8")	4 mm (3/16")	6 mm (1/4")	6 mm (1/4")
Maximum dry suction lift ⁽¹⁾	6 m (20')	4,5 m (15')	5 m (16.4')	5 m (16')
Maximum wet suction lift ⁽¹⁾	8 m (26')	7 m (23')	8 m (26')	8 m (26')
Weight	3,5 kg (7.72 lb)	7,2 kg (16 lb)	20 kg (45 lb)	11,5 kg (23.35 lb)
Fluid inlet connection	1/2" NPSM (F)	1" BSP/NPT (F)	1 1/2" BSP (F) and DIN PN-10 DN40 flange or 1 1/2" NPT (F) and ANSI 1" B16.5 150 lb flange	1" BSP/NPT (F)
Fluid outlet connection	1/2" NPSM (F)	1" BSP/NPT (F)	1 1/2" BSP (F) and DIN PN-10 DN40 flange or 1 1/2" NPT (F) and ANSI 1" B16.5 150 lb flange	1" BSP/NPT (F)
Air inlet connection	3/8" NPSM (F)	3/8" NPSM (F)	1/2" NPSM (F)	3/8" NPSM (F)
Wetted part materials	See recommended models on next pages.			

(1) Data measured with water, air inlet pressure 7 bar (100 psi) with DC models (8 bar (115 psi) with DF and DP models), 20 °C (68 °F) and flooded fluid inlet.

(2) Approximate value; real value may vary depending on working conditions, fluid pumped and pump materials.

PLASTIC PUMPS



DF30T	DF50	DF50T	DF100	DP200
1:1	1:1	1:1	1:1	1:1
38 l/min (10 US gal/min)	50 l/min (14 US gal/min)	50 l/min (14 US gal/min)	100 l/min (28 US gal/min)	200 l/min (53 gal/min)
0,07 litres (0.02 US gal)	0,1 litres (0.026 US gal)	0,1 litres (0.026 US gal)	0,25 litres (0.07 US gal)	0,5 litres (0.13 US gal)
0,14 litres (0.04 US gal)	0,2 litres (0.05 US gal)	0,2 litres (0.05 US gal)	0,50 litres (0.13 US gal)	1 litre (0.26 US gal)
1,5 to 8 bar (22 to 115 psi)	1,5 to 8 bar (22 to 115 psi)	1,5 to 8 bar (22 to 115 psi)	1,5 to 8 bar (22 to 115 psi)	1,5 to 8 bar (22 to 115 psi)
3 mm (1/8")	3 mm (1/8")	3 mm (1/8")	4 mm (3/16")	6 mm (1/4")
4 m (13')	6 m (20')	6 m (20')	4,5 m (15')	5 m (16')
8 m (26')	8 m (26')	8 m (26')	7 m (23')	8 m (26')
1,9 kg (4.19 lb)	2,2 kg (4.85 lb)	2,2 kg (4.85 lb)	5,1 kg (11.24 lb)	10,5 kg (23.15 lb)
2 x 3/8" BSP/NPT (F)	1/2" BSP/NPT (F)	2 x 3/8" BSP/NPT (F)	1" BSP/NPT (F)	1" DIN PN-10 DN25 flange and ANSI B16.5 1" 150 lb flange
1/2" BSP/NPT (F)	1/2" BSP/NPT (F)	1/2" BSP/NPT (F)	1" BSP/NPT (F)	1" DIN PN-10 DN25 flange and ANSI B16.5 1" 150 lb flange
3/8" NPSM (F)	3/8" NPSM (F)	3/8" NPSM (F)	3/8" NPSM (F)	3/8" NPSM (F)

See recommended models on next pages.

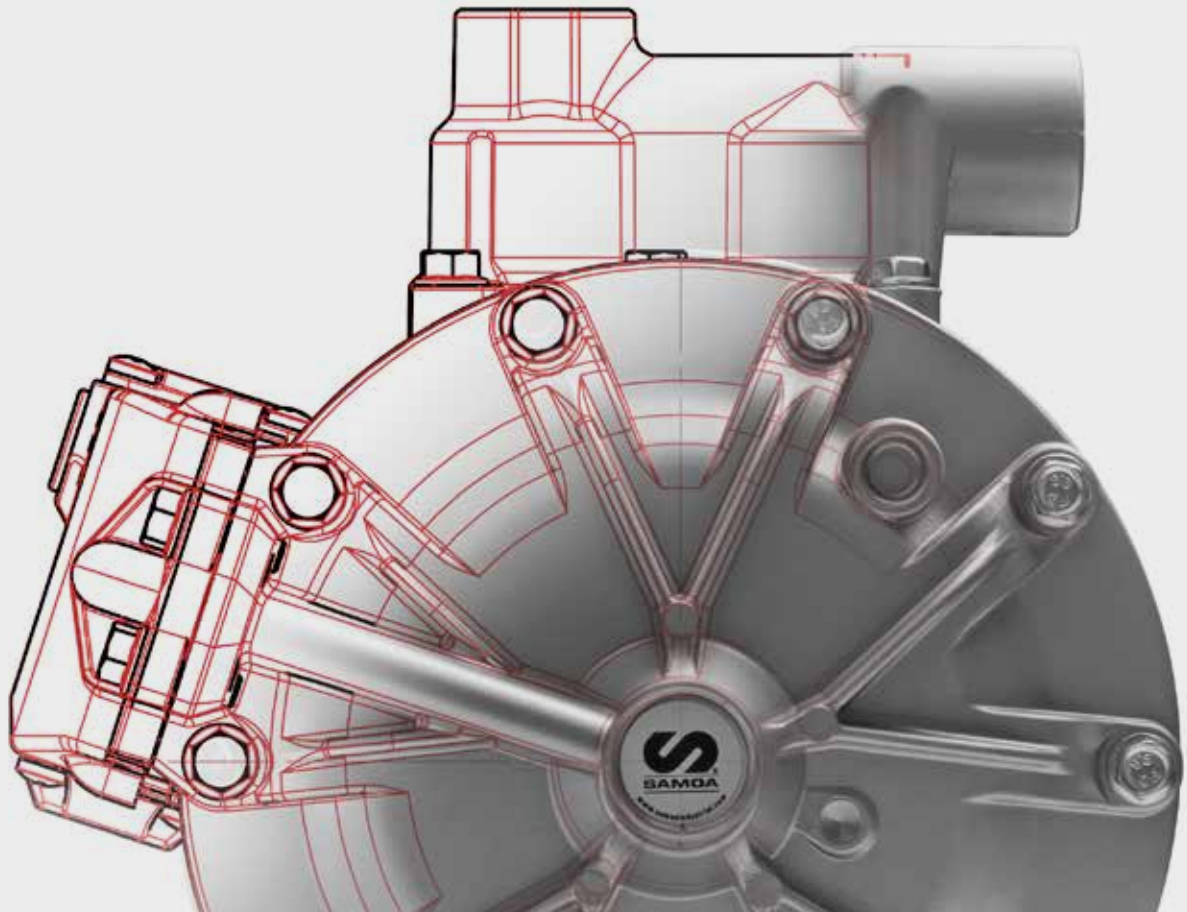

Reliable Compact Design

DC20 PLASTIC PUMPS

Air operated double diaphragm pumps for dosing and transferring a wide variety of fluids.

For OEM applications and industrial processes with lower flow rates. Unbalanced spool valve air motor requires lower start-up pressure for finer flow adjustment using regulating air pressure.

Pump wetted materials are compatible with the most aggressive fluids and are suitable for use in corrosive environments. Air motor (directional air valve and air chamber covers) is made of polypropylene.

Fully groundable ATEX certified pumps are available for use in potentially explosive atmospheres (Ex II2 GD IIB/IIC 95 °C).

1/4"
20 l/min
5 US gal/min

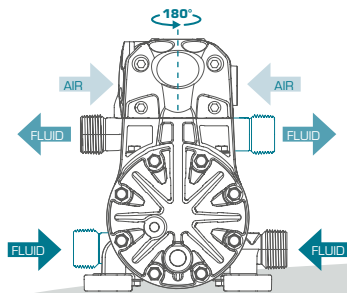

Orientable ports, increased installation flexibility.



Ex ATEX certified versions available
Ex II2 GD IIB/IIC 95 °C

RECOMMENDED MODELS

MODEL	PUMP BODY	DIAPHRAGMS	BALLS	SEATS	OTHER WETTED MATERIALS	RECOMMENDED APPLICATIONS
DC20PPSEPTMBAS	Polypropylene	Santoprene®	PTFE	Polypropylene	Stainless Steel, EPDM	Water based fluids and adhesives, diluted alkalis and acids, alcohols and water based coatings.
DC20PPSVPTHBAS	Polypropylene	TPE	PTFE	Polypropylene	Stainless Steel, FKM	Non aggressive aqueous chemical solutions, water.
DC20PPSTPTTBAS	Polypropylene	PTFE	PTFE	Polypropylene	Stainless Steel	Wide chemical compatibility. Good with acids and alkalis.
DC20PPYPTTBAS	Polypropylene	PTFE	PTFE	Polypropylene	Hastelloy® C	CIPs chlorinated cleaning agents and home industrial cleaning agents. Acids and alkalis.
DC20PWYTWTTBAS	PVDF	PTFE	PTFE	PVDF	Hastelloy® C	Almost universal chemical pump, including strong acids and alkalis above room temperature. Not recommended for some strong alkalis or concentrated nitric acid.
DC20PDSTCTTBAS	Conductive Acetal	PTFE	PTFE	Acetal	Stainless Steel	ATEX pump. Solvents (most ketones, acetates, aldehydes, aromatic and chlorinated hydrocarbons), solvent and water based flexo and gravure inks, varnishes and paint.



DC20 PLASTIC PUMPS

TECHNICAL DATA

Pressure ratio	1:1
Maximum free delivery (1)	20 l/min (5 US gal/min)
Delivery per stroke approx. (1)	0,03 litres (0.008 US gal)
Delivery per cycle (2 x strokes) (1)	0,06 litres (0.016 US gal)
Air pressure operating range	1,5 to 7 bar (22 to 100 psi)
Solids in suspension max. size	2 mm (3/32")
Maximum dry suction lift (1)	2 m (6 1/2')
Maximum wet suction lift (1)	7 m (23')
Weight	1,2 kg (2.65 lb)
Fluid inlet connection	Int.: 1/4" BSP/NPT (F) / Ext.: 3/4" NPT (M)
Fluid outlet connection	Int.: 1/4" BSP/NPT (F) / Ext.: 3/4" NPT (M)
Air inlet connection	3/8" NPSM (F)
Wetted part materials	See recommended models

(1) Data measured with water, air inlet pressure 7 bar (100 psi), 20 °C (68 °F).

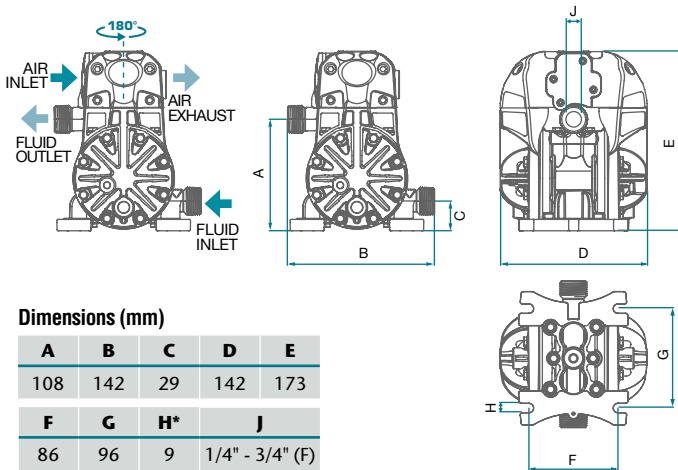

Dimensions (mm)

A	B	C	D	E
108	142	29	142	173
F	G	H*	J	
86	96	9	1/4" - 3/4" (F)	

* Diameter of the holes for fasteners in each of the four pump feet.
Flange connection: 2 bolts - M 5 (41 mm between centres).

PERFORMANCE CURVES

Tested at room temperature, with water and flooded pump with 800 mm (31 1/2") height of water above the pump inlet.

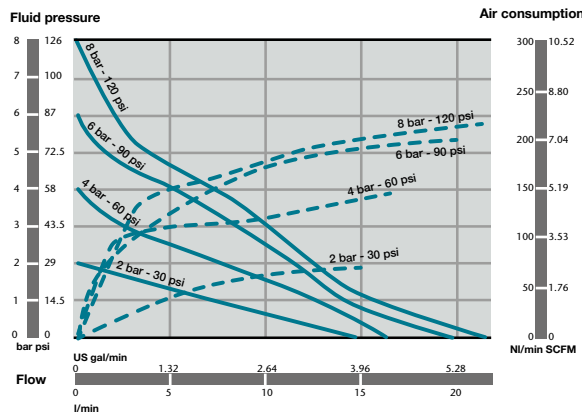

— Outlet pressure
- - - Air consumption

DC20 PLASTIC PUMP CODING SYSTEM

1	2	3	4	5	6	7	8	9	10
DC20	P	P	S	E	P	T	M	B	AS

1 PUMP SIZE

DC20

2 AIR MOTOR: DIRECTIONAL VALVE & AIR CHAMBER COVERS

P = Polypropylene

3 WETTED PUMP BODY

P = Polypropylene

B = Conductive Polypropylene (ATEX pump)

D = Conductive Acetal (ATEX pump)

W = PVDF

K = Conductive PVDF

4 PUSH ROD

S = Stainless Steel AISI 420

Y = Hastelloy® C

5 SEALS

V = FKM (Viton®)

E = EPDM

T = PTFE (Teflon®)

6 CHECK VALVE SEATS

P = Polypropylene

C = Acetal

W = PVDF

7 CHECK VALVE BALLS

T = PTFE (Teflon®)

C = Acetal

8 DIAPHRAGMS

T = PTFE (Teflon®)

M = Santoprene®

H = TPE (Hytrel®)

9 FLUID CONNECTION THREADS

B = BSP

N = NPT

10 OPTIONS

AS = Standard pump

BS = Remote air exhaust *

DS = Stroke sensor

FS = Extra muffler

* Included in all DC20 pumps

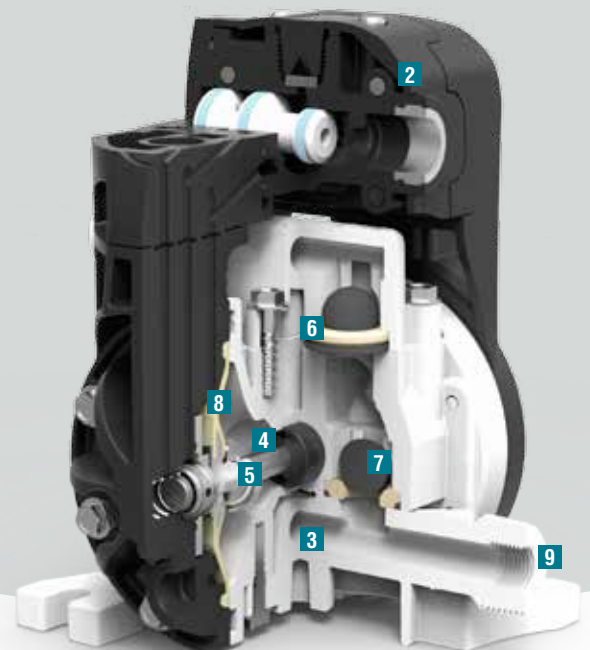

Reliable Compact Design

DC30 PLASTIC PUMPS

Air operated double diaphragm pumps for dosing and transferring a wide variety of fluids.

For OEM applications and industrial processes with lower flow rates. Unbalanced spool valve air motor requires lower start-up pressure for finer flow adjustment using regulating air pressure.

Pump wetted materials are compatible with the most aggressive fluids and are suitable for use in corrosive environments. Air motor (directional air valve and air chamber covers) is made of polypropylene.

Fully groundable ATEX certified pumps are available for use in potentially explosive atmospheres (Ex II2 GD IIB/IIC 95 °C).

1/2"
38 l/min
10 US gal/min

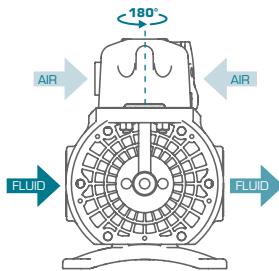

Orientable air inlet, increased installation flexibility.



Ex ATEX certified versions available
Ex II2 GD IIB/IIC 95 °C

RECOMMENDED MODELS

MODEL	PUMP BODY	DIAPHRAGMS	BALLS	SEATS	OTHER WETTED MATERIALS	RECOMMENDED APPLICATIONS
DC30PPSESTMBAS	Polypropylene	Santoprene®	PTFE	Stainless Steel	EPDM	Water based fluids and adhesives, diluted alkalis and acids, alcohols and water based coatings.
DC30PPSTSTTBAS	Polypropylene	PTFE	PTFE	Stainless Steel	Stainless Steel	Wide chemical compatibility. Good with acids and alkalis.
DC30PPYTWTTBAS	Polypropylene	PTFE	PTFE	PVDF	Hastelloy® C	CIPs chlorinated cleaning agents and home & industrial cleaning agents. Acids and alkalis.
DC30PDSTSTTBAS	Conductive Acetal	PTFE	PTFE	Stainless Steel	Stainless Steel	ATEX pump. Solvents (most ketones, acetates, aldehydes, aromatic and chlorinated hydrocarbons), solvent and water based flexo and gravure inks, varnishes and paint.



DC30 PLASTIC PUMPS

TECHNICAL DATA

Pressure ratio	1:1
Maximum free delivery (1)	38 l/min (10 US gal/min)
Delivery per stroke approx. (1)	0,07 litres (0.02 US gal)
Delivery per cycle (2 x strokes) (1)	0,14 litres (0.04 US gal)
Air pressure operating range	1,5 to 7 bar (22 to 100 psi)
Solids in suspension max. size	3 mm (1/8")
Maximum dry suction lift (1)	4 m (13')
Maximum wet suction lift (1)	8 m (26')
Weight	1,9 kg (4.19 lb)
Fluid inlet connection	1/2" BSP/NPT (F)
Fluid outlet connection	1/2" BSP/NPT (F)
Air inlet connection	3/8" NPSM (F)
Wetted part materials	See recommended models

(1) Data measured with water, air inlet pressure 7 bar (100 psi), 20 °C (68 °F).

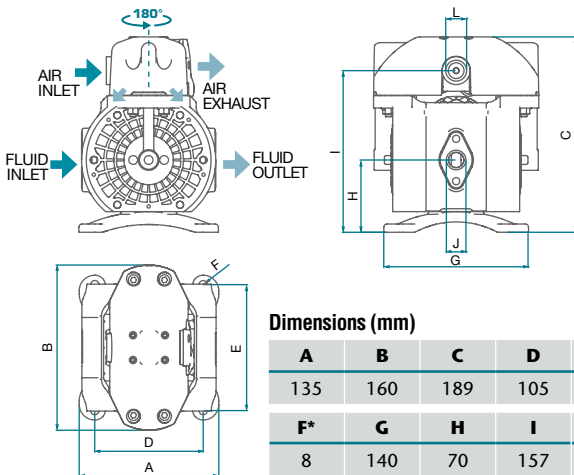

Dimensions (mm)

A	B	C	D	E	
135	160	189	105	122	
F*	G	H	I	J	L
8	140	70	157	1/2" (F)	3/8" (F)

* Diameter of the holes for fasteners in each of the four pump feet.

PERFORMANCE CURVES

Tested at room temperature, with water and flooded pump with 800 mm (31 1/2") height of water above the pump inlet.

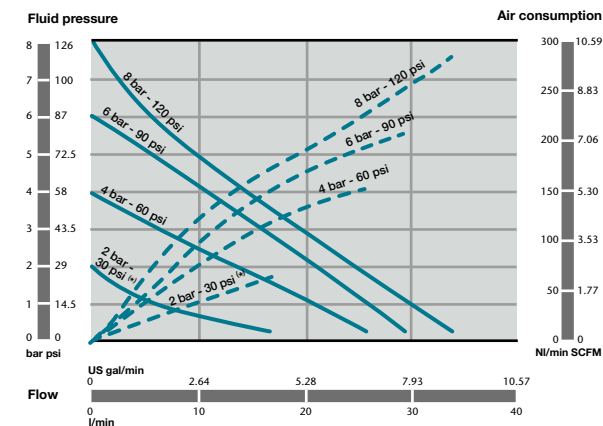

— Outlet pressure
- - - Air consumption

(*) 2 bar test with a PTFE (Teflon®) diaphragms pump.

DC30 PLASTIC PUMP CODING SYSTEM

1	2	3	4	5	6	7	8	9	10
DC30	P	P	S	E	S	T	M	B	AS

1 PUMP SIZE

DC30

2 AIR MOTOR: DIRECTIONAL VALVE & AIR CHAMBER COVERS

P = Polypropylene

3 WETTED PUMP BODY

P = Polypropylene

D = Conductive Acetal (ATEX pump)

4 PUSH ROD

S = Stainless Steel AISI 420

Y = Hastelloy® C

5 SEALS

E = EPDM

T = PTFE (Teflon®)

6 CHECK VALVE SEATS

S = Stainless Steel AISI 316

W = PVDF

7 CHECK VALVE BALLS

T = PTFE (Teflon®)

C = Acetal

8 DIAPHRAGMS

T = PTFE (Teflon®)

M = Santoprene®

9 FLUID CONNECTION THREADS

B = BSP

N = NPT

10 OPTIONS

AS = Standard pump

BS = Remote air exhaust

FS = Extra muffler

US = Special UV Ink pump

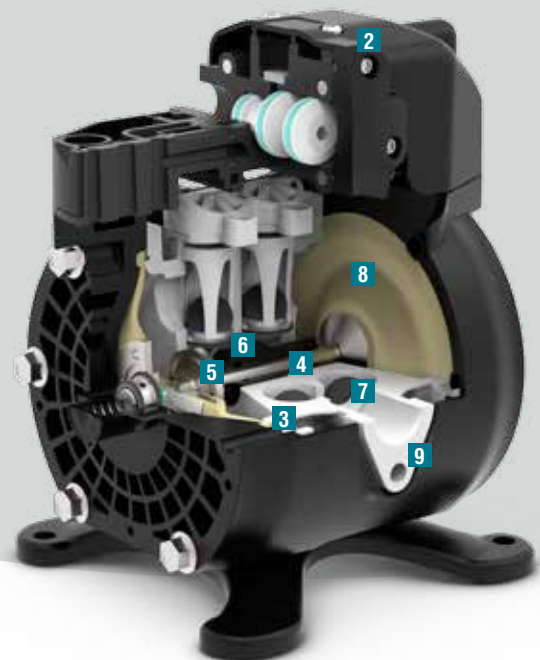

Reliable Compact Design

DC50 PLASTIC PUMPS

Air operated double diaphragm pumps for dosing and transferring a wide variety of fluids.

For OEM applications and industrial processes with lower flow rates. Unbalanced spool valve air motor requires lower start-up pressure for finer flow adjustment using regulating air pressure.

Pump wetted materials are compatible with the most aggressive fluids and are suitable for use in corrosive environments. Air motor (directional air valve and air chamber covers) is made of polypropylene.

Fully groundable ATEX certified pumps are available for use in potentially explosive atmospheres (Ex II2 GD IIB/IIC 95 °C).

1/2"
50 l/min
14 US gal/min

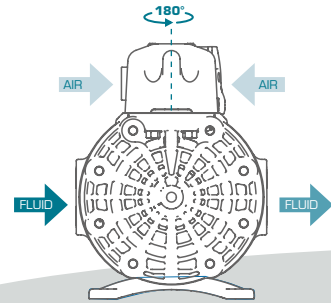

Orientable air inlet, increased installation flexibility.



Ex ATEX certified versions available
Ex II2 GD IIB/IIC 95 °C

RECOMMENDED MODELS

MODEL	PUMP BODY	DIAPHRAGMS	BALLS	SEATS	OTHER WETTED MATERIALS	RECOMMENDED APPLICATIONS
DC50PPSESTMBAS	Polypropylene	Santoprene®	PTFE	Stainless Steel	EPDM	Water based fluids and adhesives, diluted alkalis and acids, alcohols and water based coatings.
DC50PPSTSTTBAS	Polypropylene	PTFE	PTFE	Stainless Steel	Stainless Steel	Wide chemical compatibility. Good with acids and alkalis.
DC50PPYTWTBAS	Polypropylene	PTFE	PTFE	PVDF	Hastelloy® C	CIPs chlorinated cleaning agents and home & industrial cleaning agents. Acids and alkalis.
DC50PDSTSTTBAS	Conductive Acetal	PTFE	PTFE	Stainless Steel	Stainless Steel	ATEX pump. Solvents (most ketones, acetates, aldehydes, aromatic and chlorinated hydrocarbons), solvent and water based flexo and gravure inks, varnishes and paint.



DC50 PLASTIC PUMPS

TECHNICAL DATA

Pressure ratio	1:1
Maximum free delivery (1)	50 l/min (14 US gal/min)
Delivery per stroke approx. (1)	0,1 litres (0.026 US gal)
Delivery per cycle (2 x strokes) (1)	0,2 litres (0.05 US gal)
Air pressure operating range	1,5 to 7 bar (22 to 100 psi)
Solids in suspension max. size	3 mm (1/8")
Maximum dry suction lift (1)	6 m (20')
Maximum wet suction lift (1)	8 m (26')
Weight	2,2 kg (4.85 lb)
Fluid inlet connection	1/2" BSP/NPT (F)
Fluid outlet connection	1/2" BSP/NPT (F)
Air inlet connection	3/8" NPSM (F)
Wetted part materials	See recommended models

(1) Data measured with water, air inlet pressure 7 bar (100 psi), 20 °C (68 °F).

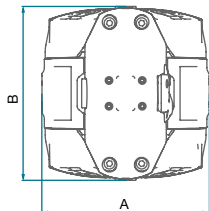
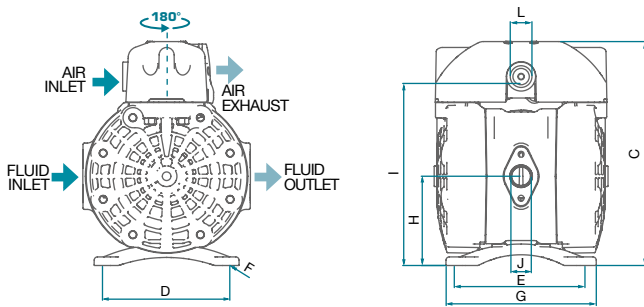

Dimensions (mm)

A	B	C	D	E	
156	162	209	105	122	
F*	G	H	I	J	L
8	140	83	176	1/2" (F)	3/8" (F)

* Diameter of the holes for fasteners in each of the four pump feet.

PERFORMANCE CURVES

Tested at room temperature, with water and flooded pump with 800 mm (31 1/2") height of water above the pump inlet.

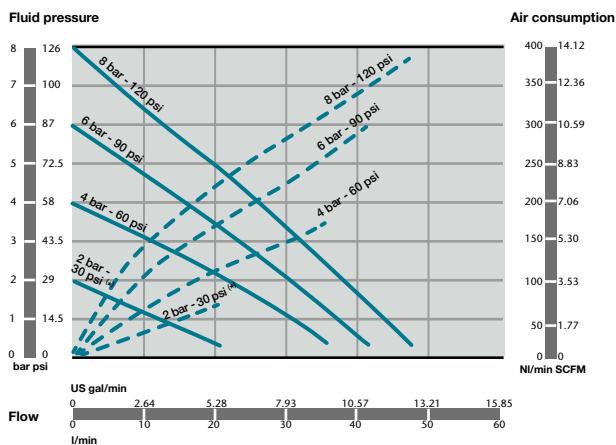

— Outlet pressure
- - - Air consumption

(*) 2 bar test with a PTFE (Teflon®) diaphragms pump.

DC50 PLASTIC PUMP CODING SYSTEM

1	2	3	4	5	6	7	8	9	10
DC50	P	P	S	E	S	T	M	B	AS

1 PUMP SIZE

DC50

2 AIR MOTOR: DIRECTIONAL VALVE & AIR CHAMBER COVERS

P = Polypropylene

3 WETTED PUMP BODY

P = Polypropylene

D = Conductive Acetal (ATEX pump)

4 PUSH ROD

S = Stainless Steel AISI 420

Y = Hastelloy® C

5 SEALS

E = EPDM

T = PTFE (Teflon®)

6 CHECK VALVE SEATS

S = Stainless Steel AISI 316

W = PVDF

7 CHECK VALVE BALLS

T = PTFE (Teflon®)

C = Acetal

8 DIAPHRAGMS

T = PTFE (Teflon®)

M = Santoprene®

9 FLUID CONNECTION THREADS

B = BSP

N = NPT

10 OPTIONS

AS = Standard pump

BS = Remote air exhaust

FS = Extra muffler

US = Special UV Ink pump

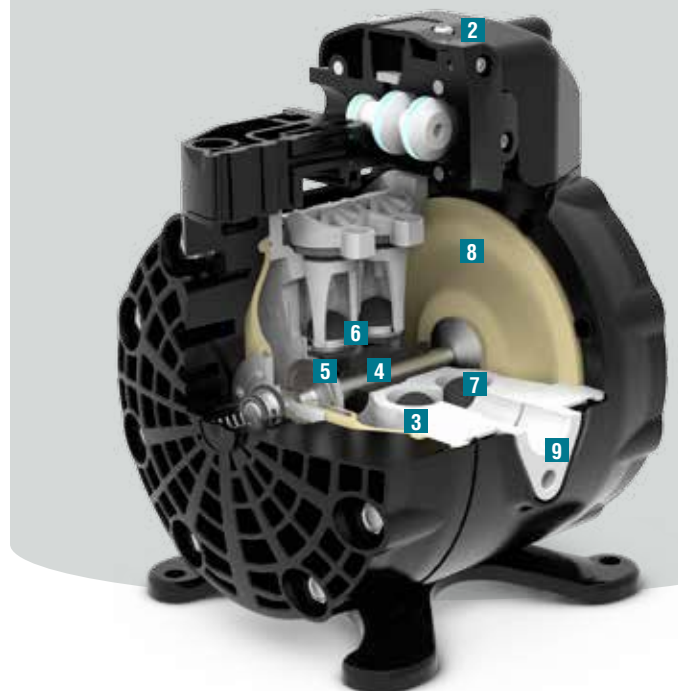

Original Directflo® Technology

DF30 & DF30T PLASTIC PUMPS

Air operated double diaphragm pumps for dosing, spraying, transferring and distributing a wide variety of fluids in small flow rates applications.

Pump wetted parts are compatible even with the most aggressive fluids and are suitable for use in corrosive environments. Air motor (directional air valve and air chamber covers) is made of polypropylene.

DF30T are dual inlet pumps for 1:1 ratio mixing of fluids with similar viscosity. Both, the initial fluids and the resulting mixture, must be compatible with the pump's wetted materials.

Fully groundable ATEX certified pumps are available for use in potentially explosive atmospheres (Ex II2 GD IIB/IIC 95 °C).

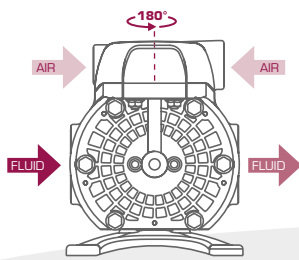

Orientable air inlet, increased installation flexibility.

1/2"
38 l/min
10 US gal/min



Ex ATEX certified versions available
Ex II2 GD IIB/IIC 95 °C

RECOMMENDED MODELS

MODEL	PUMP BODY	DIAPHRAGMS	BALLS	SEATS	OTHER WETTED MATERIALS	RECOMMENDED APPLICATIONS
DF30PPSESTMBAS	Polypropylene	Santoprene®	PTFE	Stainless Steel	EPDM	Water based fluids, coatings and adhesives, diluted mild alkalis and acids, alcohols.
DF30PPSVSTHBAS	Polypropylene	TPE	PTFE	Stainless Steel	FKM	Water and some aqueous chemicals. General application pump for lubricants.
DF30PPYTWTBAS	Polypropylene	PTFE	PTFE	PVDF	Hastelloy® C	Wide compatibility, including acids and alkalis for water treatment and CIPs chlorinated cleaning agents for home & industrial cleaning processes.
DF30PPSTSTTBAS	Polypropylene	PTFE	PTFE	Stainless Steel	-	Wide chemical compatibility.
DF30PKYTWTBAS	Conductive PVDF	PTFE	PTFE	PVDF	Hastelloy® C	ATEX pump. Strong acids (some above room temperature) and alkalis. Not recommended for some strong alkalis or concentrated nitric acid. Ex
DF30PDSTSTTBAS	Conductive Acetal	PTFE	PTFE	Stainless Steel	-	ATEX pump. Solvents (most ketones, acetates, aldehydes, aromatic and chlorinated hydrocarbons, toluene) and solvents based inks, paints and varnishes. Ex

DF30 & DF30T PLASTIC PUMPS

TECHNICAL DATA

Pressure ratio	1:1
Maximum free delivery (1)	38 l/min (10 US gal/min)
Delivery per stroke approx. (1)	0,07 litres (0.02 US gal)
Delivery per cycle (2 x strokes) (1)	0,14 litres (0.04 US gal)
Air pressure operating range	1,5 to 8 bar (22 to 115 psi)
Solids in suspension max. size	3 mm (1/8")
Maximum dry suction lift (1)	4 m (13')
Maximum wet suction lift (1)	8 m (26')
Weight	1,9 kg (4.19 lb)
Fluid inlet connection	1/2" BSP/NPT (F) 2 x 3/8" BSP/NPT (F) (DF30T)
Fluid outlet connection	1/2" BSP/NPT (F)
Air inlet connection	3/8" NPSM (F)
Wetted part materials	See recommended models

(1) Data measured with water, air inlet pressure 7 bar (100 psi), 20 °C (68 °F).

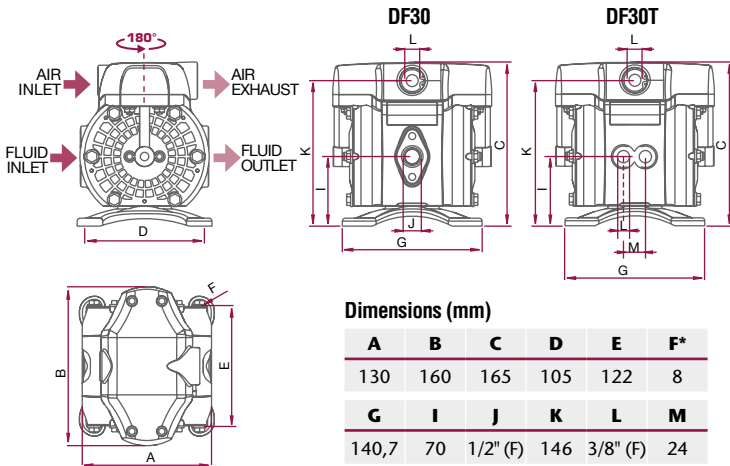

Dimensions (mm)

A	B	C	D	E	F*
130	160	165	105	122	8
G	I	J	K	L	M
140,7	70	1/2" (F)	146	3/8" (F)	24

* Diameter of the holes for fasteners in each of the four pump feet.

PERFORMANCE CURVES

Tested at room temperature, with water and flooded pump with 800 mm (31 1/2") height of water above the pump inlet.

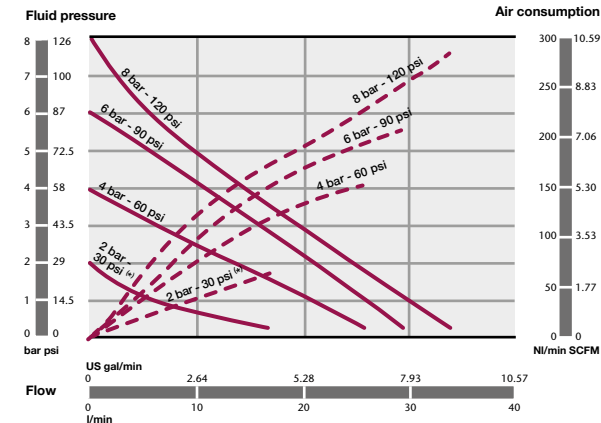

— Outlet pressure
- - - Air consumption

(*) 2 bar test with a PTFE (Teflon®) diaphragms pump.

DF30 & DF30T PLASTIC PUMP CODING SYSTEM

1	2	3	4	5	6	7	8	9	10
DF30	P	P	S	E	S	T	M	B	AS

1 PUMP SIZE

DF30
DF30T (Dual inlet)

2 AIR MOTOR: DIRECTIONAL VALVE & AIR CHAMBER COVERS

P = Polypropylene

3 WETTED PUMP BODY

P = Polypropylene
B = Conductive Polypropylene (ATEX pump)
D = Conductive Acetal (ATEX pump)
W = PVDF *
K = Conductive PVDF (ATEX pump) *

4 PUSH ROD

S = Stainless Steel AISI 420
Y = Hastelloy® C *

5 SEALS

V = FKM (Viton®)
E = EPDM
T = PTFE (Teflon®)

6 CHECK VALVE SEATS

S = Stainless Steel AISI 316
W = PVDF *

7 CHECK VALVE BALLS

T = PTFE (Teflon®)
C = Acetal
S = Stainless Steel AISI 316

8 DIAPHRAGMS

T = PTFE (Teflon®)
M = Santoprene®
H = TPE (Hytrel®)

9 FLUID CONNECTION THREADS

B = BSP
N = NPT

10 OPTIONS

AS = Standard pump
BS = Remote air exhaust
ES = Externally driven
FS = Extra muffler
US = Special UV Ink pump
GS = NPN inductive external pump control sensor
IS = ATEX inductive external pump control sensor
JS = PNP inductive external pump control sensor

(*) Not for DF30T pumps

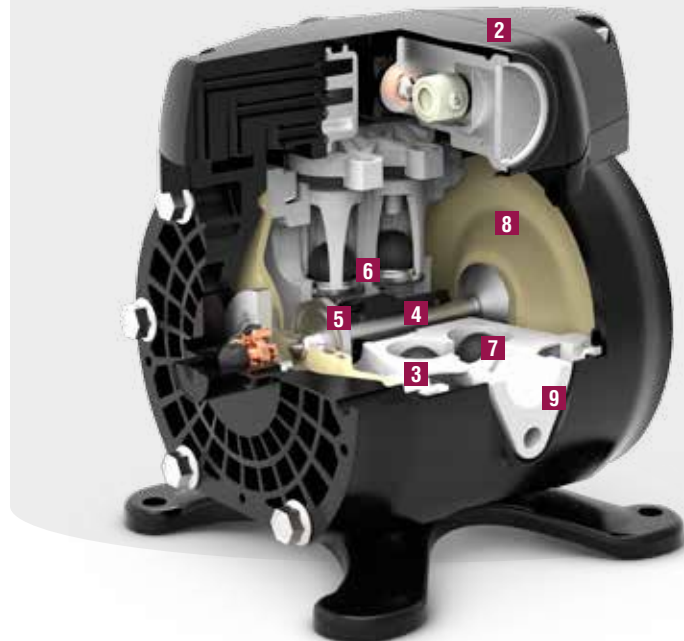

Original Directflo® Technology

DF50 & DF50T PLASTIC PUMPS

Air operated double diaphragm pumps for dosing, spraying, transferring and distributing a wide variety of fluids in small to medium flow rates applications.

Pump wetted parts are compatible even with the most aggressive fluids and are suitable for use in corrosive environments. Air motor (directional air valve and air chamber covers) is made of polypropylene.

DF50T are dual inlet pumps for 1:1 ratio mixing of fluids with similar viscosity. Both, the initial fluids and the resulting mixture, must be compatible with the pump's wetted materials.

Fully groundable ATEX certified pumps are available for use in potentially explosive atmospheres (Ex II2 GD IIB/IIC 95 °C).

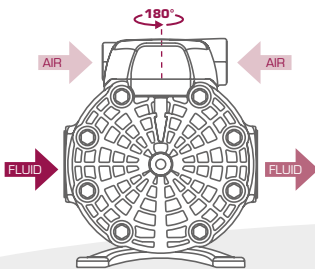



Orientable air inlet, increased installation flexibility.

1/2"
50 l/min
14 US gal/min



Ex ATEX certified versions available
Ex II2 GD IIB/IIC 95 °C

RECOMMENDED MODELS

MODEL	PUMP BODY	DIAPHRAGMS	BALLS	SEATS	OTHER WETTED MATERIALS	RECOMMENDED APPLICATIONS
DF50PPSESTMBAS	Polypropylene	Santoprene®	PTFE	Stainless Steel	EPDM	Water based fluids, coatings and adhesives, diluted mild alkalis and acids, alcohols.
DF50PPSVSTHBAS	Polypropylene	TPE	PTFE	Stainless Steel	FKM	Water and some aqueous chemicals. General application pump for lubricants.
DF50PPYTWTBAS	Polypropylene	PTFE	PTFE	PVDF	Hastelloy® C	Wide compatibility, including acids and alkalis for water treatment and CIPs chlorinated cleaning agents for home & industrial cleaning processes.
DF50PPSTSTTBAS	Polypropylene	PTFE	PTFE	Stainless Steel	-	Wide chemical compatibility.
DF50PKYTWTBAS	Conductive PVDF	PTFE	PTFE	PVDF	Hastelloy® C	ATEX pump. Strong acids (some above room temperature) and alkalis. Not recommended for some strong alkalis or concentrated nitric acid. 
DF50PDSTSTTBAS	Conductive Acetal	PTFE	PTFE	Stainless Steel	-	ATEX pump. Solvents (ketones, acetates, aldehydes, aromatic and chlorinated hydrocarbons, toluene) and solvent based inks, paints and varnishes. 

DF50 & DF50T PLASTIC PUMPS

TECHNICAL DATA

Pressure ratio	1:1
Maximum free delivery (1)	50 l/min (14 US gal/min)
Delivery per stroke approx. (1)	0,1 litres (0.026 US gal)
Delivery per cycle (2 x strokes) (1)	0,2 litres (0.05 US gal)
Air pressure operating range	1,5 to 8 bar (22 to 115 psi)
Solids in suspension max. size	3 mm (1/8")
Maximum dry suction lift (1)	6 m (20')
Maximum wet suction lift (1)	8 m (26')
Weight	2,2 kg (4.85 lb)
Fluid inlet connection	1/2" BSP/NPT (F) - 2 x 3/8" BSP/NPT DF50T
Fluid outlet connection	1/2" BSP/NPT (F)
Air inlet connection	3/8" NPSM (F)
Wetted part materials	See recommended models

(1) Data measured with water, air inlet pressure 7 bar (100 psi), 20 °C (68 °F).

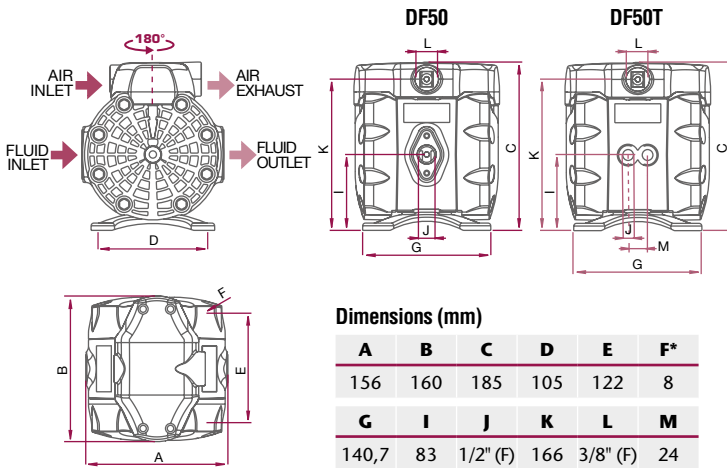

* Diameter of the holes for fasteners in each of the four pump feet.

PERFORMANCE CURVES

Tested at room temperature, with water and flooded pump with 800 mm (31 1/2") height of water above the pump inlet.

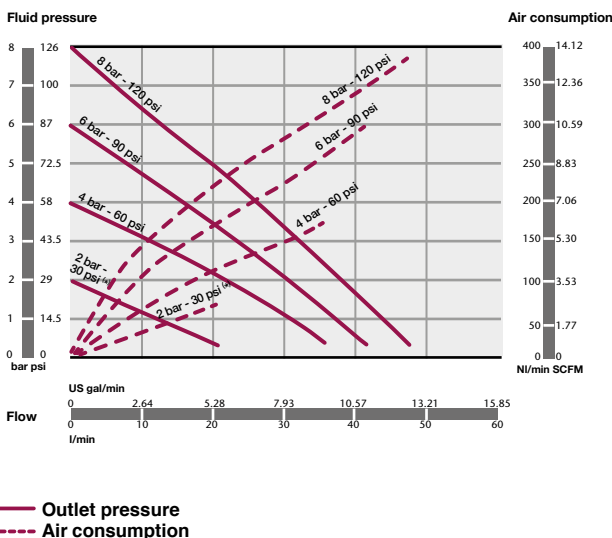

(*) 2 bar test with a pump fitted with PTFE (Teflon®) diaphragms.

DF50 & DF50T PLASTIC PUMP CODING SYSTEM

1	2	3	4	5	6	7	8	9	10
DF50	P	P	S	E	S	T	M	B	AS

1 PUMP SIZE

DF50
DF50T (Dual inlet)

2 AIR MOTOR: DIRECTIONAL VALVE & AIR CHAMBER COVERS

P = Polypropylene

3 WETTED PUMP BODY

P = Polypropylene
 B = Conductive Polypropylene (ATEX pump)
 D = Conductive Acetal (ATEX pump)
 W = PVDF *
 K = Conductive PVDF (ATEX pump) *

4 PUSH ROD

S = Stainless Steel AISI 420
 Y = Hastelloy® C *

5 SEALS

V = FKM (Viton®)
 E = EPDM
 T = PTFE (Teflon®)

6 CHECK VALVE SEATS

S = Stainless Steel AISI 316
 W = PVDF *

7 CHECK VALVE BALLS

T = PTFE (Teflon®)
 C = Acetal
 S = Stainless Steel AISI 316

8 DIAPHRAGMS

T = PTFE (Teflon®)
 M = Santoprene®
 H = TPE (Hytrell®)

9 FLUID CONNECTION THREADS

B = BSP
 N = NPT

10 OPTIONS

AS = Standard pump
 BS = Remote air exhaust
 ES = Externally driven
 FS = Extra muffler
 GS = NPN inductive external pump control sensor
 IS = ATEX inductive external pump control sensor
 JS = PNP inductive external pump control sensor
 US = Special UV ink pump

(*) Not for DF50T pumps

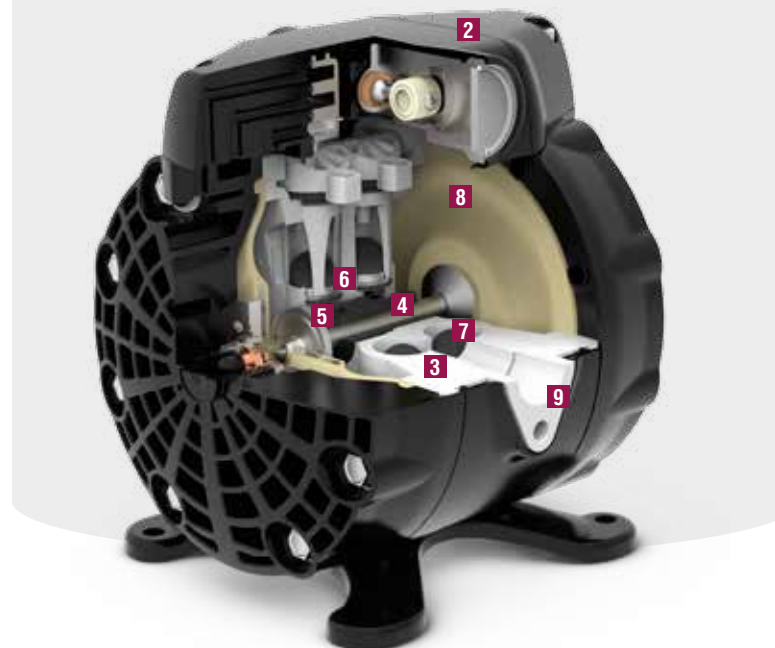

Original Directflo® Technology

DF100 PLASTIC PUMPS

Air operated double diaphragm pumps for dosing, spraying, transferring, evacuating and distributing a wide variety of fluids.

Ideal for standard applications with medium flow rates.

Pump wetted parts are compatible even with the most aggressive fluids and are suitable for use in corrosive environments. Air motor (directional air valve and air chamber covers) is made of polypropylene.

Fully groundable ATEX certified pumps are available for use in potentially explosive atmospheres (Ex II2 GD IIB/IIC 95 °C).

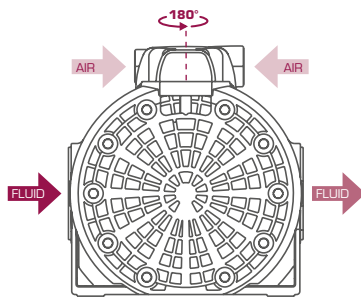



Orientable air inlet, increased installation flexibility.

1"
100 l/min
28 US gal/min



Ex ATEX certified versions available
Ex II2 GD IIB/IIC 95 °C

RECOMMENDED MODELS

MODEL	PUMP BODY	DIAPHRAGMS	BALLS	SEATS	OTHER WETTED MATERIALS	RECOMMENDED APPLICATIONS
DF100PPSESTMBAS	Polypropylene	Santoprene®	PTFE	Stainless Steel	EPDM	Water based fluids, coatings and adhesives, diluted mild alkalis and acids, alcohols.
DF100PPSVSTHBAS	Polypropylene	TPE	PTFE	Stainless Steel	FKM	Water and some aqueous chemicals. General application pump for lubricants.
DF100PPYTWTBAS	Polypropylene	PTFE	PTFE	PVDF	Hastelloy® C	Wide compatibility, including acids and alkalis for water treatment and CIPs chlorinated cleaning agents for home & industrial cleaning processes.
DF100PPSTSTBAS	Polypropylene	PTFE	PTFE	Stainless Steel	-	Wide chemical compatibility.
DF100PKYTWTBAS	Conductive PVDF	PTFE	PTFE	PVDF	Hastelloy® C	ATEX pump. Strong acids (some above room temperature) and alkalis. Not recommended for some strong alkalis or concentrated nitric acid. 
DF100PDSTSTBAS	Conductive Acetal	PTFE	PTFE	Stainless Steel	-	ATEX pump. Solvents (ketones, acetates, aldehydes, aromatic and chlorinated hydrocarbons, toluene) and solvent based inks, paints and varnishes. 

DF100 PLASTIC PUMPS

TECHNICAL DATA

Pressure ratio	1:1
Maximum free delivery (1)	100 l/min (28 US gal/min)
Delivery per stroke approx. (1)	0,25 litres (0.07 US gal)
Delivery per cycle (2 x strokes) (1)	0,5 litres (0.13 US gal)
Air pressure operating range	1,5 to 8 bar (22 to 115 psi)
Solids in suspension max. size	4 mm (3/16")
Maximum dry suction lift (1)	4,5 m (15')
Maximum wet suction lift (1)	7 m (23')
Weight	5,1 kg (11.24 lb)
Fluid inlet connection	1" BSP/NPT (F)
Fluid outlet connection	1" BSP/NPT (F)
Air inlet connection	3/8" NPSM (F)
Wetted part materials	See recommended models

(1) Data measured with water, air inlet pressure 7 bar (100 psi), 20 °C (68 °F).

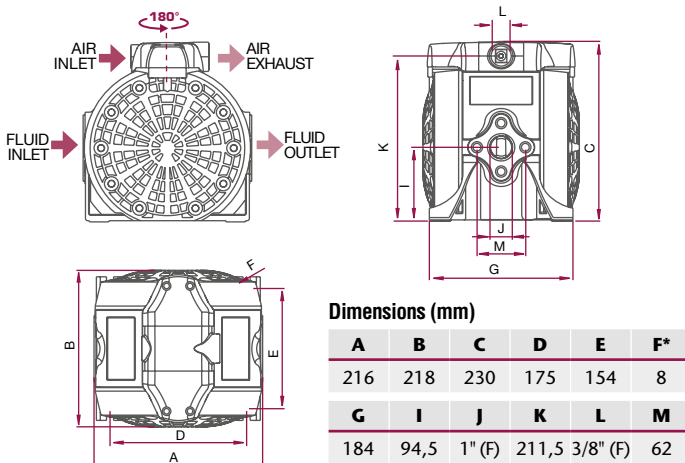

* Diameter of the holes for fasteners in each of the four pump feet.

PERFORMANCE CURVES

Tested at room temperature, with water and flooded pump with 800 mm (31 1/2") height of water above the pump inlet.

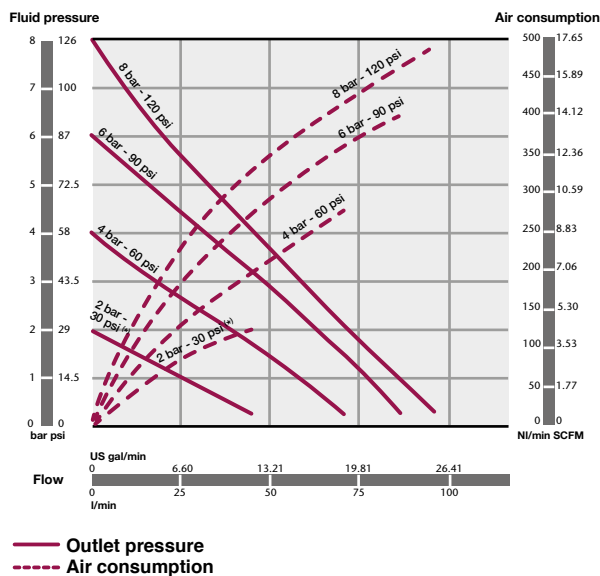

(*) 2 bar test with a pump fitted with PTFE (Teflon®) diaphragms.

DF100 PLASTIC PUMP CODING SYSTEM

1	2	3	4	5	6	7	8	9	10
DF100	P	P	S	E	S	T	M	B	AS

1 PUMP SIZE

DF100

2 AIR MOTOR: DIRECTIONAL VALVE & AIR CHAMBER COVERS

P = Polypropylene

3 WETTED PUMP BODY

P = Polypropylene

B = Conductive Polypropylene

(ATEX pump)

D = Conductive Acetal (ATEX pump)

W = PVDF

K = Conductive PVDF (ATEX pump)

7 CHECK VALVE BALLS

T = PTFE (Teflon®)

C = Acetal

S = Stainless Steel AISI 316

8 DIAPHRAGMS

T = PTFE (Teflon®)

M = Santoprene®

H = TPE (Hytrel®)

9 FLUID CONNECTION THREADS

B = BSP

N = NPT

10 OPTIONS

AS = Standard pump

BS = Remote air exhaust

ES = Externally driven

FS = Extra muffler

GS = NPN inductive external pump control sensor

IS = ATEX inductive external pump control sensor

JS = PNP inductive external pump control sensor

US = Special UV ink pump

6 CHECK VALVE SEATS

S = Stainless Steel AISI 316

W = PVDF

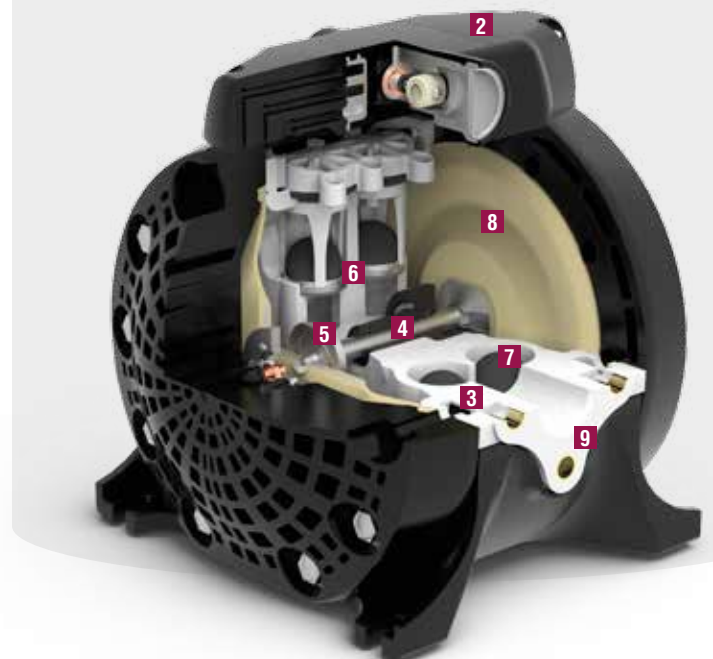

Enhanced Leading Technology

DP200 PLASTIC PUMPS

Air operated double diaphragm pumps for dosing, spraying, transferring, evacuating and distributing a wide variety of fluids.

Designed for maximum performance and efficiency in high flow applications.

Plastic pumps are recommended for some submersible applications and aggressive atmospheres.

Fully groundable ATEX certified pumps are available for use in potentially explosive atmospheres (Ex II2 GD IIB/IC 95 °C).

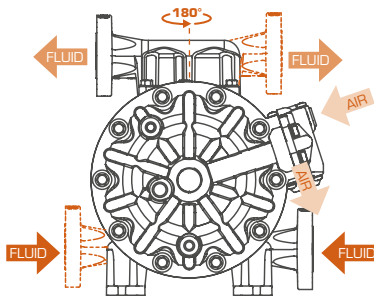

Orientable ports, increased installation versatility.



RECOMMENDED MODELS

MODEL	PUMP BODY	DIAPHRAGMS	BALLS	SEATS	OTHER WETTED MATERIALS	RECOMMENDED APPLICATIONS
DP200PPSEMTMFAS	Polypropylene	Santoprene®	PTFE	Santoprene®	EPDM	Water based fluids, coatings and adhesives, diluted mild alkalis and acids, alcohols.
DP200PPSVHTHFAS	Polypropylene	TPE	PTFE	TPE	FKM	Water and some aqueous chemicals. General application pump for lubricants.
DP200PPYTPTTFAS	Polypropylene	PTFE	PTFE	Polypropylene	Hastelloy® C	Wide compatibility, including acids and alkalis for water treatment and CIPs chlorinated cleaning agents for home & industrial cleaning processes.
DP200PPSTPTTFAS	Polypropylene	PTFE	PTFE	Polypropylene	-	Wide chemical compatibility.
DP200PKYTWTFAS	Conductive PVDF	PTFE	PTFE	PVDF	Hastelloy® C	ATEX pump. Strong acids (some above room temperature) and alkalis. Not recommended for some strong alkalis or concentrated nitric acid.
DP200PDSTCTTFAS	Conductive Acetal	PTFE	PTFE	Acetal	-	ATEX pump. Solvents (ketones, acetates, aldehydes, aromatic and chlorinated hydrocarbons, toluene) and solvent based inks, paints and varnishes.

DP200 PLASTIC PUMPS

TECHNICAL DATA

Pressure ratio	1:1
Maximum free delivery (1)	200 l/min (53 gal/min)
Delivery per stroke approx. (1)	0,5 litres (0.13 US gal)
Delivery per cycle (2 x strokes) (1)	1 litre (0.26 US gal)
Air pressure operating range	1,5 to 8 bar (22 to 115 psi)
Solids in suspension max. size	6 mm (1/4")
Maximum dry suction lift (1)	5 m (16')
Maximum wet suction lift (1)	8 m (26')
Weight	10,5 kg (23.15 lb)
Fluid inlet connection	1" DIN PN-10 DN25 flange and ANSI B16.5 1" 150 lb flange
Fluid outlet connection	1" DIN PN-10 DN25 flange and ANSI B16.5 1" 150 lb flange
Air inlet connection	3/8" NPSM (F)
Wetted part materials	See recommended models

(1) Data measured with water, air inlet pressure 7 bar (100 psi), 20 °C (68 °F).

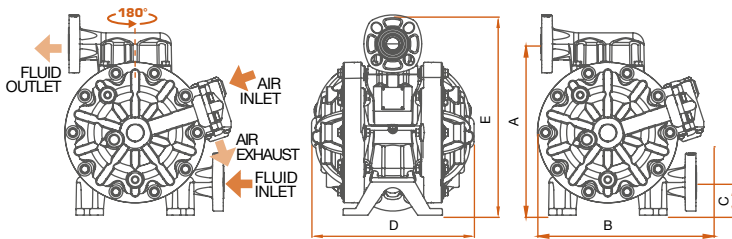

Dimensions (mm)

A	B	C	D
311	320	60	295

E	F*	H	I
364	9	154	175

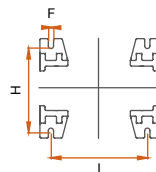

* Diameter of the holes for fasteners in each of the four pump feet.

PERFORMANCE CURVES

Tested at room temperature, with water and flooded pump with 800 mm (31 1/2") height of water above the pump inlet.

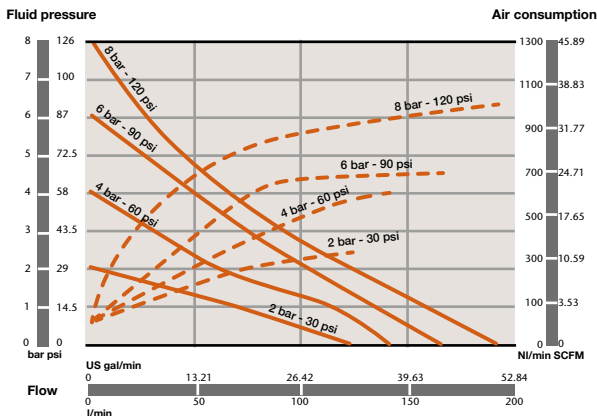

— Outlet pressure
- - - Air consumption

(*) 2 bar test with a pump fitted with PTFE (Teflon®) diaphragms.

DP200 PLASTIC PUMP CODING SYSTEM

1	2	3	4	5	6	7	8	9	10
DP200	P	P	S	E	M	T	M	F	AS

1 PUMP SIZE

DP200

2 AIR MOTOR: DIRECTIONAL VALVE & AIR CHAMBER COVERS

P = Polypropylene

3 WETTED PUMP BODY

P = Polypropylene

B = Conductive Polypropylene (ATEX pump)

D = Conductive Acetal (ATEX pump)

W = PVDF

K = Conductive PVDF (ATEX pump)

4 PUSH ROD

S = Stainless Steel AISI 420

Y = Hastelloy® C

5 SEALS

V = FKM (Viton®)

E = EPDM

T = PTFE (Teflon®)

6 CHECK VALVE SEATS

P = Polypropylene

C = Acetal

W = PVDF

M = Santoprene®

H = TPE (Hytrel®)

7 CHECK VALVE BALLS

T = PTFE (Teflon®)

C = Acetal

S = Stainless Steel AISI 316

8 DIAPHRAGMS

T = PTFE (Teflon®)

M = Santoprene®

H = TPE (Hytrel®)

9 FLUID CONNECTION THREADS

F = Flange

10 OPTIONS

AS = Standard pump

BS = Remote air exhaust *

DS = Stroke sensor

FS = Extra muffler

* Included in all DP200 pumps

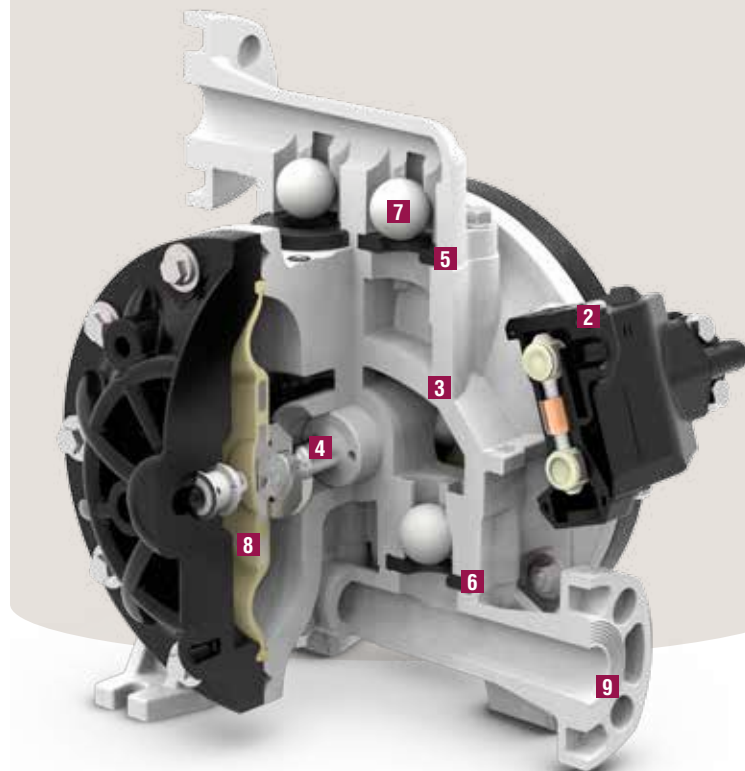

Original Directflo® Technology

DF50 METAL PUMPS

Air operated double diaphragm pumps for dosing, spraying, transferring, evacuating and distributing a wide variety of fluids.

Ideal for standard applications with small to medium flow rates.

Very robust metal pumps designed for the toughest applications.

Fully groundable ATEX certified pumps for use in potentially explosive atmospheres (Ex II2 GD IIB/IIC 95 °C).

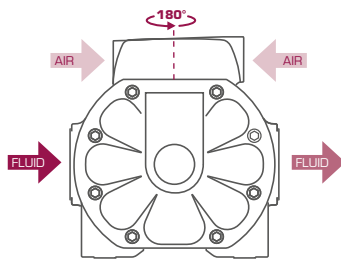

Orientable air inlet, increased installation flexibility.

1/2"
50 l/min
14 US gal/min



RECOMMENDED MODELS

MODEL	PUMP BODY	DIAPHRAGMS	BALLS	SEATS	OTHER WETTED MATERIALS	RECOMMENDED APPLICATIONS	
DF50AASNSNBAS	Aluminium	Buna-N	Buna-N	Stainless Steel	-	ATEX pump. Coolant, new and waste oil cutting, fluids, diesel.	
DF50AASVSTHBAS	Aluminium	TPE	PTFE	Stainless Steel	FKM	ATEX pump. Coolant, oil, cutting fluids. Water and Ph neutral aqueous solutions. Bilge water.	
DF50AASESTMBAS	Aluminium	Santoprene®	PTFE	Stainless Steel	EPDM	ATEX pump. Water based flexo and gravure inks and paints. Some types of glue.	
DF50AASTSTTBAS	Aluminium	PTFE	PTFE	Stainless Steel	-	ATEX pump. Chemicals compatible with stainless steel and aluminium. Solvents (ketones, acetates and aldehydes, aliphatic and aromatic hydrocarbons) and solvent based paint, inks and varnishes. NOT FOR CHLORINATED HYDROCARBON SOLVENTS.	
DF50AASTSSTBAS	Aluminium	PTFE	Stainless Steel	Stainless Steel	-	ATEX pump. Chemicals compatible with stainless steel and aluminium. Solvents (ketones, acetates and aldehydes, aliphatic and aromatic hydrocarbons) and solvent based paint, inks and varnishes. Stainless steel balls allow its use with higher viscosity fluids. NOT FOR CHLORINATED HYDROCARBON SOLVENTS.	
DF50ASSTSTTBAS	Stainless Steel	PTFE	PTFE	Stainless Steel	-	ATEX pump. Chemicals compatible with stainless steel. Solvent based paint, inks and varnishes.	
DF50ASSTSSTBAS	Stainless Steel	PTFE	Stainless Steel	Stainless Steel	-	ATEX pump. Chemicals compatible with stainless steel. Solvent based paint, inks and varnishes. Stainless steel balls allow its use with higher viscosity fluids.	

WARNING: DO NOT USE aluminium body pumps with halogenated hydrocarbon solvents.

DF50 METAL PUMPS

TECHNICAL DATA

Pressure ratio	1:1
Maximum free delivery (1)	50 l/min (14 US gal/min)
Delivery per stroke approx. (1)	0,1 litres (0.026 US gal)
Delivery per cycle (2 x strokes) (1)	0,25 litres (0.05 US gal)
Air pressure operating range	1,5 to 8 bar (22 to 115 psi)
Solids in suspension max. size	3 mm (1/8")
Maximum dry suction lift (1)	6 m (20')
Maximum wet suction lift (1)	8 m (26')
Weight	3,5 kg (7.72 lb)
Fluid inlet connection	1/2" NPSM (F)
Fluid outlet connection	1/2" NPSM (F)
Air inlet connection	3/8" NPSM (F)
Wetted part materials	See recommended models

(1) Data measured with water, air inlet pressure 7 bar (100 psi), 20 °C (68 °F).

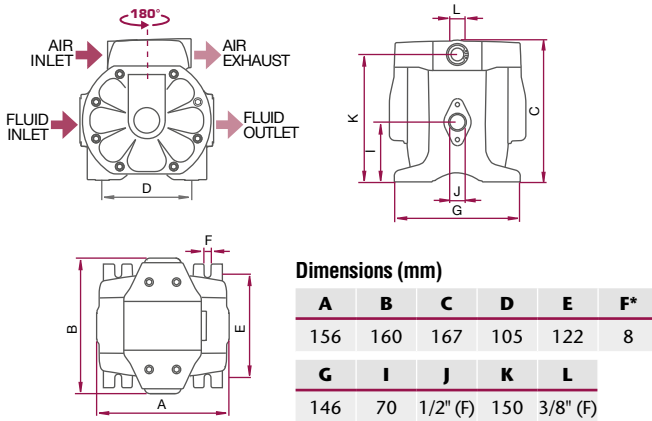

* Diameter of the holes for fasteners in each of the four pump feet.

PERFORMANCE CURVES

Tested at room temperature, with water and flooded pump with 800 mm (31 1/2") height of water above the pump inlet.

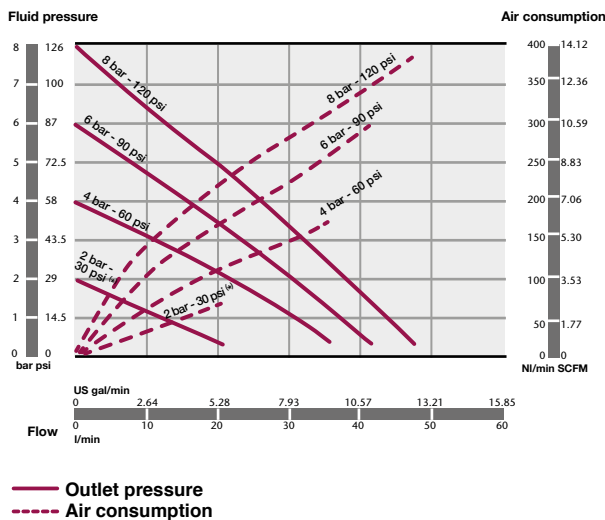

(*) 2 bar test with a pump fitted with PTFE (Teflon®) diaphragms.

DF50 METAL PUMP CODING SYSTEM

1	2	3	4	5	6	7	8	9	10
DF50	A	A	S	N	S	N	N	B	AS

1 PUMP SIZE

DF50

2 AIR MOTOR: DIRECTIONAL VALVE & AIR CHAMBER COVERS

A = Aluminium

3 WETTED PUMP BODY

A = Aluminium

S = Stainless Steel AISI 316

4 PUSH ROD

S = Stainless Steel AISI 420

5 SEALS

N = Buna-N

V = FKM (Viton®)

E = EPDM

T = PTFE (Teflon®)

6 CHECK VALVE SEATS

S = Stainless Steel AISI 316

7 CHECK VALVE BALLS

T = PTFE (Teflon®)

N = Buna-N

S = Stainless Steel AISI 316

8 DIAPHRAGMS

T = PTFE (Teflon®)

N = Buna-N

H = TPE (Hytrel®)

M = Santoprene®

9 FLUID CONNECTION THREADS

B = BSP

N = NPT

10 OPTIONS

AS = Standard pump

BS = Remote air exhaust

ES = Externally driven

FS = Extra muffler

GS = NPN inductive external pump control sensor.

IS = ATEX inductive external pump control sensor.

JS = PNP inductive external pump control sensor

US = Special UV ink pump

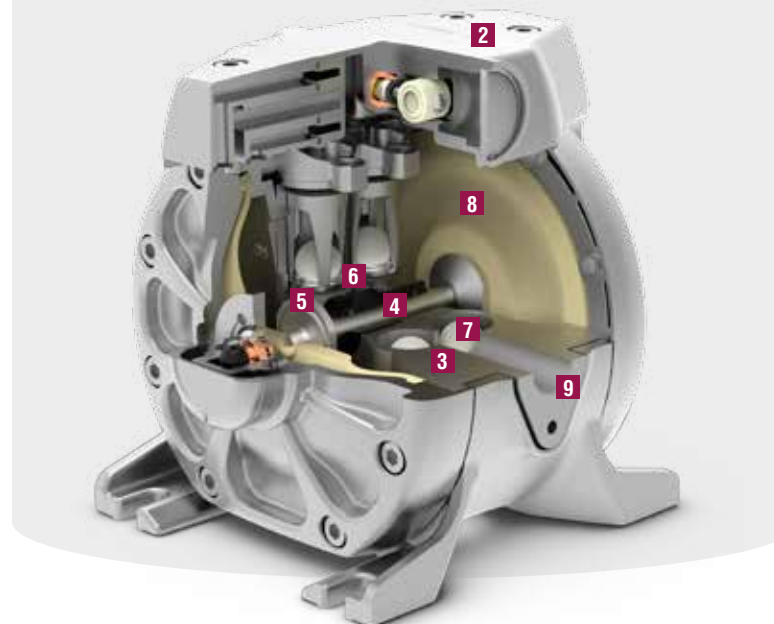

Original Directflo® Technology

DF100 METAL PUMPS

Air operated double diaphragm pumps for dosing, spraying, transferring, evacuating and distributing a wide variety of fluids.

Ideal for standard applications with medium flow rates.

Very robust metal pumps designed for the toughest applications.

Fully groundable ATEX certified pumps for use in potentially explosive atmospheres (Ex II2 GD IIB/IIC 95 °C).

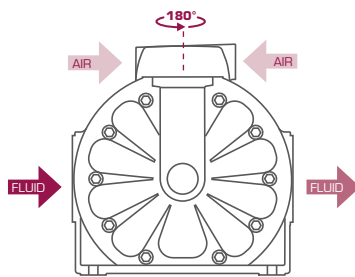

Orientable air inlet, increased installation flexibility.

1"
100 l/min
28 US gal/min



RECOMMENDED MODELS

MODEL	PUMP BODY	DIAPHRAGMS	BALLS	SEATS	OTHER WETTED MATERIALS	RECOMMENDED APPLICATIONS	
DF100AASNSNBAS	Aluminium	Buna-N	Buna-N	Stainless Steel	-	ATEX pump. Coolant, new and waste oil, cutting fluids, diesel.	Ex
DF100AASVSTHBAS	Aluminium	TPE	PTFE	Stainless Steel	FKM	ATEX pump. Coolant, oil, cutting fluids. Water and Ph neutral aqueous solutions. Bilge water.	Ex
DF100AASESTMBAS	Aluminium	Santoprene®	PTFE	Stainless Steel	EPDM	ATEX pump. Water based flexo and gravure inks and paints. Some types of glue.	Ex
DF100AASTSTTBAS	Aluminium	PTFE	PTFE	Stainless Steel	-	ATEX pump. Chemicals compatible with stainless steel and aluminium. Solvents (ketones, acetates and aldehydes, aliphatic and aromatic hydrocarbons) and solvent based paint, inks and varnishes. NOT FOR CHLORINATED HYDROCARBON SOLVENTS.	Ex
DF100AASTSTSBAS	Aluminium	PTFE	Stainless Steel	Stainless Steel	-	ATEX pump. Chemicals compatible with stainless steel and aluminium. Solvents (ketones, acetates and aldehydes, aliphatic and aromatic hydrocarbons) and solvent based paint, inks and varnishes. Stainless steel balls allow its use with higher viscosity fluids. NOT FOR CHLORINATED HYDROCARBON SOLVENTS.	Ex
DF100ASSTSTTBAS	Stainless Steel	PTFE	PTFE	Stainless Steel	-	ATEX pump. Chemicals compatible with stainless steel. Solvent based paint, inks and varnishes.	Ex
DF100ASSTSTSBAS	Stainless Steel	PTFE	Stainless Steel	Stainless Steel	-	ATEX pump. Chemicals compatible with stainless steel. Solvent based paint, inks and varnishes. Stainless steel balls allow its use with higher viscosity fluids.	Ex

WARNING: DO NOT USE aluminium body pumps with halogenated hydrocarbon solvents.

DF100 METAL PUMPS

TECHNICAL DATA

Pressure ratio	1:1
Maximum free delivery (1)	100 l/min (28 US gal/min)
Delivery per stroke approx. (1)	0,25 litres (0.07 US gal)
Delivery per cycle (2 x strokes) (1)	0,5 litres (0.13 US gal)
Air pressure operating range	1,5 to 8 bar (22 to 115 psi)
Solids in suspension max. size	4 mm (3/16")
Maximum dry suction lift (1)	4,5 m (15')
Maximum wet suction lift (1)	7 m (23')
Weight	7,2 kg (16 lb)
Fluid inlet connection	1" BSP/NPT (F)
Fluid outlet connection	1" BSP/NPT (F)
Air inlet connection	3/8" NPSM (F)
Wetted part materials	See recommended models

(1) Data measured with water, air inlet pressure 7 bar (100 psi), 20 °C (68 °F).

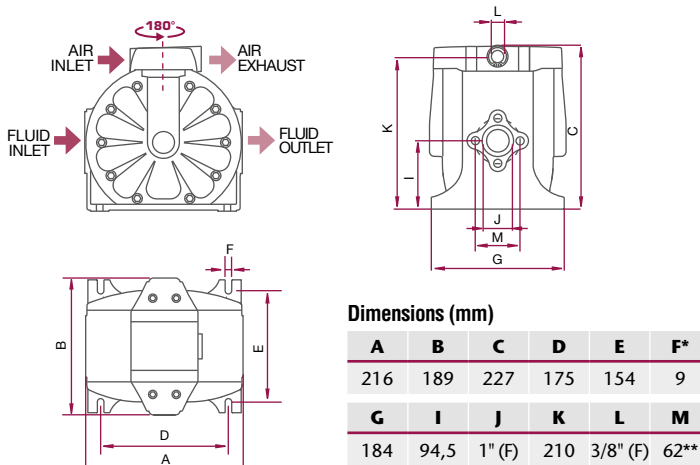

* Diameter of the holes for fasteners in each of the four pump feet.
** Flange connection: 2 bolts - M 5 (41 mm between centres).

PERFORMANCE CURVES

Tested at room temperature, with water and flooded pump with 800 mm (31 1/2") height of water above the pump inlet.

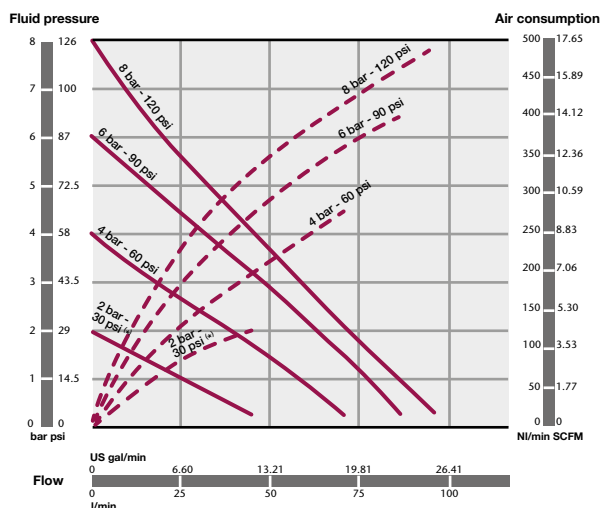

(*) 2 bar test with a PTFE (Teflon®) diaphragms pump.

DF100 METAL PUMP CODING SYSTEM

1	2	3	4	5	6	7	8	9	10
DF100	A	A	S	N	S	N	N	B	AS

1 PUMP SIZE

DF100

2 AIR MOTOR: DIRECTIONAL VALVE & AIR CHAMBER COVERS

A = Aluminium

3 WETTED PUMP BODY

A = Aluminium

S = Stainless Steel AISI 316

4 PUSH ROD

S = Stainless Steel AISI 420

5 SEALS

N = Buna-N

V = FKM (Viton®)

E = EPDM

T = PTFE (Teflon®)

6 CHECK VALVE SEATS

S = Stainless Steel AISI 316

7 CHECK VALVE BALLS

T = PTFE (Teflon®)

N = Buna-N

S = Stainless Steel AISI 316

8 DIAPHRAGMS

T = PTFE (Teflon®)

N = Buna-N

H = TPE (Hytrell®)

M = Santoprene®

9 FLUID CONNECTION THREADS

B = BSP

N = NPT

10 OPTIONS

AS = Standard pump

BS = Remote air exhaust

DS = Stroke sensor

ES = Externally driven

FS = Extra muffler

GS = NPN inductive external pump control sensor.

IS = ATEX inductive external pump control sensor.

JS = PNP inductive external pump control sensor

US = Special UV ink pump

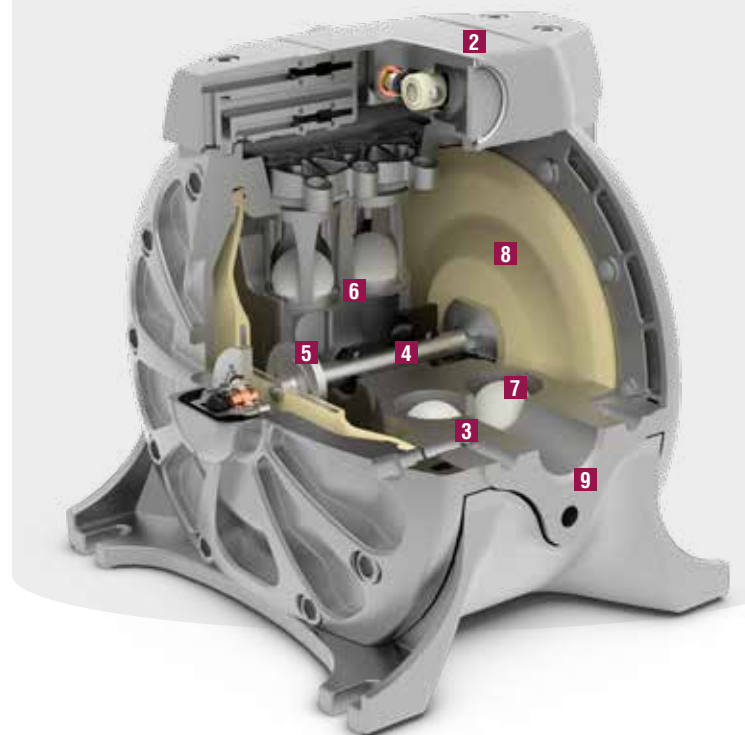

Original Directflo® Technology

DF250 METAL PUMPS

High flow air operated double diaphragm pumps for dosing, spraying, transferring, evacuating and distributing a wide variety of fluids.

Ideal for standard applications with high flow rates.

Very robust metal pumps designed for the toughest applications.

Fully groundable ATEX certified pumps for use in potentially explosive atmospheres (Ex II2 GD IIB/ IIC 95 °C).



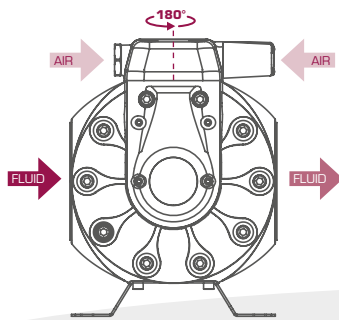

1 1/2"
250 l/min
66 US gal/min

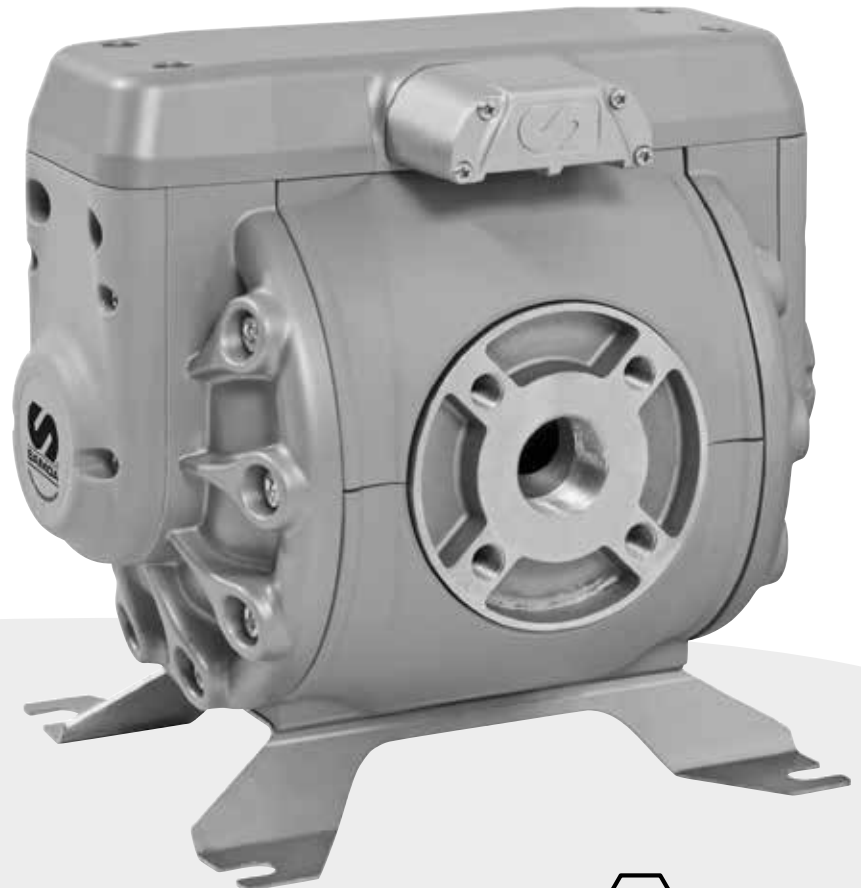

Orientable air inlet, increased installation flexibility.



RECOMMENDED MODELS

MODEL	PUMP BODY	DIAPHRAGMS	BALLS	SEATS	OTHER WETTED MATERIALS	RECOMMENDED APPLICATIONS
DF250AASNSNBAS	Aluminium	Buna-N	Buna-N	Stainless Steel	-	ATEX pump. Coolant, new and waste oil, cutting fluids, diesel. 
DF250AASVSTHBAS	Aluminium	TPE	PTFE	Stainless Steel	FKM	ATEX pump. Coolant fluids, oil, water and Ph neutral aqueous solutions, bilge water, hydraulic fluids. 
DF250AASESTMBAS	Aluminium	Santoprene®	PTFE	Stainless Steel	EPDM	ATEX pump. Water based flexo and gravure inks and paint. Some types of glue. 
DF250AASTSTTBAS	Aluminium	PTFE	PTFE	Stainless Steel	-	ATEX pump. Chemicals compatible with stainless steel and aluminium. Solvents (ketones, acetates and aldehydes, aliphatic and aromatic hydrocarbons) and solvent based paint, inks and varnishes. NOT FOR CHLORINATED HYDROCARBON SOLVENTS. 
DF250AASTSSTBAS	Aluminium	PTFE	Stainless Steel	Stainless Steel	-	ATEX pump. Chemicals compatible with stainless steel and aluminium. Solvents (ketones, acetates and aldehydes, aliphatic and aromatic hydrocarbons) and solvent based paint, inks and varnishes. Stainless steel balls allow its use with higher viscosity fluids. NOT FOR CHLORINATED HYDROCARBON SOLVENTS. 

WARNING: DO NOT USE aluminium body pumps with halogenated hydrocarbon solvents.

DF250 METAL PUMPS

TECHNICAL DATA

Pressure ratio	1:1
Maximum free delivery (1)	250 l/min (66 US gal/min)
Delivery per stroke approx. (1)	0,6 litres (0.16 US gal)
Delivery per cycle (2 x strokes) (1)	1,2 litres (0.32 US gal)
Air pressure operating range	1,5 to 8 bar (22 to 115 psi)
Solids in suspension max. size	6 mm (1/4")
Maximum dry suction lift (1)	5 m (16')
Maximum wet suction lift (1)	8 m (26')
Weight	20 kg (45 lb)
Fluid inlet connection	1 1/2" BSP (F) and DIN PN-10 DN40 flange or 1 1/2" NPT (F) and ANSI 1" B16.5 150 lb flange
Fluid outlet connection	1 1/2" BSP (F) and DIN PN-10 DN40 flange or 1 1/2" NPT (F) and ANSI 1" B16.5 150 lb flange
Air inlet connection	1/2" NPSM (F)
Wetted part materials	See recommended models

(1) Data measured with water, air inlet pressure 7 bar (100 psi), 20 °C (68 °F).

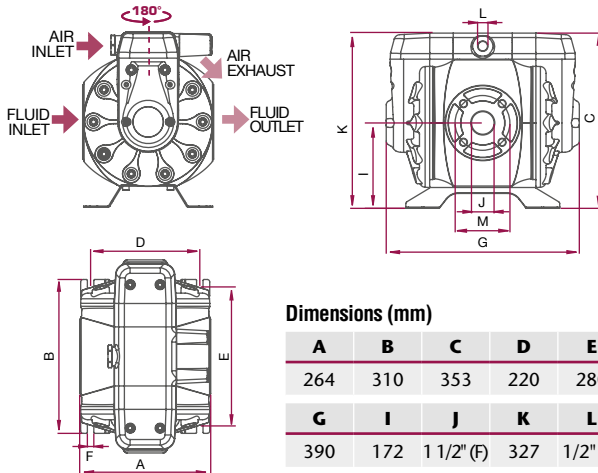

Dimensions (mm)

A	B	C	D	E	F*
264	310	353	220	280	13
G	I	J	K	L	M
390	172	1 1/2" (F)	327	1/2" (F)	110**

* Diameter of the holes for fasteners in each of the four pump feet.
 ** DIN PN-10 flange connection: 4 bolts - M 16 (110 mm between centres).
 ** ANSI B16.5 150 lb flange connection: 4 bolts - UNC 1/2" - 13 (98,4 mm between centres).

PERFORMANCE CURVES

Tested at room temperature, with water and flooded pump with 800 mm (31 1/2") height of water above the pump inlet.

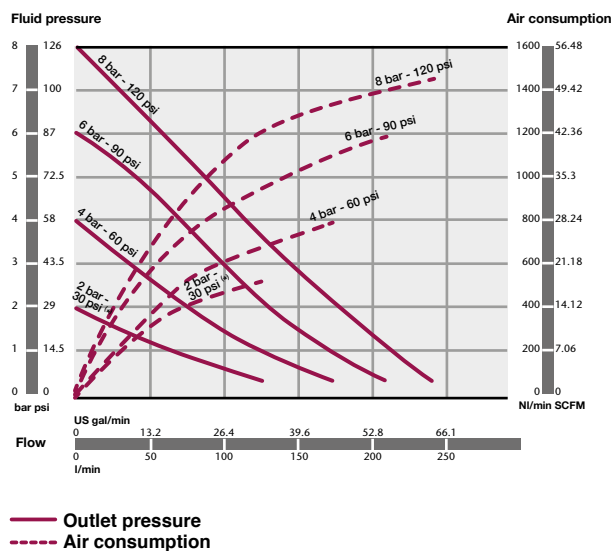

(*) 2 bar test with a pump fitted with TPE (Hytrel®) diaphragms.

DF250 METAL PUMP CODING SYSTEM

1	2	3	4	5	6	7	8	9	10
DF250	A	A	S	N	S	N	N	B	AS

1 PUMP SIZE

DF250

2 AIR MOTOR: DIRECTIONAL VALVE & AIR CHAMBER COVERS

A = Aluminium

3 WETTED PUMP BODY

A = Aluminium

4 PUSH ROD

S = Stainless Steel AISI 420

5 SEALS

N = Buna-N
 V = FKM (Viton®)
 E = EPDM
 T = PTFE (Teflon®)

6 CHECK VALVE SEATS

S = Stainless Steel AISI 316

7 CHECK VALVE BALLS

T = PTFE (Teflon®)
 N = Buna-N
 S = Stainless Steel AISI 316
 C = Acetal

8 DIAPHRAGMS

T = PTFE (Teflon®)
 N = Buna-N
 H = TPE (Hytrel®)
 M = Santoprene®

9 FLUID CONNECTION THREADS

B = BSP
 N = NPT

10 OPTIONS

AS = Standard pump
 BS = Remote air exhaust *
 DS = Stroke sensor
 FS = Extra muffler

* Included in all DF250 pumps

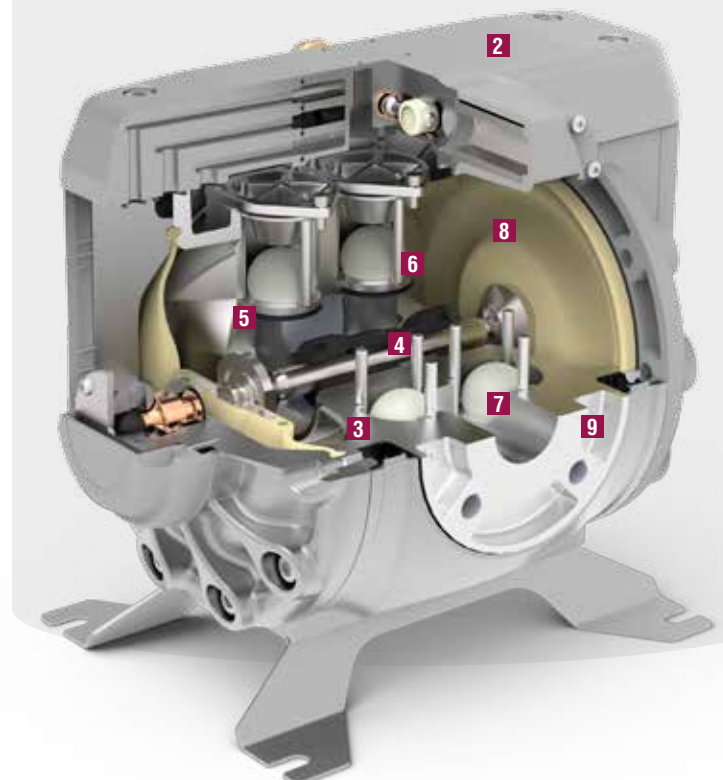

Enhanced Leading Technology

DP200 METAL PUMPS

Air operated double diaphragm pumps for dosing, spraying, transferring, evacuating and distributing a wide variety of fluids.

Designed for maximum performance and efficiency with high flow rates.

Very robust metal pumps designed for the toughest applications.

Fully groundable ATEX certified pumps for use in potentially explosive atmospheres (Ex II2 GD IIB/IIC 95 °C).

1"
200 l/min
53 US gal/min

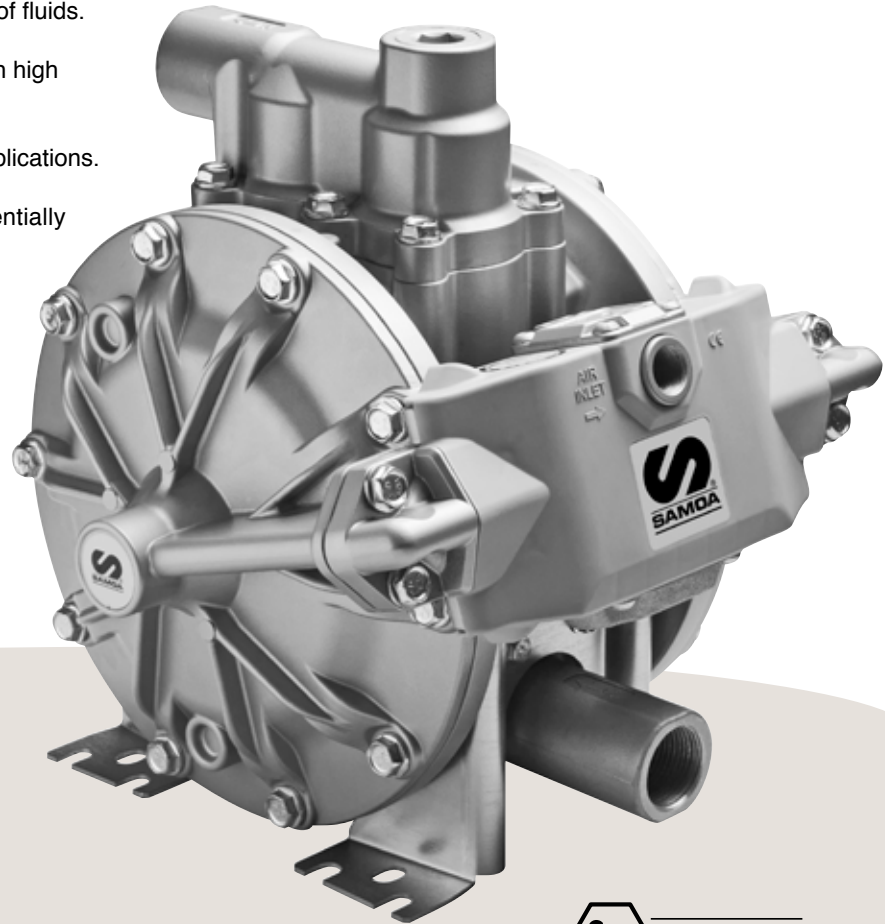
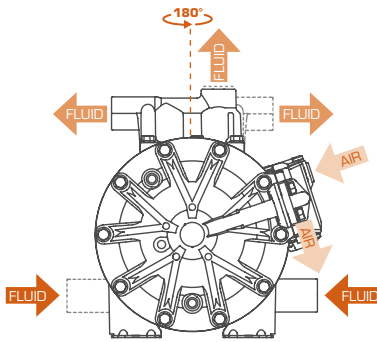

Orientable ports, increased installation versatility.



RECOMMENDED MODELS

MODEL	PUMP BODY	DIAPHRAGMS	BALLS	SEATS	OTHER WETTED MATERIALS	RECOMMENDED APPLICATIONS
DP200AASNANNBAS	Aluminium	Buna-N	Buna-N	Aluminium	-	ATEX pump. Coolant, new and waste oil, cutting fluids, diesel.
DP200AASVHTHBAS	Aluminium	TPE	PTFE	TPE	FKM	ATEX pump. Coolant fluids, water and Ph neutral aqueous solutions, bilge water, hydraulic fluids.
DP200AASEMTMBAS	Aluminium	Santoprene®	PTFE	Santoprene®	EPDM	ATEX pump. Water based flexo and gravure inks. Water based paint. Some types of glue.
DP200AASTATTBAS	Aluminium	PTFE	PTFE	Aluminium	-	ATEX pump. Chemicals compatible with stainless steel and aluminium. Solvents (ketones, acetates and aldehydes, aliphatic and aromatic hydrocarbons) and solvent based paint, inks and varnishes. NOT FOR CHLORINATED HYDROCARBON SOLVENTS.
DP200AASTASTBAS	Aluminium	PTFE	Stainless Steel	Aluminium	-	ATEX pump. Chemicals compatible with stainless steel and aluminium. Solvents (ketones, acetates and aldehydes, aliphatic and aromatic hydrocarbons) and solvent based paint, inks and varnishes. Stainless steel balls allow its use with higher viscosity fluids. NOT FOR CHLORINATED HYDROCARBON SOLVENTS.
DP200ASSTSTTBAS	Stainless Steel	PTFE	PTFE	Stainless Steel	-	ATEX pump. Chemicals compatible with stainless steel. Solvent based paint, inks and varnishes.
DP200ASSTSSTBAS	Stainless Steel	PTFE	Stainless Steel	Stainless Steel	-	ATEX pump. Chemicals compatible with stainless steel. Solvent based paint, inks and varnishes. Stainless steel balls allow its use with higher viscosity fluids.

WARNING: DO NOT USE aluminium body pumps with halogenated hydrocarbon solvents.

DP200 METAL PUMPS

TECHNICAL DATA

Pressure ratio	1:1
Maximum free delivery (1)	200 l/min (53 gal/min)
Delivery per stroke approx. (1)	0,5 litres (0.13 US gal)
Delivery per cycle (2 x strokes) (1)	1 litre (0.26 US gal)
Air pressure operating range	1,5 to 8 bar (22 to 115 psi)
Solids in suspension max. size	6 mm (1/4")
Maximum dry suction lift (1)	5 m (16')
Maximum wet suction lift (1)	8 m (26')
Weight	11,5 kg (23.35 lb)
Fluid inlet connection	1" BSP/NPT (F)
Fluid outlet connection	1" BSP/NPT (F)
Air inlet connection	3/8" NPSM (F)
Wetted part materials	See recommended models

(1) Data measured with water, air inlet pressure 7 bar (100 psi), 20 °C (68 °F).

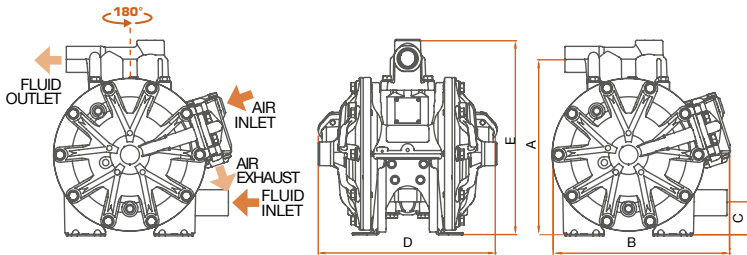

Dimensions (mm)

A	B	C	D	E	F*	G*/H*
278	280	52	281	308	9	10
I	J	K	L	M	N	O
158	154	137	127	102	140	175

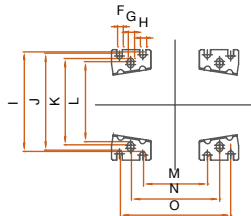

* Diameter of the holes for fasteners in each of the four pump feet.

PERFORMANCE CURVES

Tested at room temperature, with water and flooded pump with 800 mm (31 1/2") height of water above the pump inlet.

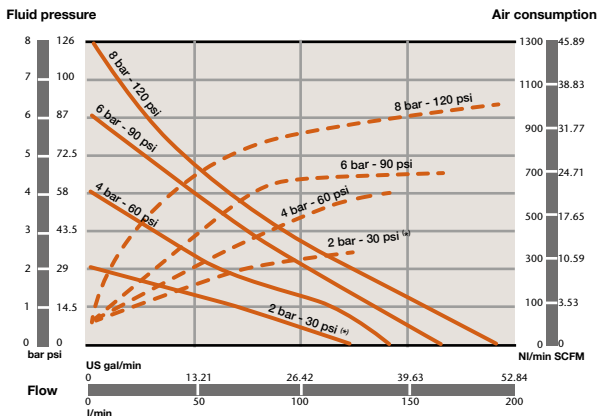

— Outlet pressure
- - - Air consumption

(*) 2 bar test with a pump fitted with PTFE (Teflon®) diaphragms.

DP200 METAL PUMP CODING SYSTEM

1	2	3	4	5	6	7	8	9	10
DP200	A	A	S	N	A	N	N	F	AS

1 PUMP SIZE

DP200

2 AIR MOTOR: DIRECTIONAL VALVE & AIR CHAMBER COVERS

A = Aluminium

3 WETTED PUMP BODY

A = Aluminium

S = Stainless Steel AISI 316

4 PUSH ROD

S = Stainless Steel AISI 420

5 SEALS

N = Buna-N

V = FKM (Viton®)

E = EPDM

T = PTFE (Teflon®)

6 CHECK VALVE SEATS

S = Stainless Steel AISI 316

A = Aluminium

N = Buna-N

M = Santoprene®

H = TPE (Hytrel®)

7 CHECK VALVE BALLS

T = PTFE (Teflon®)

N = Buna-N

S = Stainless Steel AISI 316

C = Acetal

8 DIAPHRAGMS

T = PTFE (Teflon®)

N = Buna-N

M = Santoprene®

H = TPE (Hytrel®)

9 FLUID CONNECTION THREADS

B = BSP

N = NPT

10 OPTIONS

AS = Standard pump

BS = Remote air exhaust

DS = Stroke sensor

FS = Extra muffler

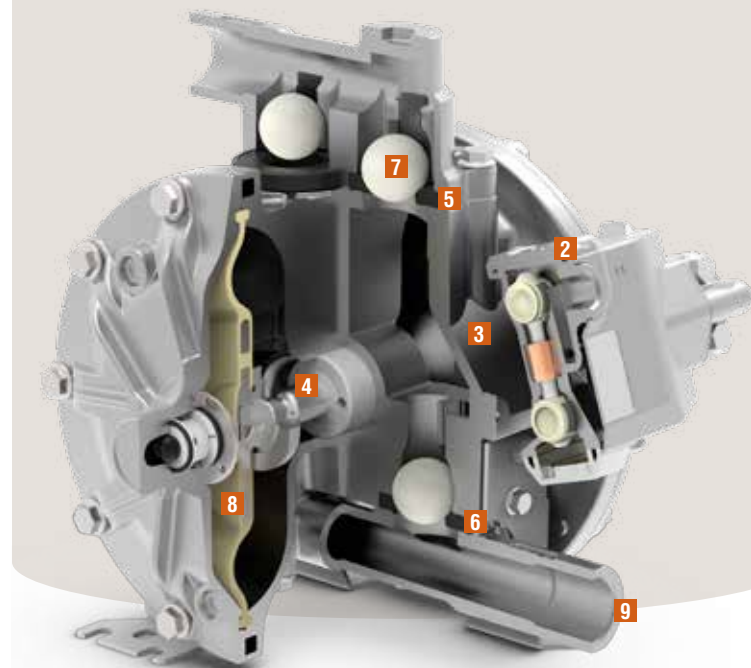

DIRECTFLO® PUMP CODING SYSTEM

MODEL EXAMPLE									
1	2	3	4	5	6	7	8	9	10
DF50	A	A	S	N	S	N	N	B	AS

1 PUMP SIZE	
DC20	1/4" - 3/4" 20 l/min (5.3 US gal/min) pump
DC30	1/2" 38 l/min (10 US gal/min) pump
DC50	1/2" 50 l/min (14 US gal/min) pump
DF30	1/2" 38 l/min (10 US gal/min) pump
DF30T	2 x 3/8" 38 l/min (10 US gal/min) dual inlet pump
DF50	1/2" 50 l/min (14 US gal/min) pump
DF50T	2 x 3/8" 50 l/min (14 US gal/min) dual inlet pump
DF100	1" 100 l/min (27 US gal/min) pump
DF250	1-1/2" 250 l/min (66 US gal/min) pump
DP200	1" 200 l/min (53 US gal/min) pump

2 AIR MOTOR: DIRECTIONAL AIR VALVE & AIR CHAMBER COVERS	
	DC20 DC30 DC50 DF30 DF30T DF50 DF50T DF100 DF250 DP200
A = Aluminium	● ● ● ● ● ● ● ● ● ●
P = Polypropylene	● ● ● ● ● ● ● ● ● ●

3 WETTED PUMP BODY	
	DC20 DC30 DC50 DF30 DF30T DF50 DF50T DF100 DF250 DP200
A = Aluminium	● ● ● ● ● ● ● ● ● ●
S = Stainless Steel AISI 316	● ● ● ● ● ● ● ● ● ●
P = Polypropylene	● ● ● ● ● ● ● ● ● ●
B = Conductive Polypropylene	● ● ● ● ● ● ● ● ● ●
D = Conductive Acetal	● ● ● ● ● ● ● ● ● ●
W = PVDF	● ● ● ● ● ● ● ● ● ●
K = Conductive PVDF	● ● ● ● ● ● ● ● ● ●

4 PUSH ROD	
	DC20 DC30 DC50 DF30 DF30T DF50 DF50T DF100 DF250 DP200
S = Stainless Steel AISI 420	● ● ● ● ● ● ● ● ● ●
Y = Hastelloy® C	● ● ● ● ● ● ● ● ● ●

5 SEALS	
	DC20 DC30 DC50 DF30 DF30T DF50 DF50T DF100 DF250 DP200
E = EPDM	● ● ● ● ● ● ● ● ● ●
V = FKM (Viton®)	● ● ● ● ● ● ● ● ● ●
T = PTFE (Teflon®)	● ● ● ● ● ● ● ● ● ●
N = Buna-N	● ● ● ● ● ● ● ● ● ●

6 CHECK VALVE SEATS	
	DC20 DC30 DC50 DF30 DF30T DF50 DF50T DF100 DF250 DP200
A = Aluminium	● ● ● ● ● ● ● ● ● ●
C = Acetal	● ● ● ● ● ● ● ● ● ●
H = TPE (Hytrel®)	● ● ● ● ● ● ● ● ● ●
M = Santoprene®	● ● ● ● ● ● ● ● ● ●
N = Buna-N	● ● ● ● ● ● ● ● ● ●
P = Polypropylene	● ● ● ● ● ● ● ● ● ●
S = Stainless Steel AISI 316	● ● ● ● ● ● ● ● ● ●
W = PVDF	● ● ● ● ● ● ● ● ● ●

7 CHECK VALVE BALLS	
	DC20 DC30 DC50 DF30 DF30T DF50 DF50T DF100 DF250 DP200
C = Acetal	● ● ● ● ● ● ● ● ● ●
N = Buna-N	● ● ● ● ● ● ● ● ● ●
S = Stainless Steel AISI 316	● ● ● ● ● ● ● ● ● ●
T = PTFE (Teflon®)	● ● ● ● ● ● ● ● ● ●

8 DIAPHRAGMS	
	DC20 DC30 DC50 DF30 DF30T DF50 DF50T DF100 DF250 DP200
H = TPE (Hytrel®)	● ● ● ● ● ● ● ● ● ●
M = Santoprene®	● ● ● ● ● ● ● ● ● ●
N = Buna-N	● ● ● ● ● ● ● ● ● ●
T = PTFE (Teflon®)	● ● ● ● ● ● ● ● ● ●

9 FLUID CONNECTION THREADS	
	DC20 DC30 DC50 DF30 DF30T DF50 DF50T DF100 DF250 DP200
B = BSP	● ● ● ● ● ● ● ● ● ●
N = NPT	● ● ● ● ● ● ● ● ● ●
F = Flange	● ● ● ● ● ● ● ● ● ●

10 OPTIONS	
	DC20 DC30 DC50 DF30 DF30T DF50 DF50T DF100 DF250 DP200
AS = Standard pump	● ● ● ● ● ● ● ● ● ●
BS = Remote air exhaust	● ⁽²⁾ ● ● ● ● ● ● ● ● ● ●
DS = Stroke sensor	● ● ● ● ● ● ● ● ● ●
ES = Externally driven	● ● ● ● ● ● ● ● ● ●
FS = Extra muffler	● ● ● ● ● ● ● ● ● ●
GS = NPN inductive external pump control sensor	● ● ● ● ● ● ● ● ● ●
IS = ATEX inductive external pump control sensor	● ● ● ● ● ● ● ● ● ●
JS = PNP inductive external pump control sensor	● ● ● ● ● ● ● ● ● ●
US = Special UV ink pump	● ● ● ● ● ● ● ● ● ●

(1) Pumps with PTFE diaphragms only
 (2) Included in all DC20 and DF250 pumps

EPDM = Ethylene Propylene Diene Monomer Rubber
 FKM = Fluoroelastomer (Viton®)
 Buna-N = NBR, Nitrile Butadiene Rubber
 PTFE = Polytetrafluoroethylene (Teflon®)
 PVDF = Polyvinylidene Fluoride (Kynar® or Solef®)
 TPE = Thermoplastic Elastomer (Hytrel®)

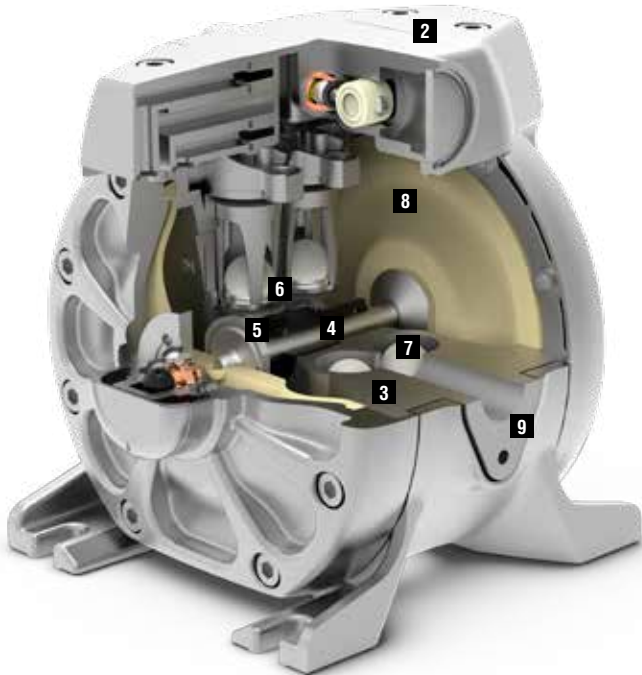

Hytrel®, Teflon® and Viton® are registered trademarks of E. I. du Pont de Nemours and Company or its affiliates.
 Hastelloy® is a registered trademark of Haynes International, Inc.
 Kynar® is a registered trademark of Arkema.
 Santoprene® is a registered trademark of Exxon Mobil Chemical.
 Solef® is a registered trademark of Solvay Solexis S.p.A.

THERE'S A DIRECTFLO® PUMP FOR ALMOST EVERY APPLICATION

MARKETS SERVED		1	2	3	4	5	6	7	8	9	10
APPLICATIONS		FLUID TRANSFER AND DISPENSING	FLUID EVACUATION	DOSING/BLENDING/FORMULATION	FLUID RECIRCULATION	SUPPLY FOR LOW PRESSURE SPRAY	FLUID FLUSHING/CLEAN IN PLACE (CIP)	PUMPING SAMPLES	FILTER & FILTER PRESS FEEDING	SLURRY HANDLING	TANK/BARREL FILLING & EMPTYING
A	VEHICLE PRODUCTION & MAINTENANCE • Cars, motorbikes & trucks • Construction, mining & agriculture • Ships & airplanes • Railway	O, AF, WS, HF, BF, BL, D, U, W	WO, WA								
B	CONSTRUCTION & MINING • Concrete batching plants • Pit dewatering	CA, CS	W	CA, AA, CS	CS					CS	
C	PRINT & PACKAGING • Printing presses • Ink dispensers & blenders • Cylinder cleaning • Solvent recovery	FI, GI, GL, S, WC	WC, WW	FI, GI	FI, GI, S, W	S, W	S, W, CF				
D	PULP & PAPER CONVERTERS • Paper plants	CO, BC, GL	WW					SW			
E	PAINT & COATINGS • Paint & varnish lines • Paint formulation • Colour mixers • Paint gun washers	P, C, S, V, R, ST	WC	P, C, V, R	P, C, V, R	P, C, S			MO	CS	
F	PROCESS WATER • Commercial laundries • Car washes • Power stations	DT, WX, CF, W, WW	WW	SA, DG, BC, FS		DT, WX, CF					
G	SURFACE TREATMENTS • Plating lines • Degreasing & treatment lines • Pickling lines	AC, AK, AT, S, DG	WC, WW								AC, AK, S, DG
H	WASTEWATER TREATMENT • Industrial water treatment plants • Municipal sewage works	FC, CG, BC, AC, AK	WC, WW	FC, CG, BO, DI				SW	WW		
I	METALWORKING • Lathes & machining centres • Waste fluid recovery • Part washing • Corrosion protection	MC, MO, S, CF, DG, W	MC, MO, WW, WC		MC, W, DG, S	O, DG, S, W					
J	CHEMICAL, PETROCHEMICAL & REFINERIES	AC, AK, AL, S, LX, CH	WC, W, CH	FA, CH, OA				CH			CH
K	HYGIENIC • Food & beverage • Food processing plants • Biotechnology • Pharmaceutical	AC, AK				CF	CF, AC, AK				
L	CERAMIC • Ceramic manufacturers	EN, BB, W	WW							EN, BB	

- | | | | | | |
|--------------------------------|---------------------------|-----------------------------|-------------------------------------------------|---------------------------------|------------------------------|
| AA: Asphalt Additive | BL: Battery Liquid | D: Diesel | FS: Fabric Softener | OA: Oil Additive | W: Water |
| AC: Acid | BO: Biocide | DG: Degreaser | GI: Gravure Ink | P: Paint | WA: Waste Antifreeze |
| AK: Alkali | C: Coating | DI: Disinfectant | GL: Glue | R: Resin | WC: Waste Chemical |
| AL: Alcohol | CA: Concrete Admix | DT: Detergent | HF: Hydraulic Fluid / Skydro® (airplane) | S: Solvent | WO: Waste Oil |
| AT: Acetone | CF: Cleaning Fluid | EM: Emulsions | LX: Latex | SA: Soap | WS: Windshield Washer |
| AF: Antifreeze, coolant | CG: Coagulant | EN: Enamel (ceramic) | MC: Machine Coolant | ST: Wood Stain | WX: Wax |
| BF: Brake Fluid | CH: Chemicals | FA: Fuel Additive | MO: Machining (cutting) Oil | SW: Water based Solution | WW: Waste Water |
| | CO: Colour | FC: Flocculent | O: Oil | U: Urea solution (DEF) | |
| | CS: Colour Slurry | FI: Flexo Ink | | V: Varnish | |

