



CAR FILLING



FUEL MANAGEMENT SYSTEMS



KITS



PUMPS



METERS



METERED NOZZLES

SB325_X

FEATURES

- HEAVY DUTY
- VERSATILE
- BREAK-AWAY SYSTEM
- ERGONOMIC DESIGN

The SB325_X is the patented automatic nozzle by PIUSI for AdBlue®, equipped with break-away system and stainless steel spout. Designed in compliance with International Standards ISO/ FDIS 22241-4:2009, it also features a reliable, ergonomic, and flexible shell that protects the nozzle against weathering and UV radiation.

Safety is guaranteed by the break-away system. In the event that a vehicle accidentally drives away with the nozzle still in the tank, the spout is designed to detach from the nozzle. This system also allows for a quick repair by merely fitting a new spout onto the nozzle.

PERFORMANCE

UP TO

45 L/MIN

FLOW RATE

3,5 BAR

MAX

OPERATING PRESSURE



SB325_X



PACKAGING

CODE	WEIGHT		PACKAGING		
	KG	LBS	MM	INCH	PCS/BOX
FO061700A	0,7	1,5	447X178X85	17,6X7X2,5	1



NOZZLES



FILTRATION



TANK MONITORING



HOSE REEL



ACCESSORIES



MERCHANDISE

INDEX



AIR



ANTIFREEZE



AdBlue®



BIODIESEL



DIESEL



FOOD



GASOLINE



GREASE



KEROSENE



OIL



WATER



WINDSCREEN

CHART

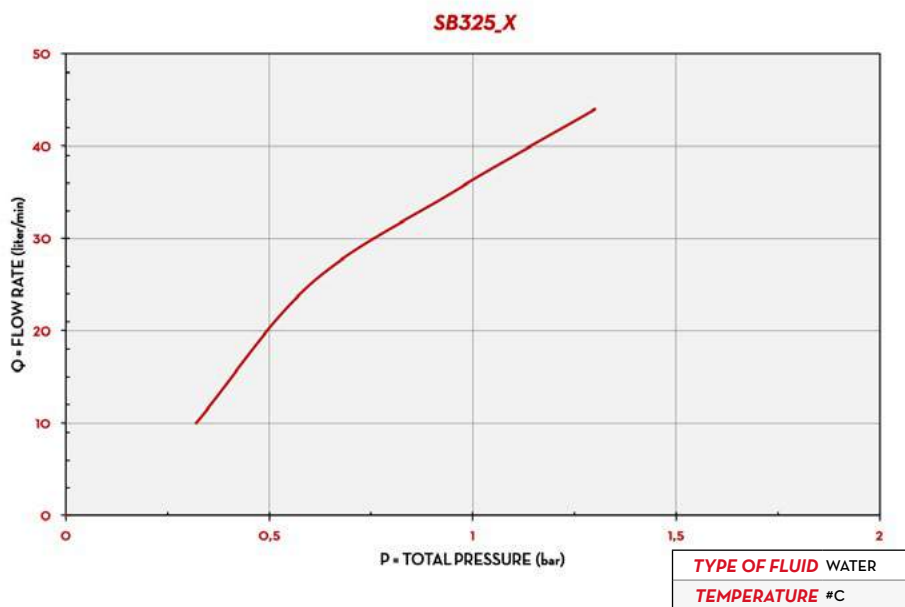

IN THE BOX

- SB325_X NOZZLE
- INSTRUCTION MANUAL

DETAILS



STAINLESS STEEL SPOUT



BREAK-AWAY SYSTEM

DIMENSIONS

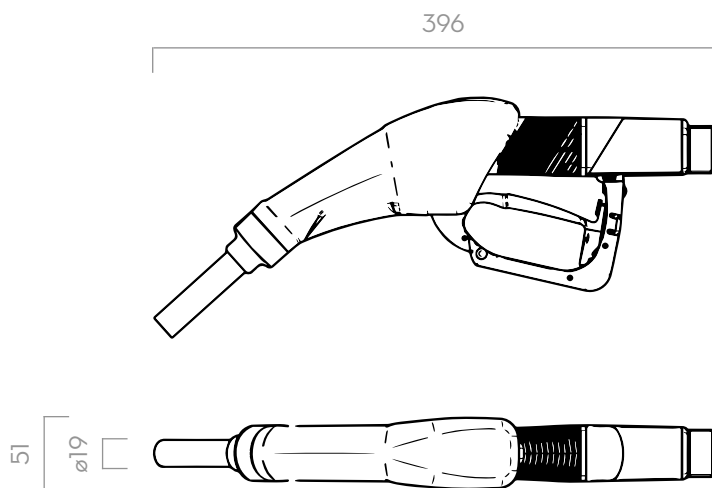

Dimensions expressed in millimeters

MATERIALS

- SPOUT: STAINLESS STEEL
- BODY: TECHNOPYLIMER

TECHNICAL DATA

CODE	DESCRIPTION	FLUIDS TYPE	FLOW RATE		MAGNETIC ADAPTOR	METER	PRESSURE	INLET	SWIVEL	SPOUT
			L/MIN	GPM			BAR			EXT. Ø
FO061700A	AUTOMATIC NOZZLE SB325_X		45	12	NO	NO	3,5	3/4"	YES	19 MM

SB325_X