



CAR FILLING



FUEL MANAGEMENT SYSTEMS



KITS



PUMPS



METERS



METERED NOZZLES

MK325 METER

FEATURES

- MID EVALUATION CERTIFICATE
- LOW INVESTMENT INSTALLATION
- LOW MAINTENANCE COSTS
- BI-DIRECTIONAL MEASUREMENT
- ATEX PENDING
- EX-D PROTECTION

The PIUSI MK325 is a new and innovative flow meter specifically engineered for AdBlue® MID measuring. It can be installed both in fixed and mobile dispensing systems.

PERFORMANCE

±0,3%

ACCURACY

20 BAR

MAX

OPERATING PRESSURE

UP TO

35 L/MIN

FLOW RATE

0,2%

REPEATABILITY



MK325

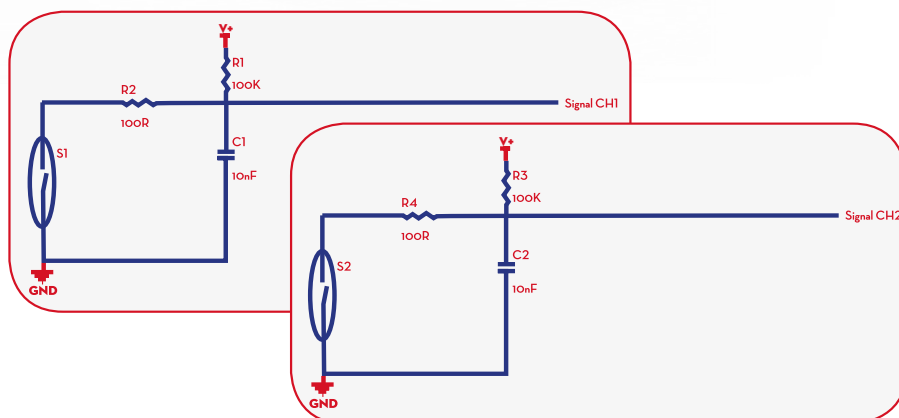

ELECTRICAL SCHEME

PACKAGING

CODE	WEIGHT		PACKAGING		
	KG	LBS	MM	INCH	PCS/BOX
FOO476X00	22	4,85	190X140X160	7,48X5,51X6,3	1



NOZZLES



FILTRATION



TANK MONITORING



HOSE REEL



ACCESSORIES



MERCHANDISE

INDEX



AIR



ANTIFREEZE



AdBlue®



BIODIESEL



DIESEL



FOOD



GASOLINE



GREASE



KEROSENE



OIL



WATER



WINDSCREEN

CHART

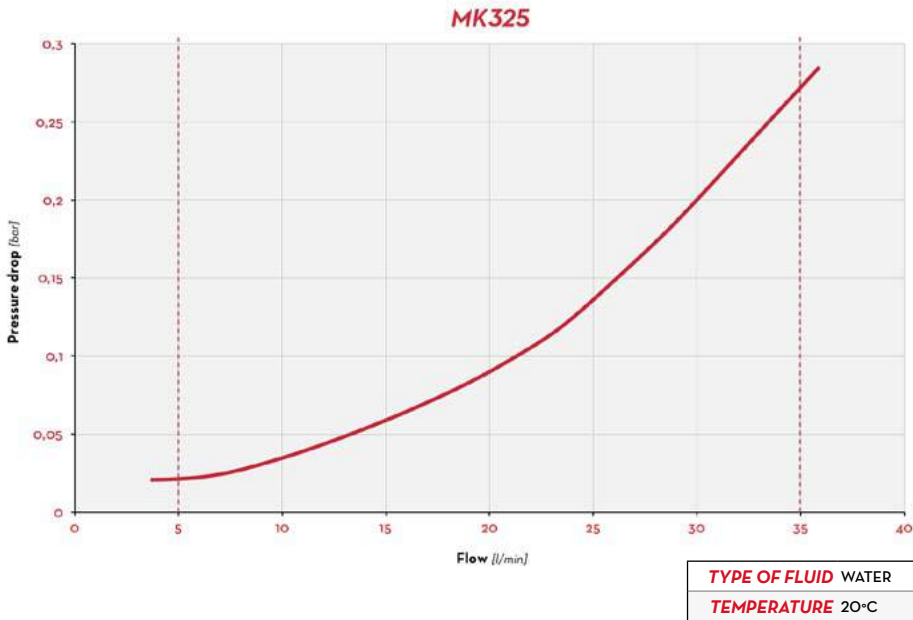

DIMENSIONS

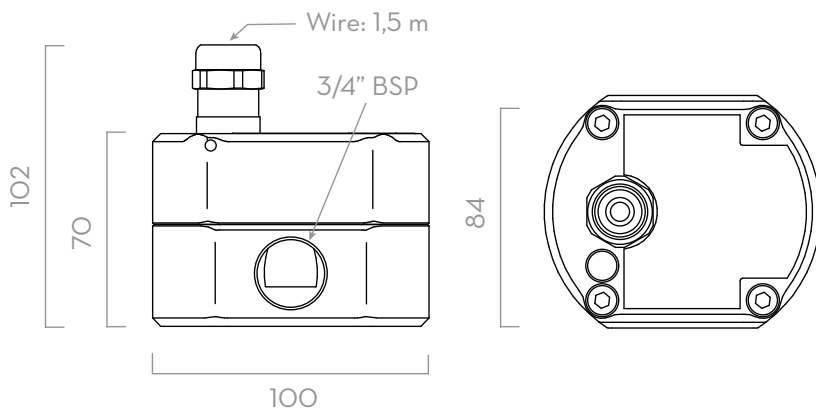

Dimensions expressed in millimeters

IN THE BOX

- MK325 METER
- INSTRUCTIONS WITH CALIBRATION FACTOR
- INSTRUCTION MANUAL

DETAILS



1,5M CABLE LENGTH



ATEX CERTIFIED



PEEK GEAR



BIDIRECTIONAL MEASURING

MATERIALS

- BODY: STAINLESS STEEL
- CABLE BOX: ALLUMINIUM
- GEAR: PEEK
- SEALS: NPR

TECHNICAL DATA

CODE	DESCRIPTION	FLUIDS TYPE	FLOW RATE		PRESSURE		DISPLAY	PULSE OUT (P/L)	
			L/MIN	GPM	BAR	PSI		PULSE VERSION	DISPLAY VERSION
FO0476X00	MK325 METER		5 - 35	1,3 - 8-9,3	20	290	NO	APPROX. 160	NO

OTHER VERSION AVAILABLE ON REQUEST

MK325 METER