



FUEL MANAGEMENT SYSTEMS



DISPENSERS



KITS



PUMPS



METERS



NOZZLES

K700 PULSER

FEATURES

- EASY TO INSTALL AND TO CALIBRATE
- VERSATILE
- HIGH FLOW RATE
- HEAVY DUTY
- INDUSTRIAL APPLICATIONS

The PIUSI K700 PULSER is an oval gear electronic meter with acetal resin gears. This pulse meter easily interfaces with management systems, making it the ideal solution to fit fuel distributors. It is also suitable for tanks and cisterns, loading arms controlling the consumption of fuel in burners or generator sets, besides other applications.

PERFORMANCE

25-250

L/MIN

FLOW RATE

20 BAR

MAX

OPERATING PRESSURE

± 0,5%

ACCURACY

0,2%

REPEATABILITY



K700 PULSER



PACKAGING

| CODE | WEIGHT | | PACKAGING | | |
|------|--------|-----|-----------|------|---------|
| | KG | LBS | MM | INCH | PCS/BOX |

PULSER

| | | | | | |
|-----------|-----|----|-------------|------------|---|
| FOO49800A | 5,5 | 12 | 280X160X140 | 11X6,3X5,5 | 1 |
|-----------|-----|----|-------------|------------|---|



FILTRATION



TANK MONITORING



HOSE REEL



ACCESSORIES



MERCHANDISE



AIR



ANTIFREEZE



AdBlue®



BIODIESEL



DIESEL



FOOD



GASOLINE



GREASE



KEROSENE



OIL



WATER



WINDSCREEN

CHART



IN THE BOX

- K700 PULSER METER
- INSTRUCTION MANUAL

DETAILS



DIMENSIONS

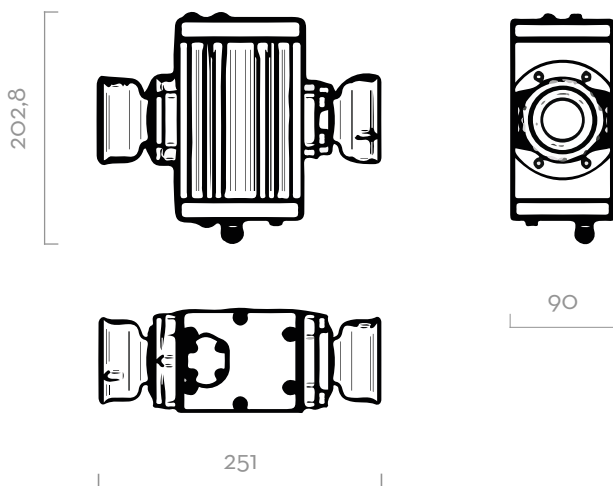

Dimensions expressed in millimeters

MATERIALS

- BODY: ALUMINIUM
- GEARS: TECHNOPOLYMER

TECHNICAL DATA

| CODE | DESCRIPTION | FLUIDS TYPE | FLOW RATE | | PULSER | | PRESSURE | | BATTERY N°2 X 1,5V (INCLUDED) | FLANGE | INLET / OUTLET | INLET FILTER |
|-----------|-------------|-------------|-----------|----------|--------|-----|----------|-----|-------------------------------------|--------|-------------------|-----------------|
| | | | L/MIN | GPM | P/L | GPM | BAR | PSI | | | | |
| FOO49800A | K700 PULSER | A B D O | 25 - 250 | 6,6 - 66 | 14 | 53 | 20 | 300 | NO | YES | 2" BSP | YES |

PULSER

UPON REQUEST AVAILABLE IN NPT VERSION.

K700 PULSER