

LEADER[®]
PUMPS

BLUE DIVER
ADBLUE PUMPS – NEW RANGE

BENEFITS AND UPGRADES - recap

NEW HYDRAULICS: high-efficiency impellers system → *compliance with new MEI standards taking effect on Jan 1st 2024*

MECHANICAL SEAL: it replaces the current lip-seal configuration, improving the system from the point of view of the efficiency and ease of maintenance

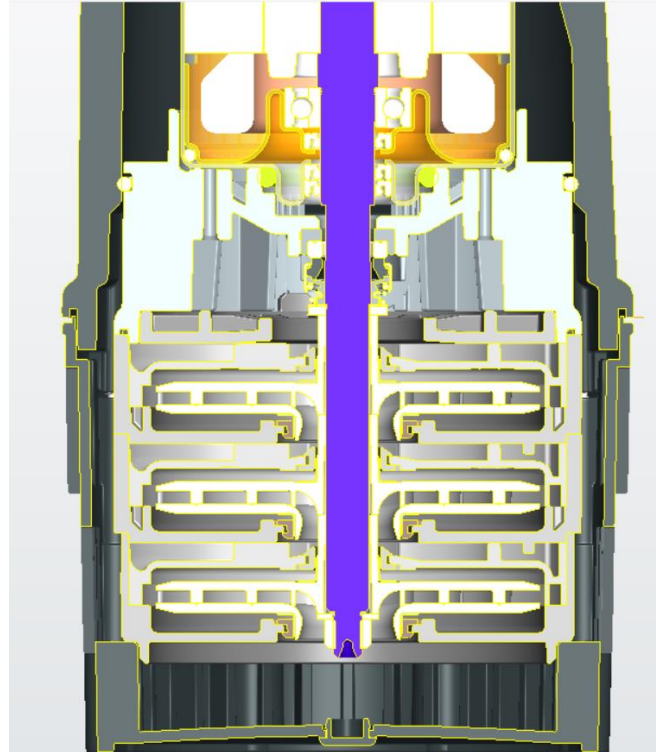

BENEFITS AND UPGRADES - recap

HANDLE: retractable handle to make the transportation/manual lifting of the pumps easy and safe

CAPACITOR: quick and easy replacement of the capacitor directly from the outside, avoiding any further disassembling



SELLING POINTS

EFFICIENCY:

- MEI compliant in advance
- High hydraulic efficiency + high electrical efficiency (low power consumption-energy saving)

EASE OF INSTALLATION:

- New retractable handle

NEW DESIGN:

- Modern, technological design
- «All-black» look for the whole AD BLUE range → distinctive trait from the std models

EASE OF MAINTENANCE:

- Simpler maintenance vs current models
- New «quick&easy» capacitor replacement system

AD BLUE Versions – **Leader** BLUE DIVER

All-black design to maintain a distinctive trait from the standard versions (Leader Ecodiver)



DIMENSIONS - new vs old

Ø 160 mm

Hmax: 453 mm
(model 900)

405 mm
(models 650/500)

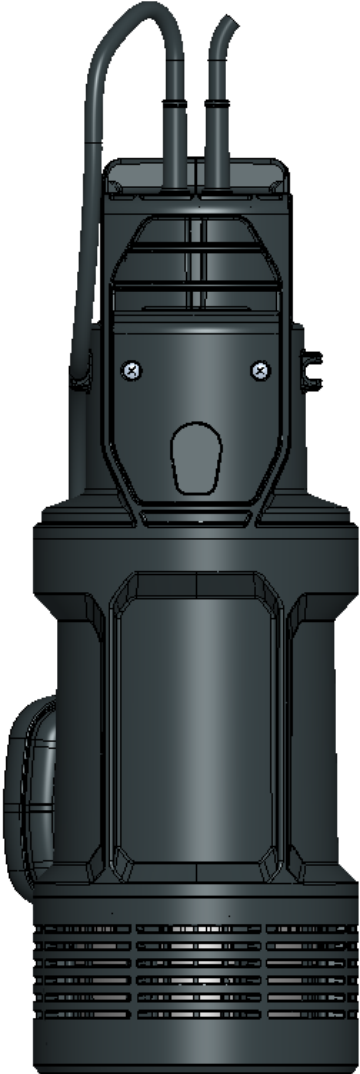

BLUE DIVER
900/650/500



A BLUE DIVER
800/700/600

Ø 150 mm

Hmax: 400 mm
(model 800)

375 mm
(model 700)

350 mm
(model 600)

PERFORMANCE - new vs old

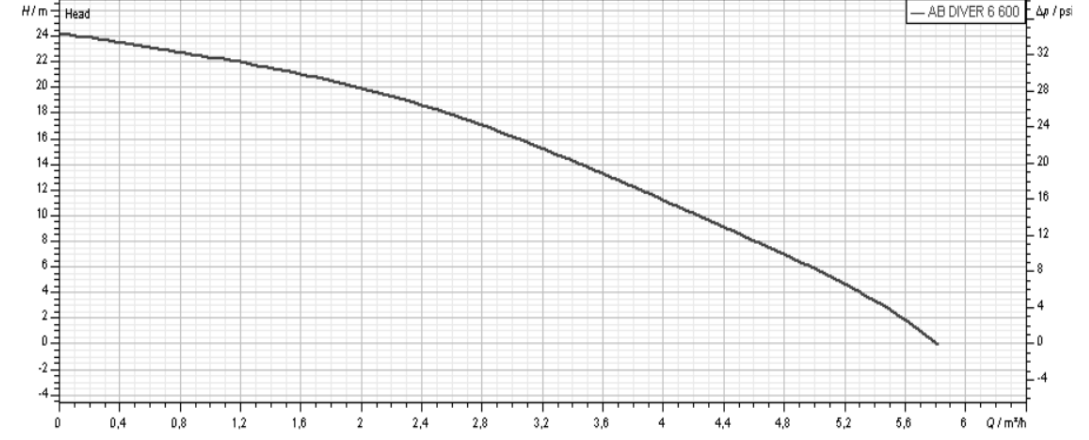
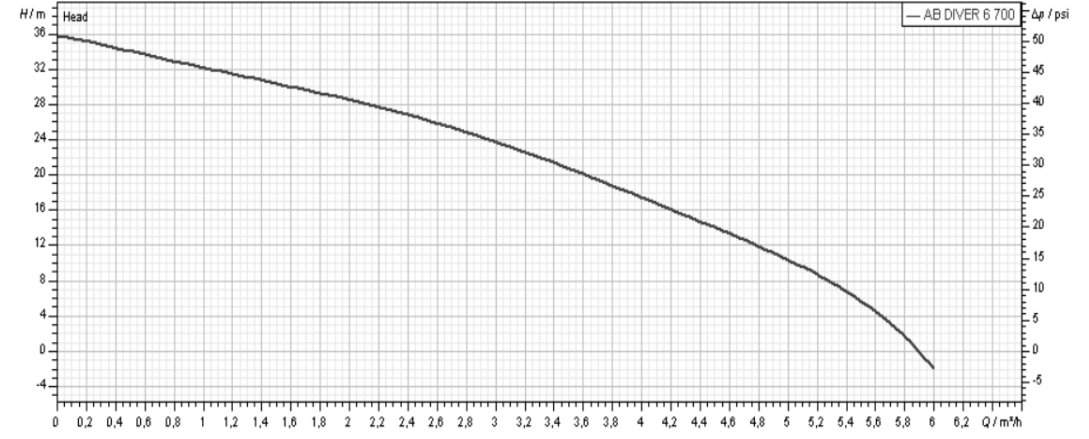
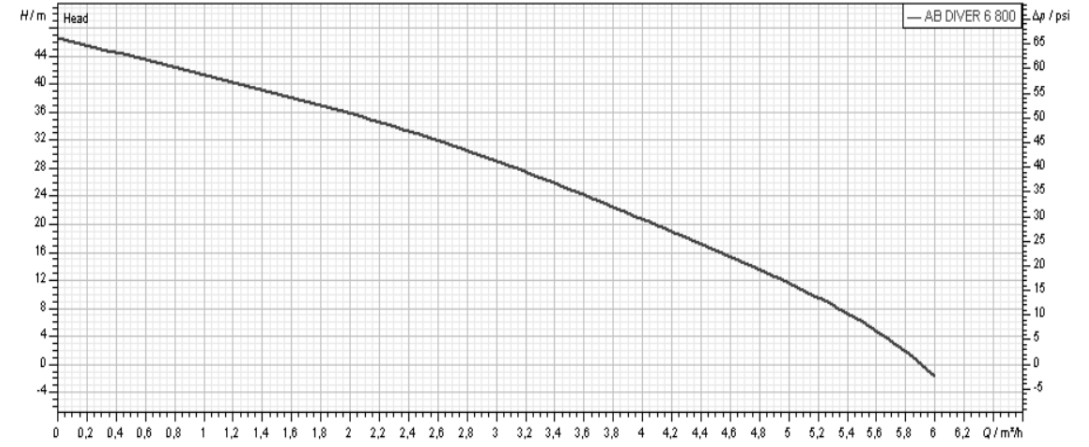
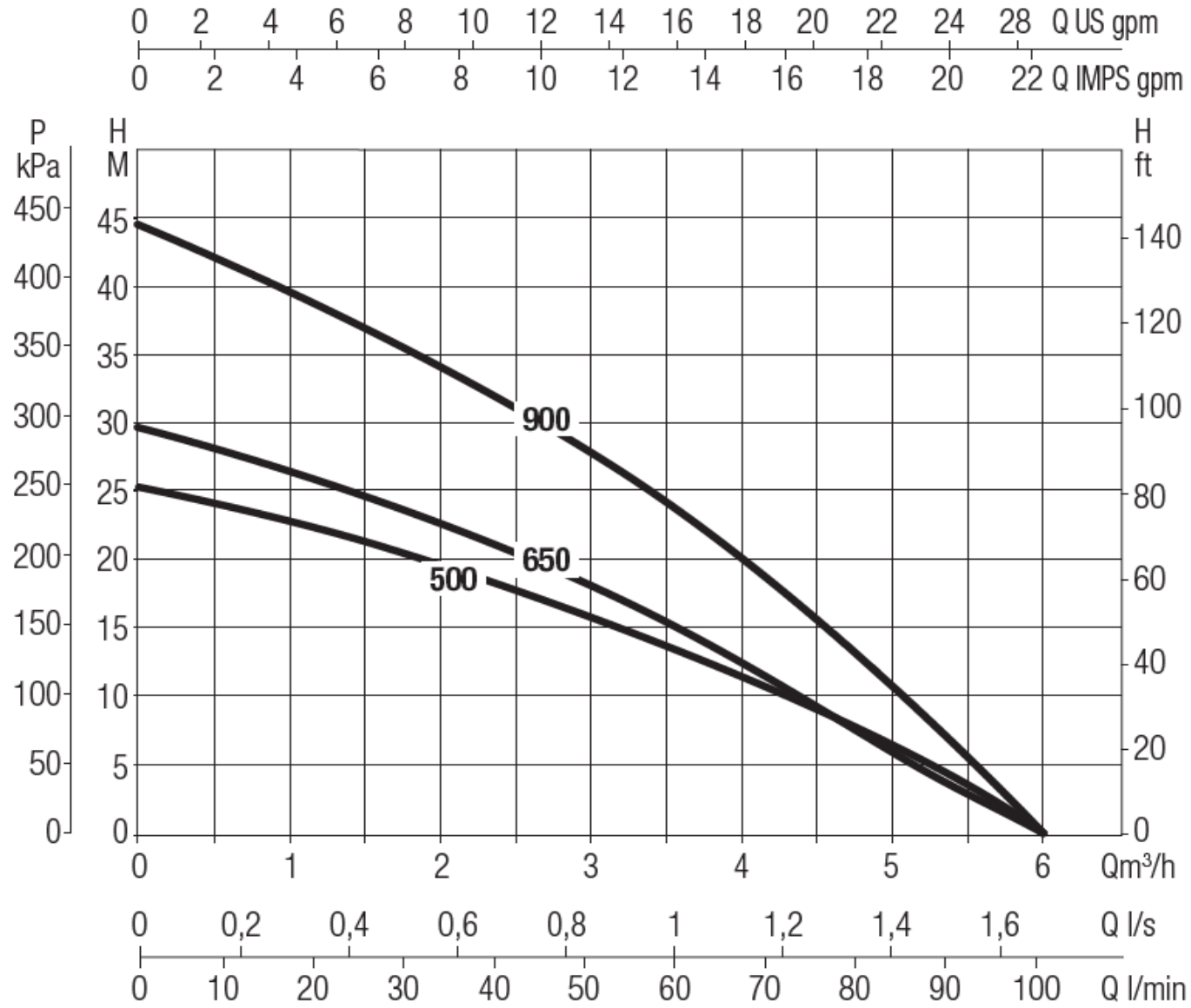

IMPROVEMENTS ON AD BLUE PUMPS

EPDM GASKETS

- Improved durability and chemical resistance

ADDITIONAL NOTES

TWIN MODELS

- «BLUE DIVER TWIN» models **NO LONGER AVAILABLE**
- *The new design's improved efficiency provides the performance to replace the twin models*
- *BLUE DIVER 1000 TWIN → BLUE DIVER 500*

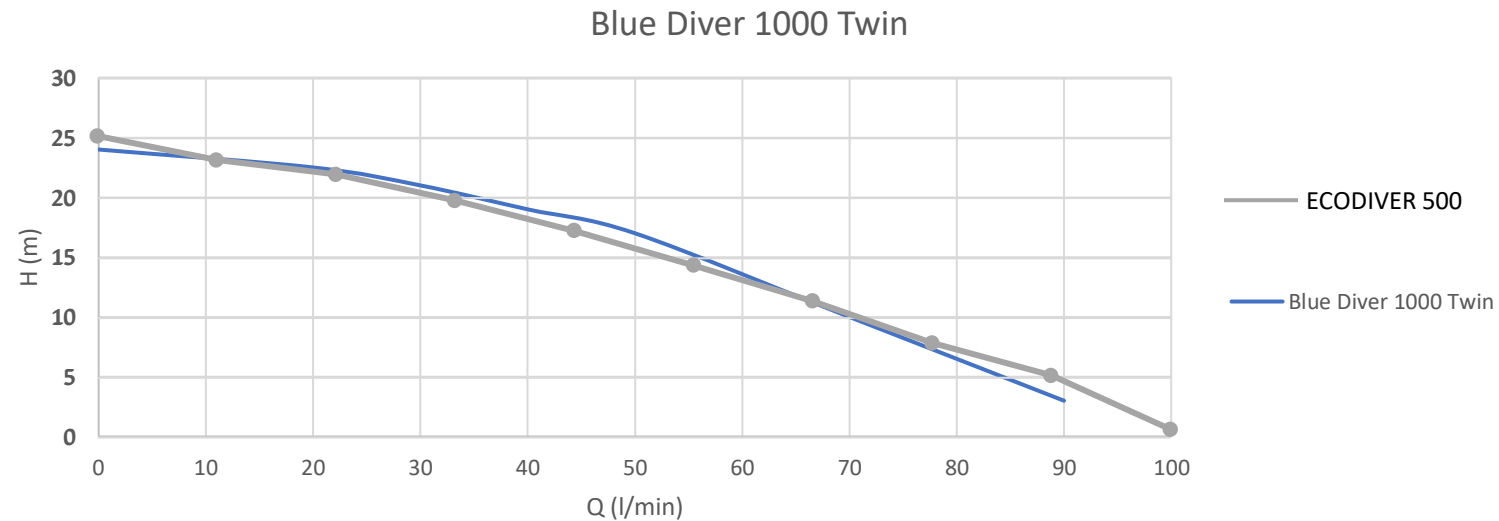

ADDITIONAL NOTES

ATEX MODELS

- «Ex BLUE DIVER» models *NO LONGER AVAILABLE*

AD BLUE USE ONLY