



CAR FILLING



DISPENSERS



PUMPS



METERS



NOZZLE METERS



NOZZLES

SUZZARABLUE PUMP DC

FEATURES

- **READY TO USE**
- **MULTI-PURPOSE PUMP**
- **SELF PRIMING**
- **BUILT-IN BYPASS VALVE**

The Piusi SUZZARABLUE DC PUMP is an electric DC diaphragm pump suitable for transferring AdBlue®. This self-priming pump is equipped with a built-in pressure by-pass.

PERFORMANCE

UP TO

30 L/MIN

FLOW RATE

20 MIN

DUTY CYCLE



SUZZARABLUE PUMP DC



PACKAGING

CODE	WEIGHT		PACKAGING		N. BOXES/EUROPALLET	
	KG	LBS	MM	PCS/BOX		
FO0204080	3,6	7,9	350X180X280	1	60	84
FO0204090	3,6	7,9	350X180X280	1	60	84



FILTRATION



FLUID MONITORING



HOSE REELS



ACCESSORIES



MERCHANDISE



AIR



ANTIFREEZE



AdBlue®



BIODIESEL



DIESEL



FOOD



GASOLINE



GREASE



KEROSENE



OIL



WATER



WINDSCREEN

CHARTS

SUZZARABLU DC

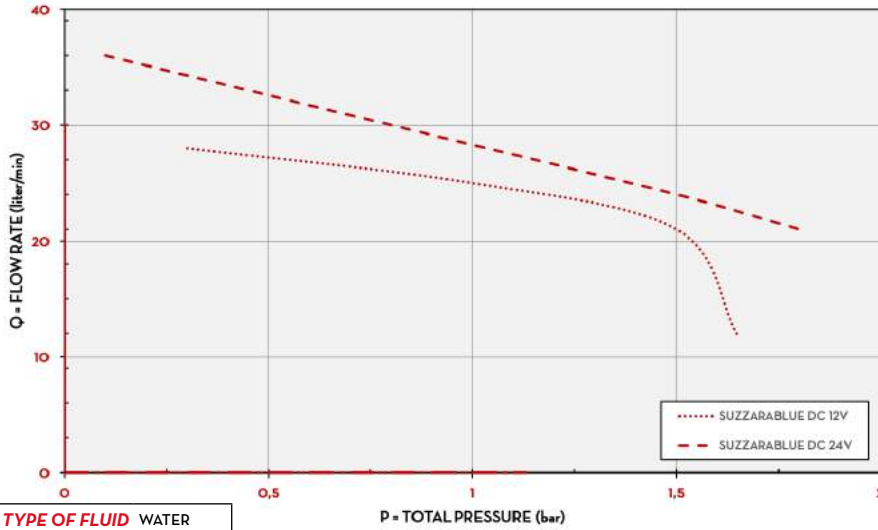

TYPE OF FLUID WATER
 TEMPERATURE 20 °C

IN THE BOX

- SUZZARABLU PUMP
- CLAMPS
- INSTRUCTION MANUAL

DETAILS



ON/OFF SWITCH



CLAMPS

DIMENSIONS

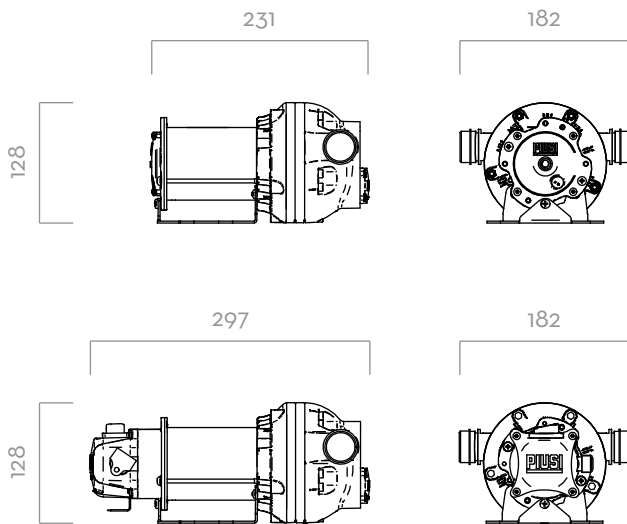

Dimensions expressed in millimeters

MATERIALS

- BODY: POLIPROPILENE
- DIAPHRAGM: POLIPROPILENE

TECHNICAL DATA

CODE	DESCRIPTION	FLUIDS TYPE	FLOW-RATE		VOLTAGE			CABLES	INLET-OUTLET	ON/OFF	
			L/MIN	GPM	AC V/HZ DC VOLT	RPM	POWER WATT				AMP. MAX.
FOO204080	SUZZARABLU DC PUMP 12V		35	9,2	12	2800	260	22	YES	3/4"	YES
FOO204090	SUZZARABLU DC PUMP 24V		35	9,2	24	2800	310	13	YES	3/4"	YES

SUZZARABLU PUMP DC