



CAR FILLING



DISPENSERS



PUMPS



METERS



NOZZLE METERS



NOZZLES

SUZZARABLUE DRUM

FEATURES

- DESIGNED FOR 200 L DRUM
- EASY TO INSTALL
- SUZZARABLUE PUMP

The PIUSI Suzzarablue Drum is the solution for all the AdBlue® drum applications. Its adjustable bracket allows an easy installation on any kind of barrel.

PERFORMANCE

UP TO

32 L/MIN

FLOW RATE

AC V. / Hz

230/50

VOLTAGE

POWER

20 MIN

DUTY CYCLE



SUZZARABLUE DRUM



PACKAGING

CODE	WEIGHT		PACKAGING		
	KG	LBS	MM	INCH	PCS/BOX
FOO20135E	16	35,3	470X370X265	18,3X14,6X10,4	1
FOO201D5C	16	35,3	470X370X265	18,3X14,6X10,4	1
FOO201E5C	16	35,3	470X370X265	18,3X14,6X10,4	1



FILTRATION



FLUID MONITORING



HOSE REELS



ACCESSORIES



MERCHANDISE



AIR



ANTIFREEZE



AdBlue®



BIODIESEL



DIESEL



FOOD



GASOLINE



GREASE



KEROSENE



OIL



WATER



WINDSCREEN

CHARTS

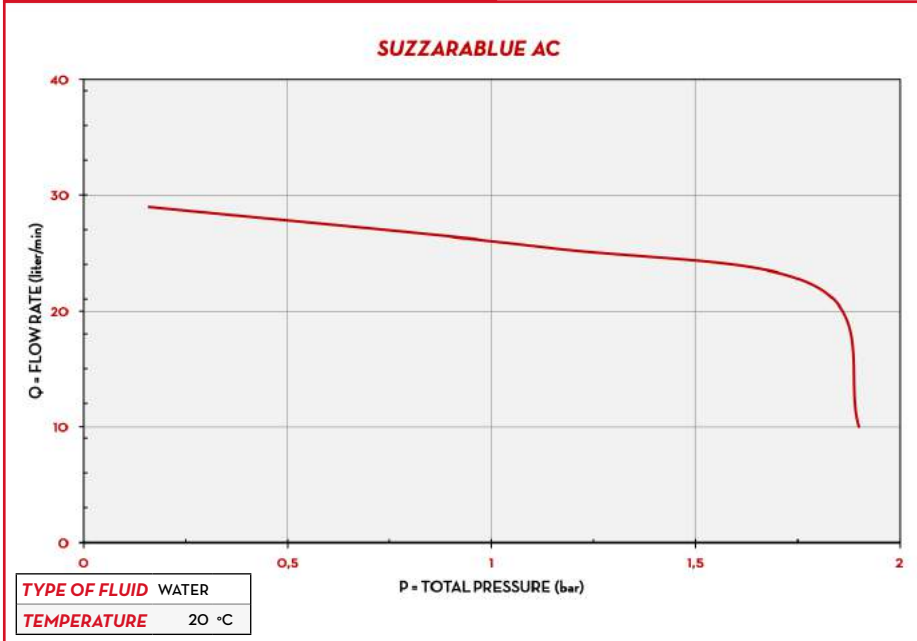

IN THE BOX

- SUZZARBLUE DRUM UNIT
- SB325 / SB325 METER NOZZLE (ON REQUEST)
- AF2 CONNECTOR
- SUCTION PIPE
- DELIVERY HOSE
- INSTRUCTION MANUAL

DETAILS



SUZZARBLUE PUMP AC



SEC/BOTTOM CONNECTION



SUCTION PIPE

DIMENSIONS

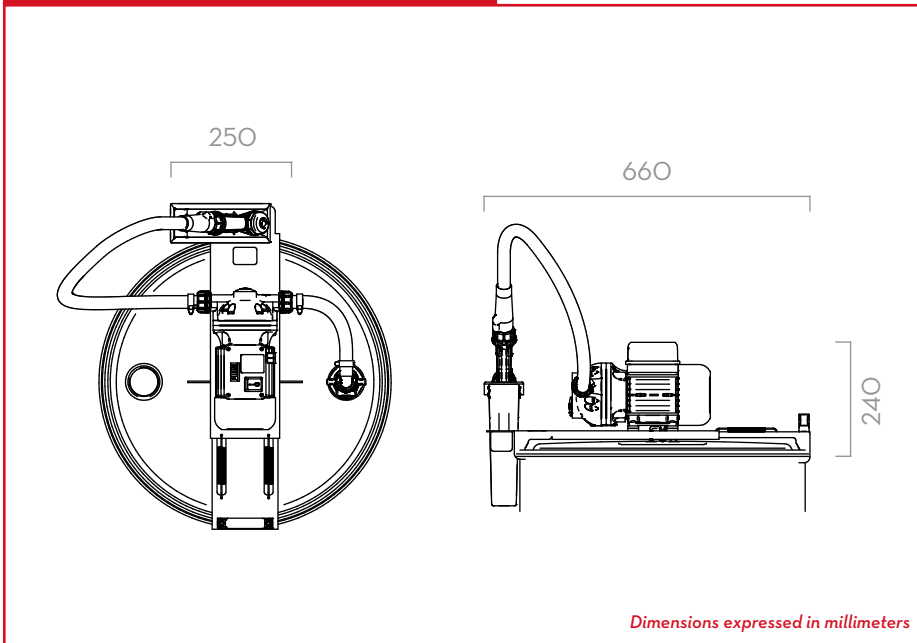

MATERIALS

- **PUMP:**
SUZZARBLUE PUMP AC PAG. 40
- **NOZZLE:**
SB325_X METER PAG. 76
SB325_X PAG. 84
SUZZARBLUE MANUAL NOZZLE PAG. 88

TECHNICAL DATA

CODE	DESCRIPTION	FLUIDS TYPE	FLOW-RATE		VOLTAGE			METER	NOZZLE	SUCTION	HOSE		ON/OFF	
			L/MIN	GPM	AC V/ HZ	DC VOLT	POWER WATT				AMP. MAX.	LENGHT		Ø
FOO20135E	SUZZARBLUE DRUM		32	8,5	230/50		400	495	NO	MAN.	SEC	6 M	3/4"	YES
FOO21D5C	SUZZARBLUE DRUM + SB325_X		32	8,5	230/50		400	495	NO	SB325	SEC	6 M	3/4"	YES
FOO201E5C	SUZZARBLUE DRUM + SB325_X METER		32	8,5	230/50		400	495	NO	SB325	SEC	6 M	3/4"	YES

SUZZARBLUE DRUM