



CAR FILLING



DISPENSERS



PUMPS



METERS



NOZZLE METERS



NOZZLES

MP 190

FEATURES

- IN/OUT INTERCHANGEABLE
- LONG LIFE DIAPHRAGM
- BUILT-IN DIFFUSER
- SUITABLE FOR SUBMERSIBLE INSTALLATIONS
- HEAVY DUTY
- MULTI-PURPOSE PUMP
- STURDY DESIGN

The Piusi MP 190 is a pneumatic multi-purpose AdBlue® diaphragm pump. The sturdy central technopolymer body makes this pump suitable for an heavy duty usage.



PERFORMANCE

UP TO

220 L/MIN

FLOW RATE

MAX CAPACITY

6M

SELF PRIMING

MAX

7 BAR

AIR SUPPLY

PRESSURE

MAX

Ø 4MM

PASSING SOLID

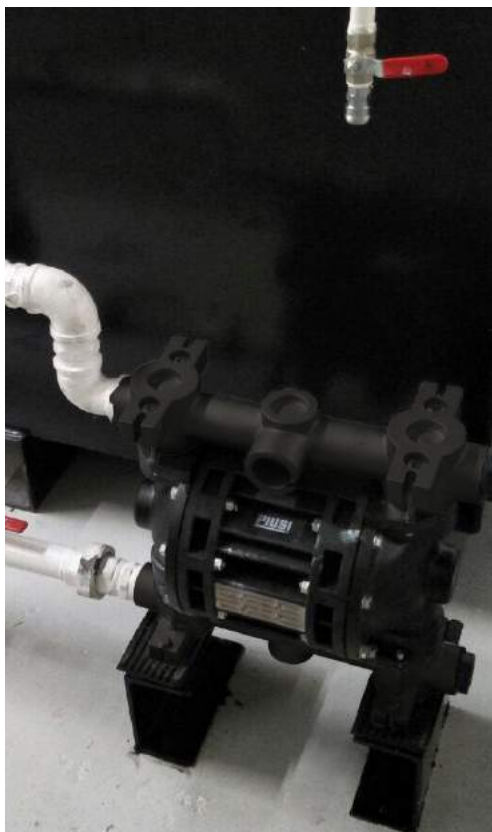

MP190

PACKAGING

CODE	WEIGHT		PACKAGING		
	KG	LBS	MM	INCH	PCS/BOX
FOO208P40	12	26,5	290X470X460	11,4X18,5X18,1	1



FILTRATION



FLUID MONITORING



HOSE REELS



ACCESSORIES



MERCHANDISE



AIR



ANTIFREEZE



AdBlue®



BIODIESEL



DIESEL



FOOD



GASOLINE



GREASE



KEROSENE



OIL



WATER



WINDSCREEN

CHARTS

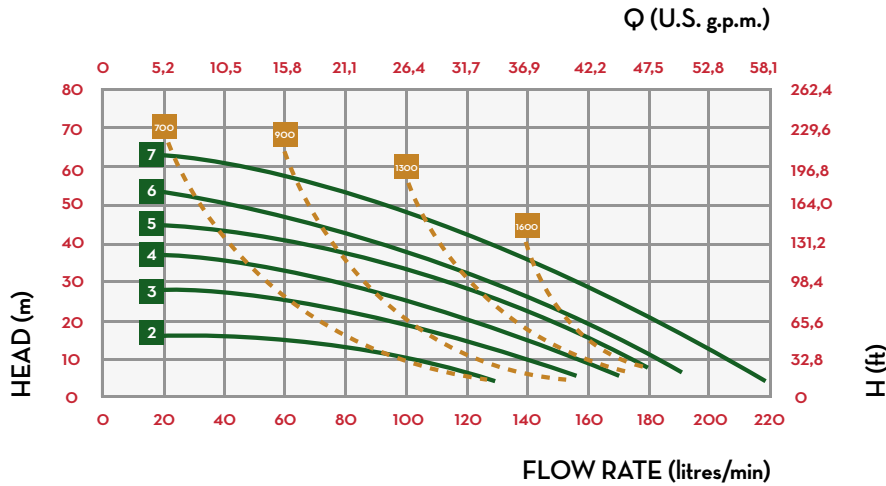

IN THE BOX

- MP PUMP
- INSTRUCTION MANUAL

DETAILS



HEAVY DUTY MATERIALS



TECHNOPOLYMER BODY



STURDY DESIGN

MATERIALS

- BODY: TECHNOPOLYMER
- SIDE PARTS AND COLLECTORS: POLYPROPYLENE
- DIAPHRAGM: EPDM

DIMENSIONS

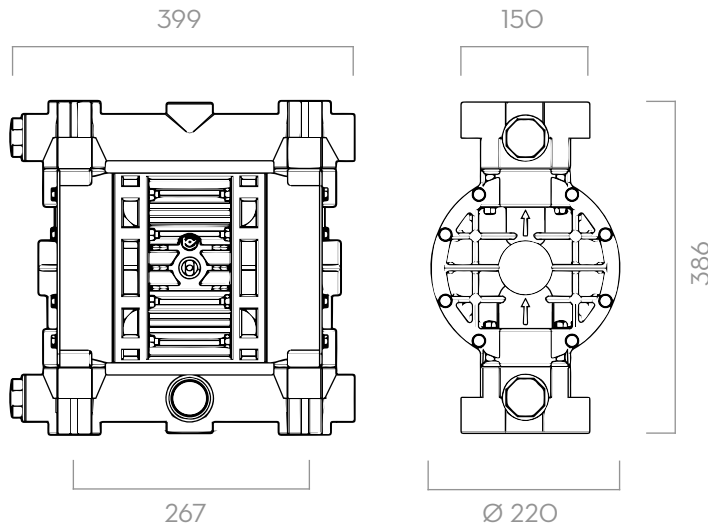

Dimensions expressed in millimeters

TECHNICAL DATA

CODE	DESCRIPTION	FLUIDS TYPE	PUMP BODY	IN / OUT	FLOW RATE L/MIN	MEMBRANE TYPE	DIAPHRAGM AIR SIDE/ FLUID SIDE	BALLS	BALL SEATS*	O-RING*	INTAKE / DELIVERY CONNECTION	AIR CONNECTION	MAX SELF-PRIMING CAPACITY	MAX HEAD**	MAX AIR SUPPLY PRESSURE	MAX Ø OF PASSING SOLID
													M	M	BAR	MM
FOO208P40	PIUSI MP 190		POLYPROPYLENE	1" 1/4" G	220	DOUBLE	PTFE/ HYTREL	PTFE	POLYPROPYLENE	PTFE	G 1/4" F	G 1/2" F	6	70	7	4

(*) ON REQUEST WE CAN PROVIDE MEMBRANES, BALLS, BALL SEATS AND O-RINGS IN DIFFERENT MATERIALS.

(**) THE VALUE DEPENDS ON THE CONFIGURATION OF THE PUMP