

DIRECTFLO® FUNCTION SERIES



DF100 POLYPROPYLENE AND ALUMINIUM DIAPHRAGM PUMPS. 100 L/MIN

551 164 / 551 030

Very compact and reliable diaphragm pumps for medium to large volume transfer (100 l/min max.), dosing, spraying and dispensing a variety of fluids.

POLYPROPYLENE PUMPS have a polypropylene air motor. Typical applications for these pumps are transferring and dispensing of windshield wash and antifreeze solutions, pure windshield wash and AdBlue®/DEF. ATEX approved pumps are available for use in potential explosive environments and with flammable fluids like pure ethanol.

ALUMINIUM PUMPS have an aluminium air motor. Typical applications for these pumps are transferring and dispensing of windshield wash and antifreeze solutions; lubricants and diesel; and waste oil evacuation.

They can be used as stand-alone pumps for transfer applications or as systems pumps in distribution systems that include hose reels.



03

OTHER FLUIDS PUMPS

FLUIDS HANDLED

- Antifreeze and antifreeze solutions
- Windshield wash and wind shield wash solutions
- Pure windshield wash and ethanol
- Detergents
- AdBlue®/DEF
- Lubricants
- Waste oil
- Diesel

MARKETS SERVED

- Service shops
- Car and truck dealers
- In plant
- Agriculture
- Lube trucks
- Mining and construction
- Railroad and mass transit

MODELS						
PART No.	PUMP BODY	DIAPHRAGMS	BALLS	SEATS	OTHER WETTED MATERIAL	APPLICATIONS
551 164	Polypropylene	Hytrel®	Hytrel®	Stainless steel	Viton®	Antifreeze and windshield wash solutions, AdBlue®/DEF
551 162	Conductive Polypropylene	PTFE	PTFE	Stainless steel	Viton®	ATEX pump for pure ethanol, pure windshield wash, detergents
551 010	Aluminium	Hytrel®	Hytrel®	Stainless steel	Viton®	Antifreeze and windshield wash solutions
551 030	Aluminium	Buna-N	Buna-N	Stainless steel	-	Antifreeze solutions, lubricants, diesel, waste oil evacuation and transfer

Tested at room temperature, with water and flooded pump with 800 mm (31.5 inches) height of water above the pump inlet.

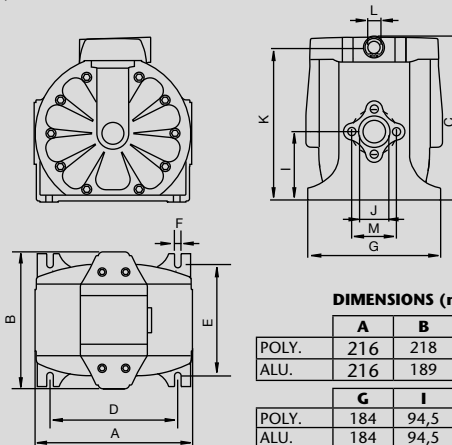
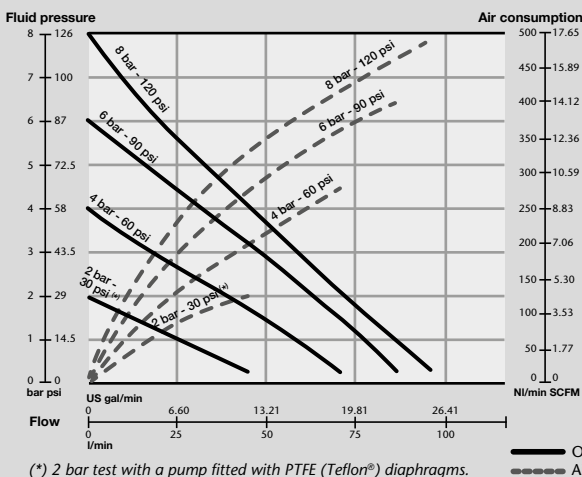

DIMENSIONS (mm)

	A	B	C	D	E	F*
POLY.	216	218	230	175	154	8
ALU.	216	189	227	175	154	9
	G	I	J	K	L	M
POLY.	184	94,5	1" (F)	211,5	3/8" (F)	62
ALU.	184	94,5	1" (F)	210	3/8" (F)	62**

* Diameter of the holes for fasteners in each of the four pump feet.
** Flange connection: 2 bolts - M 5 (41 mm between centres).

(*) 2 bar test with a pump fitted with PTFE (Teflon®) diaphragms.