

556 115

DC20 POLYPROPYLENE DIAPHRAGM PUMP. 20 L/MIN

Very compact and reliable polypropylene diaphragm pump for small volume transfer (20 l/min max.), dosing and spraying a variety of fluids. Polypropylene body and air motor, and PTFE diaphragms and check valve balls for wider chemical compatibility.



03

OTHER FLUIDS PUMPS

### FLUIDS HANDLED

- Antifreeze and antifreeze solutions
- Windshield wash solutions
- Detergents
- AdBlue®/DEF

### MARKETS SERVED

- Service shops
- Car dealers
- In plant
- Agriculture

MODELS						
PART No.	PUMP BODY	DIAPHRAGMS	BALLS	SEATS	OTHER WETTED MATERIAL	APPLICATIONS
556 115	Polypropylene	PTFE	PTFE	Polypropylene	Viton®	Antifreeze and windshield wash solutions, detergents, AdBlue®/DEF

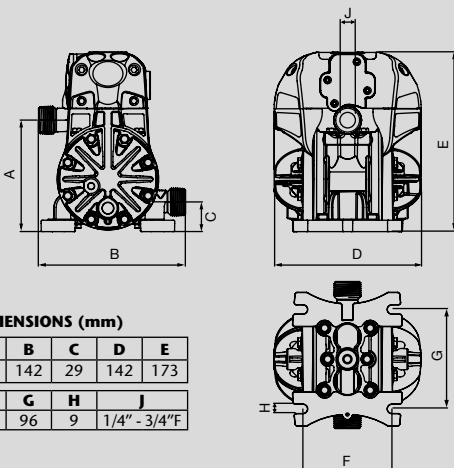

DIMENSIONS (mm)

A	B	C	D	E
108	142	29	142	173
F	G	H	J	
86	96	9	1/4" - 3/4"	

Tested at room temperature, with water and flooded pump with 800 mm (31.5 inches) height of water above the pump inlet.

