

Brochure

CDX



CDX serie

SINGLE IMPELLER CENTRIFUGAL ELECTRIC PUMPS

in AISI 304



Single impeller centrifugal electric pumps with hydraulic parts in AISI 304 stainless steel.

APPLICATIONS

- Domestic pressure boosting
- Small-scale garden irrigation
- Washing
- Treating water
- Cooling towers
- Moving clean water in general

TECHNICAL DETAILS

- Solid hydraulic structure
- Small dimensions

PUMP TECHNICAL DATA

- Maximum working pressure: 8 bar
- Maximum temperature of the liquid:
 - 5°C ÷ +60°C for CDX 70/05-70/07-90/10
 - 5°C ÷ +90°C for the rest of CDX range
 - 5°C ÷ +110°C in the H-HS-HW-HSW-E version
- G1½ suction connection for CDX 200, G1¼ for the rest of the range
- G1 discharge connection
- MEI > 0,1

MOTOR TECHNICAL DATA

- High efficiency IE2 motors starting from 0,75kW
- Self-ventilated 2 pole asynchronous motor
- Class of insulation F
- IP55 Protection degree
- 230V ±10%, 50Hz single phase voltage
- 230/400V ±10%, 50Hz three phase voltage
- Permanent capacitor inserted and thermo-amperometric protection with automatic rearm incorporated for the single phase motor
- Protection under user's responsibility for the three phase version

MATERIALS

- Pump casing, impeller, diffuser and casing cover in AISI 304
- Shaft in AISI 303 (part in contact with the liquid)
- Bracket and motor frame in aluminium
- Mechanical seal in:
 - Ceramic/Carbon/NBR (standard)
 - Ceramic/Carbon/FPM (H version)
 - SiC/SiC/FPM (HS version)
 - Tungsten Carbide/Tungsten Carbide/FPM (HW version)
 - SiC/Tungsten Carbide/FPM (HSW version)
 - Ceramic/Graphite/EPDM (E version)
 - Tungsten Carbide/Special Carbon/EPDM (U3CEGG version)

CONTROL PANELS

- 1EPBH

ACCESSORIES (On request)

- 5 litre 10 bar ¾ EPDM vessel
- 24 litre 8 bar 1" EPDM vessel
- 24 litre 10 bar 1" EPDM vessel
- PVC 5m key float with counter-weight
- PVC 10m key float with counter-weight
- SQUARE-D FSG-2 1.4÷4.6 bar G¼ F pressure switch
- FYG-22 2.8÷7 bar G¼ F pressure switch
- Presscomfort - Pressure regulator
- Press•o•Matic - Variable speed control system (single phase 230V±10% - power supply three phase 220V output - maximum motor power 2.2 kW - 3 HP)

PERFORMANCE RANGE (according to ISO 9906 Attachment A)

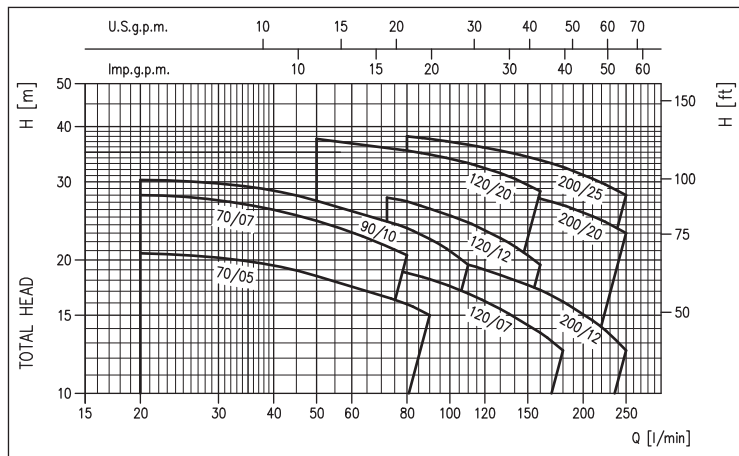

IDENTIFICATION CODE

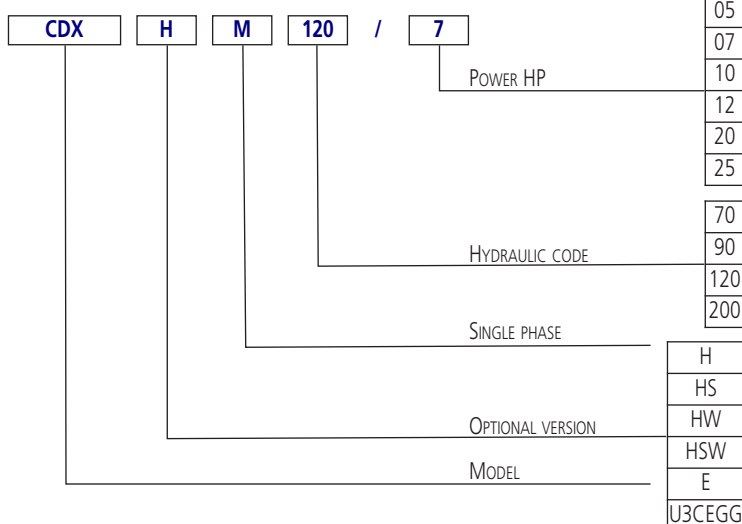

SINGLE IMPELLER CENTRIFUGAL ELECTRIC PUMPS in AISI 304

PERFORMANCE CURVES CDX 70 series

(according to ISO 9906 Attachment A)

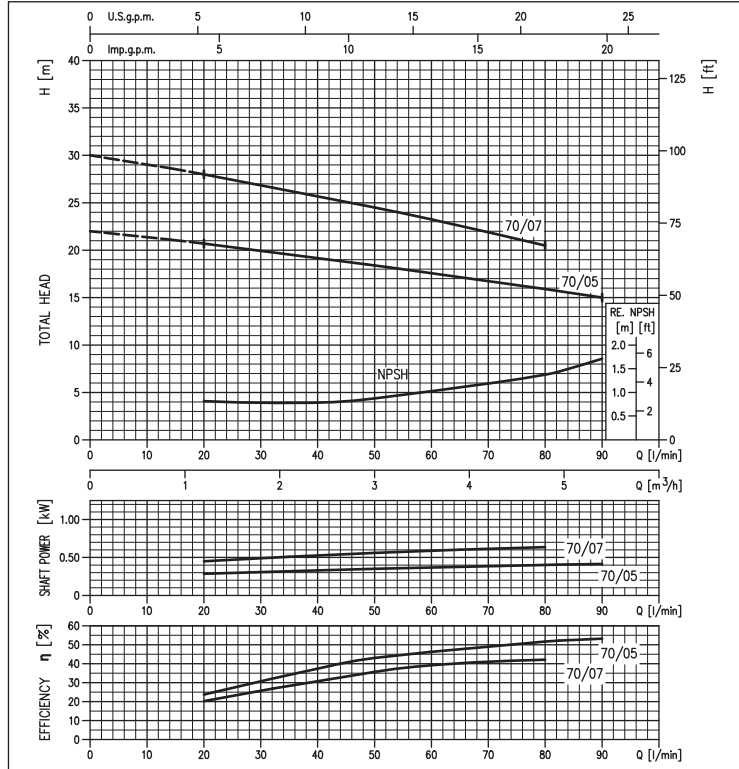

PERFORMANCE CURVES CDX 90 series

(according to ISO 9906 Attachment A)

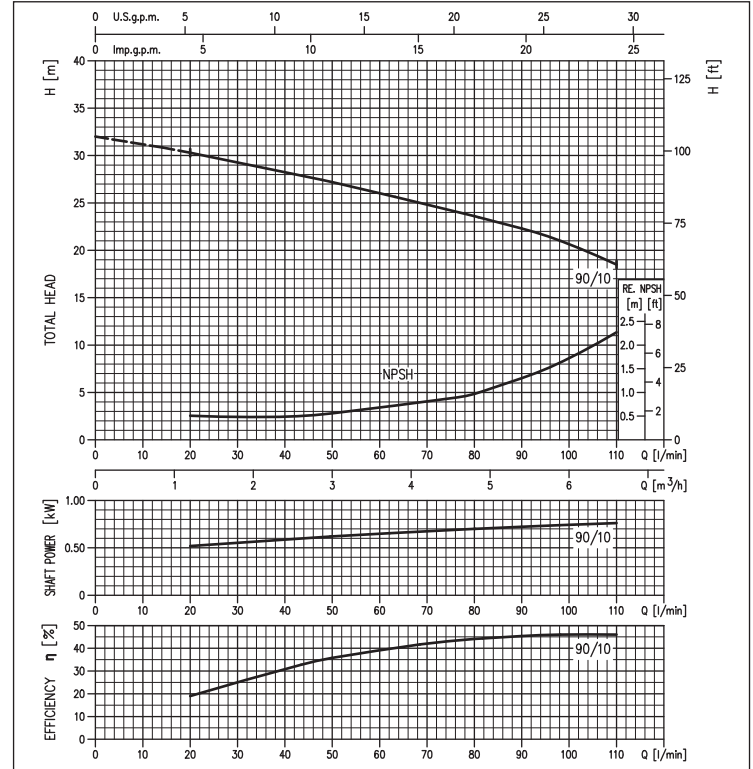

PERFORMANCE CURVES CDX 120 series

(according to ISO 9906 Attachment A)

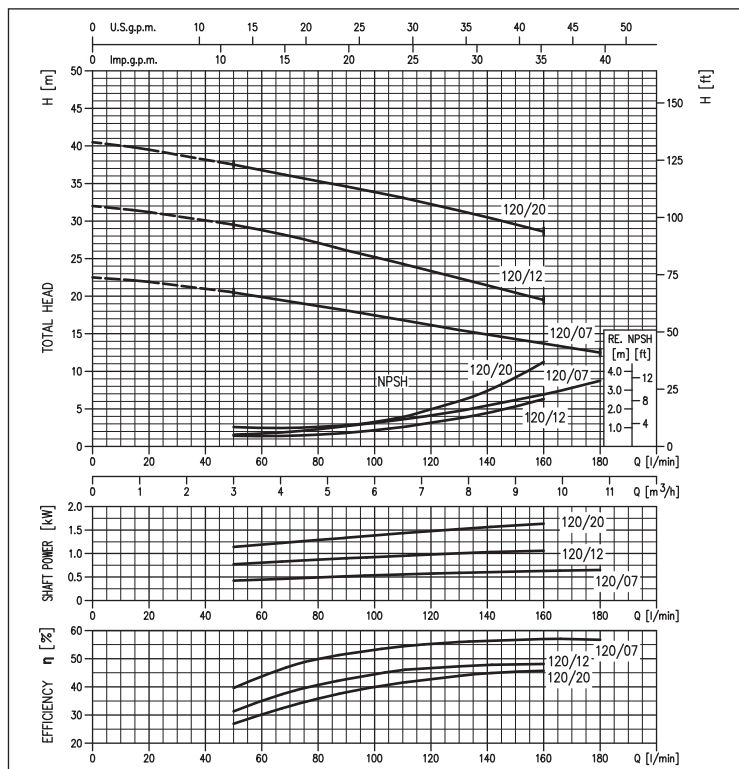

PERFORMANCE CURVES CDX 200 series

(according to ISO 9906 Attachment A)

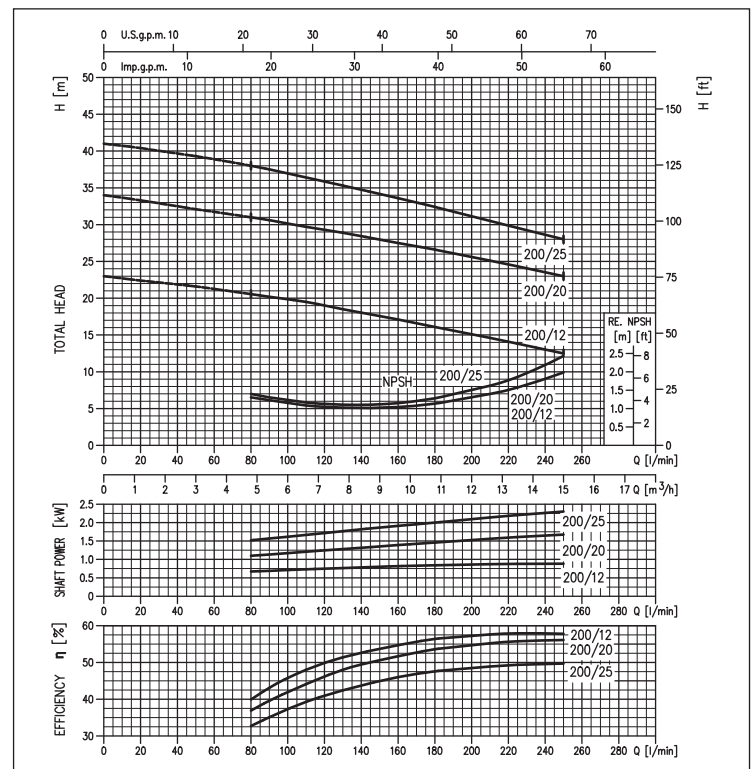

SINGLE IMPELLER CENTRIFUGAL ELECTRIC PUMPS

in AISI 304

PERFORMANCE TABLE

Single phase 230V	Model Three phase 230/400V	P ₂		Q=Flow rate										
		[HP]	[kW]	l/min	20	50	80	90	110	130	160	180	210	250
				m ³ /h	1,2	3	4,8	5,4	6,6	7,8	9,6	10,8	12,6	15,0
				H=Head [m]										
CDXM 70/05	CDX 70/05	0,5	0,37	20,7	18,4	15,9	15,0	-	-	-	-	-	-	-
CDXM 70/07	CDX 70/07	0,8	0,55	28,0	24,5	20,5	-	-	-	-	-	-	-	-
CDXM 90/10	CDX 90/10	1	0,75	30,3	27,2	23,6	22,3	19,5	-	-	-	-	-	-
CDXM 120/07	CDX 120/07	0,8	0,55	-	20,5	18,7	18,1	16,8	15,5	13,7	12,5	-	-	-
CDXM 120/12	CDX 120/12	1,2	0,9	-	29,5	27,1	26,1	24,3	22,4	19,5	-	-	-	-
CDXM 120/20	CDX 120/20	2	1,5	-	37,5	35,3	34,6	33,1	31,4	28,6	-	-	-	-
CDXM 200/12	CDX 200/12	1,2	0,9	-	-	20,7	20,2	19,5	18,5	17,1	16,1	14,6	12,5	-
CDXM 200/20	CDX 200/20	2	1,5	-	-	31,0	30,6	29,7	28,9	27,5	26,6	25,1	23,0	-
-	CDX 200/25	2,5	1,8	-	-	38,0	37,5	36,4	35,3	33,6	32,4	30,5	28,0	-

DIMENSIONS

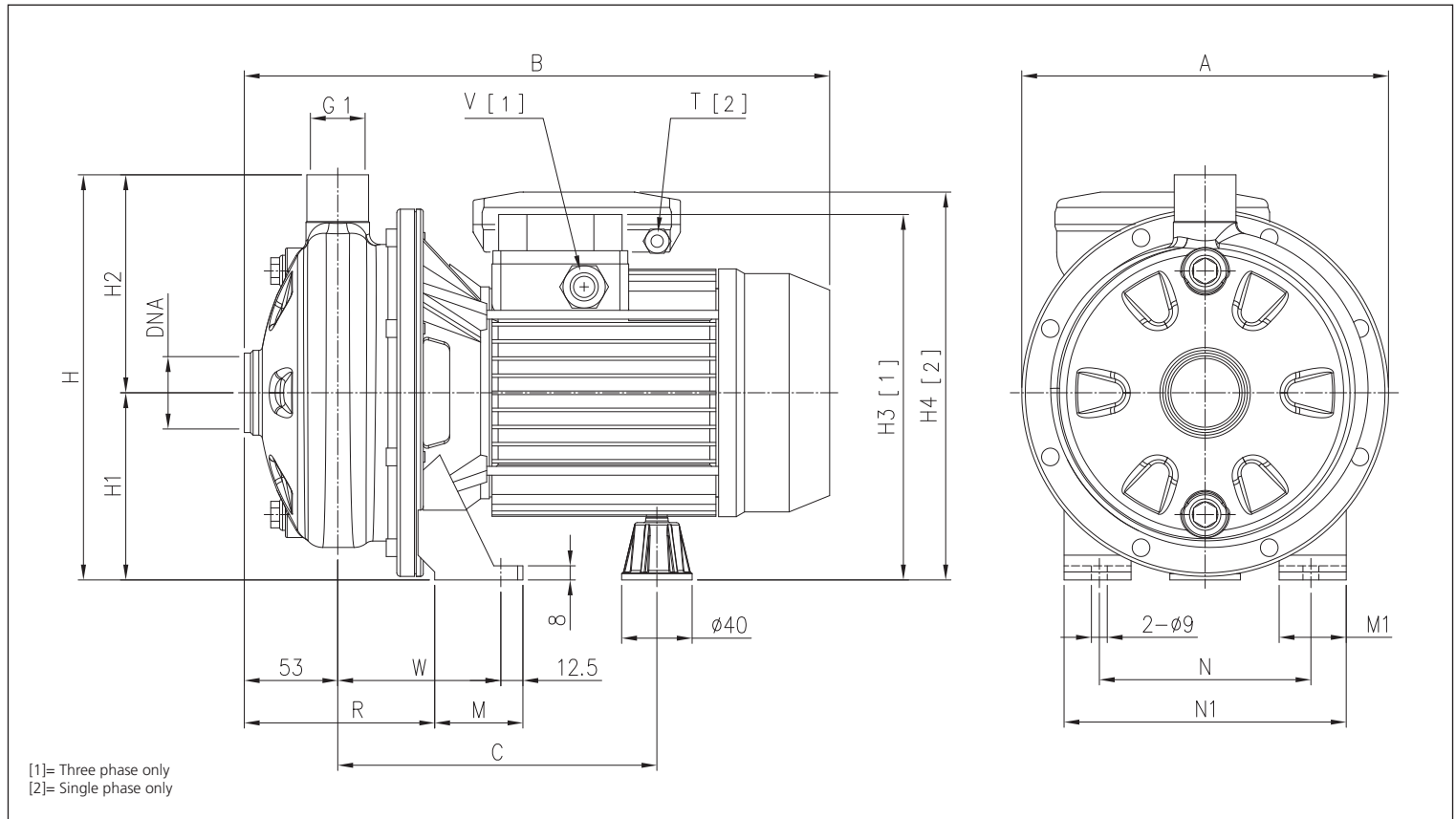

DIMENSIONAL TABLE

Model	Dimensions [mm]																Weight [kg]			
	A	B [2]	B [1]	C	H	H1	H2	H3 [1]	H4 [2]	M	M1	N	N1	R	T [2]	V [1]	W	DNA	[2]	[1]
CDX(M) 70/05	208	321	320	181	229,5	106	123,5	207	216	50	38	120	160	108	PG11	PG11	92,5	G1 ¼	8,3	8,3
CDX(M) 70/07	208	321	320	181	229,5	106	123,5	207	216	50	38	120	160	108	PG11	PG11	92,5	G1 ¼	9,8	9,7
CDX(M) 90/10	208	321	320	181	229,5	106	123,5	207	216	50	38	120	160	108	PG11	PG11	92,5	G1 ¼	11,0	11,0
CDX(M) 120/07	208	321	320	181	229,5	106	123,5	207	216	50	38	120	160	108	PG11	PG11	92,5	G1 ¼	9,6	9,5
CDX(M) 120/12	208	321	332	181	229,5	106	123,5	207	235	50	38	120	160	108	PG11	PG11	92,5	G1 ¼	11,8	12,4
CDX(M) 120/20	232	346,5	359	198,5	250	118	132	237	248,5	55	40	140	180	105,5	PG13,5	PG11	95	G1 ¼	16,5	17,2
CDX(M) 200/12	208	321	332	181	229,5	106	123,5	207	235	50	38	120	160	108	PG13,5	PG11	92,5	G1 ½	11,4	12,2
CDX(M) 200/20	208	346,5	359	198,5	229,5	106	123,5	225	236,5	55	40	140	180	105,5	PG13,5	PG11	95	G1 ½	15,3	16,1
CDX 200/25	232	-	359	198,5	250	118	132	237	-	55	40	140	180	105,5	-	PG11	95	G1 ½	-	15,9

[1]= Three phase only
[2]= Single phase only

SINGLE IMPELLER CENTRIFUGAL ELECTRIC PUMPS

in AISI 304

SECTIONAL VIEW

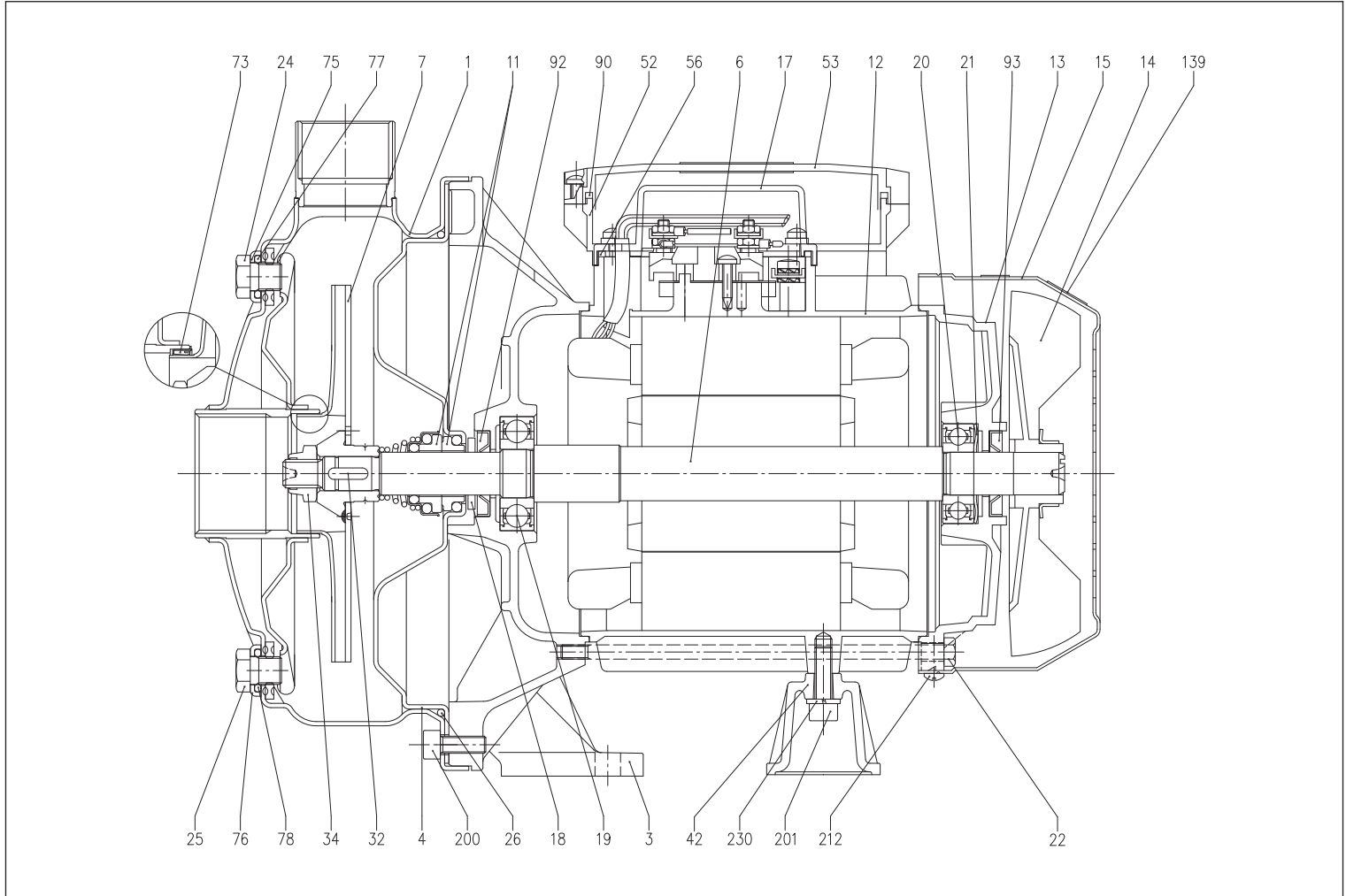

MATERIALS TABLE

Ref.	Name	Materials	Ref.	Name	Materials
1	Pump casing	EN 1.4301 (AISI 304)	25	Plug	AISI 303
3	Motor bracket	Aluminium	26	O-Ring [3]	NBR
4	Casing cover	EN 1.4301 (AISI 304)	32	Key	AISI 316
6	Shaft	AISI 303 Part in contact with the liquid	34	Impeller nut	EN 1.4301 (AISI 304)
7	Impeller	EN 1.4301 (AISI 304)	42	Motor support	Aluminium
11	Mechanical seal [3]	Ceramic/Carbon/NBR	52	Terminal box [2]	ABS
12	Motor frame	-	53	Terminal box cover [2]	ABS
13	Motor cover	Aluminium	56	Terminal box cover gasket	NBR
14	Fan	PA	73	Casing ring [4]	EN 1.4301 (AISI 304)
15	Fan cover	Galvanised Fe P04	75	Washer	EN 1.4301 (AISI 304)
16	Terminal box	-	76	Washer	EN 1.4301 (AISI 304)
17	Terminal box cover [1]	Aluminium	77	O-Ring [3]	NBR
18	Splash ring	NBR	78	O-Ring [3]	NBR
19	Bearing (pump side)	-	90	Gasket [2]	NBR
20	Bearing (motor side)	-	92	Seal ring	-
21	Adjusting ring	Steel C70	93	Seal ring	-
22	Tie-rod	Galvanised Fe 42	110	Motorprotector [2]	-
23	Capacitor [2]	-	200	Screw (pump body)	Stainless steel A2 UNI7323
24	Plug	AISI 303			

[1]= Three phase only [2]= Single phase only

[3]= FPM for CDXH, CDXHS, CDXHW, CDXHSW, EPDM for CDE

[4]= NBR for CDX 70/05, 70/07, 90/10, FPM for CDX H-HS-HW-HSW 70/05, 70/07, 90/10

SINGLE IMPELLER CENTRIFUGAL ELECTRIC PUMPS

in AISI 304

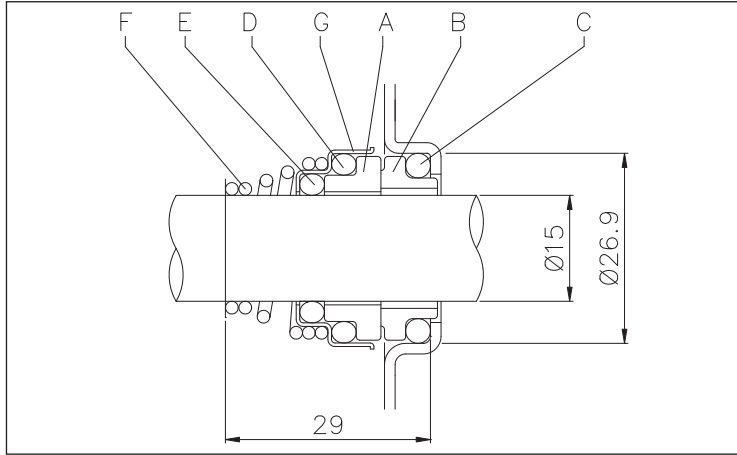

MATERIALS TABLE

Ref.	Name	Materials
A	Rotating part	Ceramic
B	Fixed part	Carbon
C	O-Ring	NBR
D	O-Ring	NBR
E	O-Ring	NBR
F	Spring	AISI 316
G	Structure/frame	AISI 304

SPECIAL MECHANICAL SEALS (on request)

Ref.	Name	Materials					
		H version	HS version	HW version	HSW version	E version	U3CEGG version
A	Rotating part	Ceramic	SiC	Tungsten Carbide	SiC	Ceramic	Tungsten Carbide
B	Fixed part	Carbon	SiC	Tungsten Carbide	Tungsten Carbide	Carbon	Special Carbon
C	O-Ring	FPM	FPM	FPM	FPM	EPDM	EPDM
D	O-Ring	FPM	FPM	FPM	FPM	EPDM	EPDM
E	O-Ring	FPM	FPM	FPM	FPM	EPDM	EPDM
F	Spring	AISI 316	AISI 316	AISI 316	AISI 316	AISI 316	AISI 316
G	Structure/frame	AISI 304	AISI 316	AISI 316	AISI 316	AISI 316	AISI 316

ELECTRIC DATA TABLE

Model	Single phase 230V	Three phase 230/400V	P ₂		Efficiency		Capacitor		Efficiency (%)			P ₁		Absorbed Current [A]		
			[HP]	[kW]	Single phase	Three phase	Single phase	Three phase	50%	75%	100%	Single phase	Three phase	Single phase	Three phase	
					µF	V _c	η %	η %	η %	[kW]	[kW]	230V	230V	400V		
CDXM 70/05	CDX 70/05	0,5	0,37	-	-	12,5	450	-	-	-	0,75	0,68	3,4	2,4	1,4	
CDXM 70/07	CDX 70/07	0,75	0,55	-	-	16	450	-	-	-	1,1	1,0	5,0	3,5	2,0	
CDXM 90/10	CDX 90/10	1	0,75	-	IE2	20	450	77,2	80,9	81,3	1,2	1,05	5,6	3,3	1,9	
CDXM 120/07	CDX 120/07	0,75	0,55	-	IE2	16	450	-	-	-	1,0	1,0	4,6	3,2	1,85	
CDXM 120/12	CDX 120/12	1,2	0,9	-	IE2	31,5	450	79,0	81,7	81,6	1,6	1,45	6,9	4,5	2,6	
CDXM 120/20	CDX 120/20	2	1,5	-	IE2	40	450	80,3	83,4	83,8	2,1	2,09	9,3	7,0	4,0	
CDXM 200/12	CDX 200/12	1,2	0,9	-	IE2	31,5	450	79,0	81,7	81,6	1,4	1,35	6,3	4,3	2,5	
CDXM 200/20	CDX 200/20	2	1,5	-	IE2	40	450	80,3	83,4	83,8	2,3	2,22	10,2	7,4	4,3	
-	CDX 200/25	2,5	1,8	-	IE2	-	-	83,0	84,4	83,8	-	2,87	-	8,7	5,0	

NOISE DATA TABLE

Model	Single phase 230V	Three phase 230/400V	P ₂		L _{pA} - dB(A)*
			[HP]	[kW]	
CDXM 70/05	CDX 70/05	0,5	0,37		61
CDXM 70/07	CDX 70/07	0,75	0,55		62
CDXM 90/10	CDX 90/10	1	0,75		62
CDXM 120/07	CDX 120/07	0,75	0,55		62
CDXM 120/12	CDX 120/12	1,2	0,9		62
CDXM 120/20	CDX 120/20	2	1,5		64
CDXM 200/12	CDX 200/12	1,2	0,9		62
CDXM 200/20	CDX 200/20	2	1,5		64
-	CDX 200/25	2,5	1,8		65

* Mean value of several measures at 1m distance around the pump.
Tolerance ± 2.5 dB.

