

Rev.	Description	Date	Approved
0	ISSUED	25/03/2020	DC

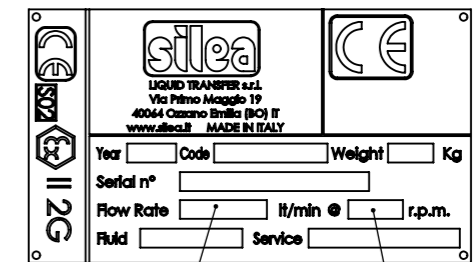
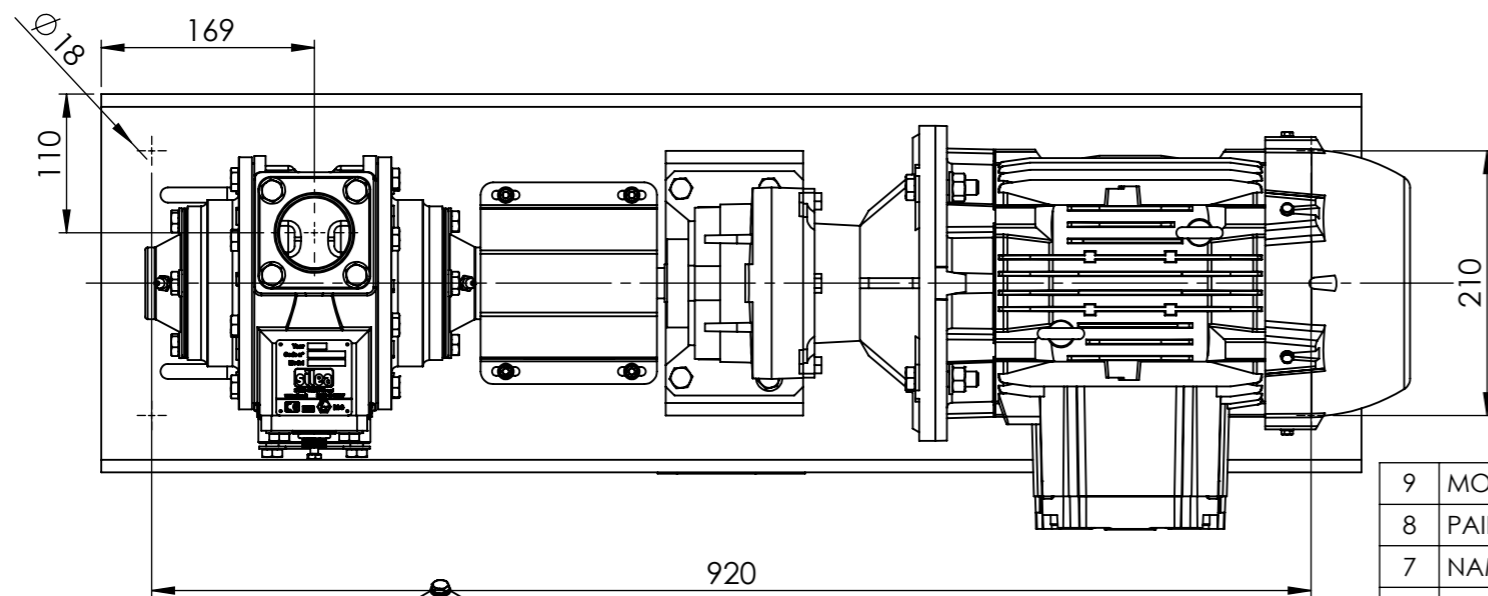
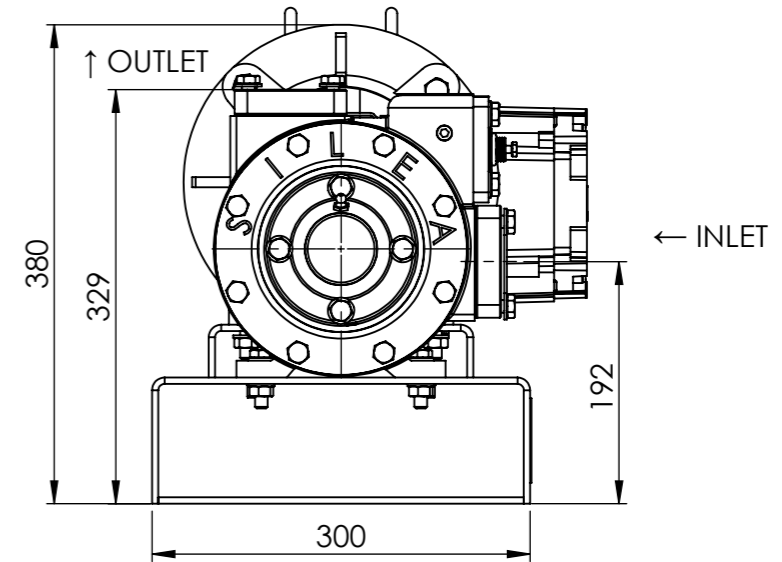
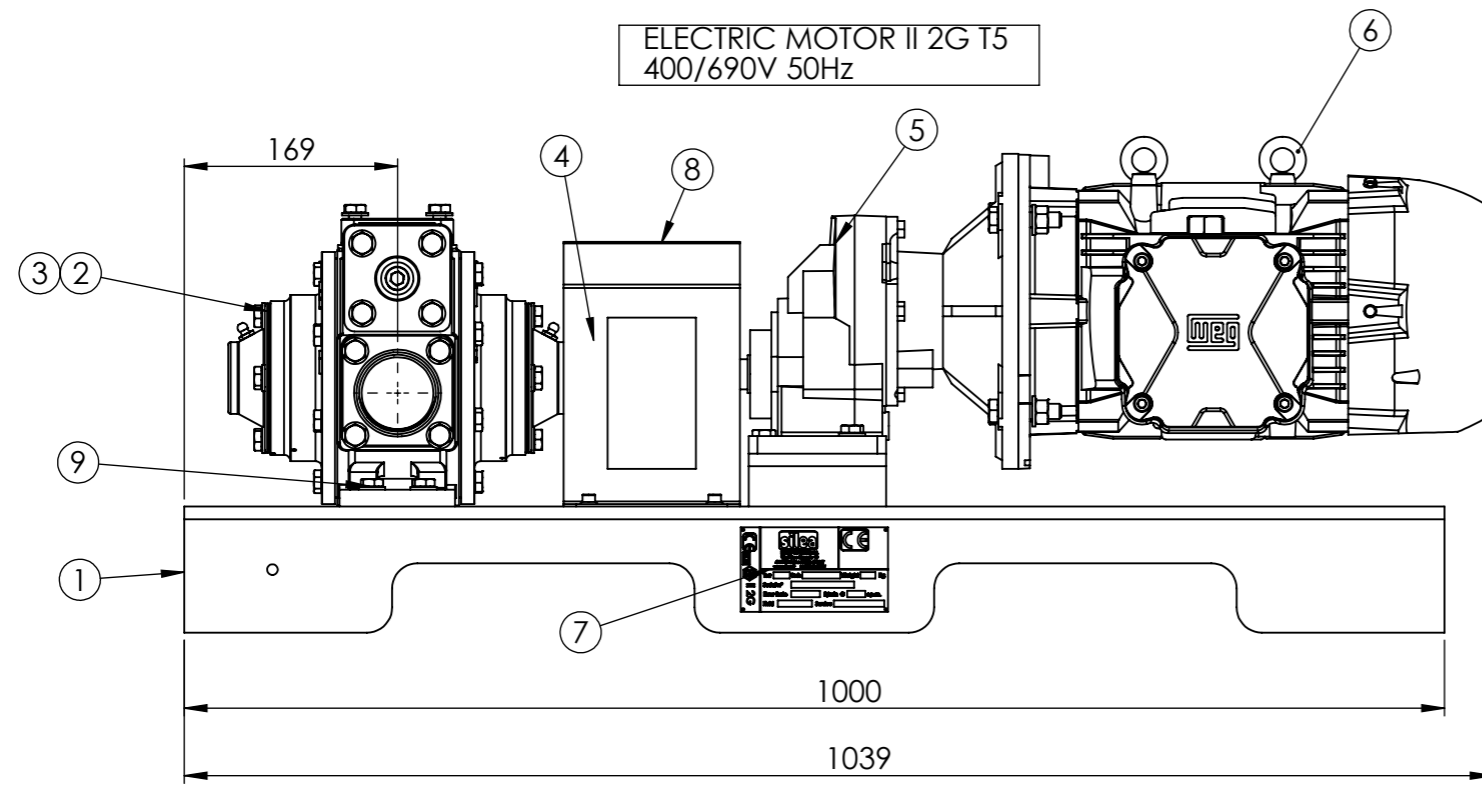

150 lt/min / 450 rpm

9	MOUNTING KIT	1056-AV1	1	0.8	VARIOUS
8	PAINTED CARTER JOINT EPOX RAL2008	1056-0403001	1	1.2	C.S.
7	NAMEPLATE	2299-0000061	1	0.02	ALUMINIUM
6	3Hp ELECTRIC MOTOR B5 4P II2GD	0176-0822008	1	20.000	CAST IRON
5	GEARBOX	0176-H051M400	1	13	CAST IRON
4	SHAFT AXIAL COUPLING	0195-GE2RP	1	2,1	CAST IRON
3	2" SQUARE FLANGE	1052-0001013	2	0.7	C.S.
2	VOLUMETRIC PUMP 2" C - LEFT HAND	10520101E	1	31	CAST IRON
1	BASE SUPPORT PUMP 2" - 2 1/2"	1056-BER2	1	20.0	C.S.
Pos	Description	Code	Q.ty	Wt	Material

Remarks  
This document is the property of Silea L.T. S.r.l. All duplication, partial or complete, should not be made without written approval

Dimension without tolerance figures  
toleranze particolare UNI EN ISO 8015:2011 tolleranze generali UNI EN ISO 22768-1:1996 - mK

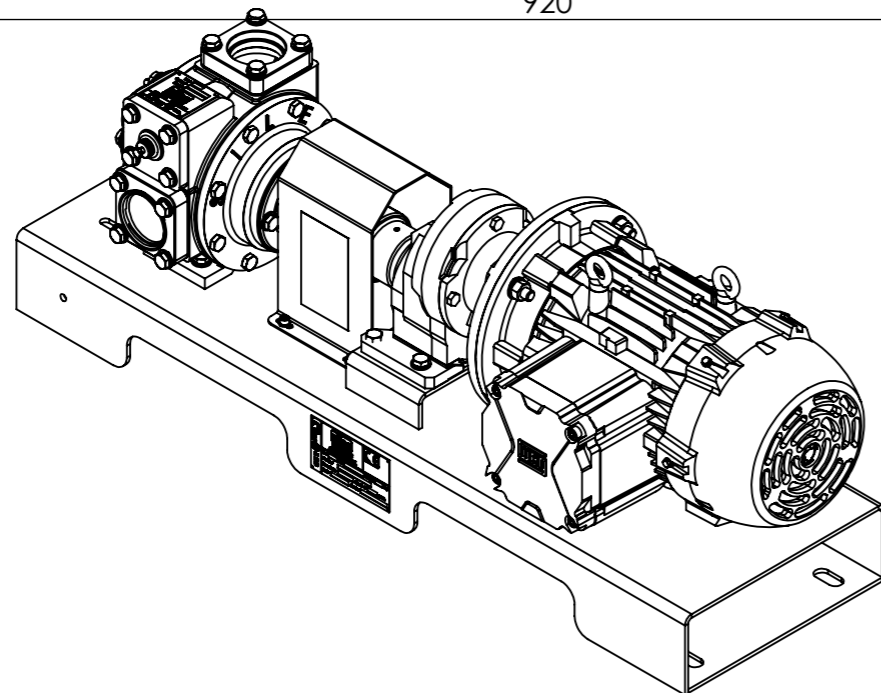

www.silea.it		Description	
<b>silea</b> 50 YEARS SINCE 1968		<b>PUMPING UNIT 2" - 3 HP</b>	
Liquid Transfer S.r.l.		<b>150 lt/min - 35 mt prevalance - 350 rpm</b>	
Material C.I.+C.S.		Treat.Term. o Treat.Superf.	
Rev. 0	Weight kg 91	Drawn by DC	Scale 1:6
Date 25/03/2020	Code 10561320-902	Format A3	