

AIR OPERATED DOUBLE DIAPHRAGM PUMPS



TECHNOLOGY EXCELLENCE

ENVIRONMENT Concerned

Metal die-casting and thermoplastic materials moulding are optimally industrialized and produced using energy efficient and reliable resources.



STATE-OF-THE-ART Machinery

We produce all components in-house, using the most advanced equipment.



QUALITY First

Automated measuring of parts for consistent quality assurance.

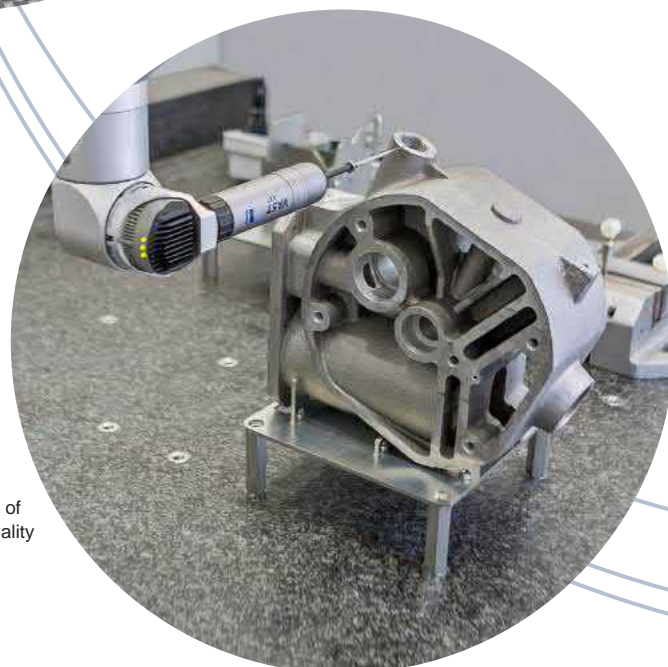



SAMOA Headquarters and
Technical Centre in Gijón (Spain)

SAMOA: LEADING THROUGH INNOVATION

SAMOA, a privately owned company, is a **leading European manufacturer of Lubrication and Fluid Handling Equipment**. SAMOA products are used for transferring, dispensing, dosing, and recovering different types of fluids in multiple industries and applications. SAMOA designs and manufactures **a wide program that includes air operated piston and double diaphragm pumps**, volume flow meters, delivery guns, electronic components for inventory control systems, hose reels, hand pumps and accessories for these products.

Product research and development is a fundamental part of SAMOA's philosophy. We are in permanent contact with the market to identify new customer needs, that we satisfy with existing product improvement and new product development.

SAMOA's headquarters have been in Gijón, on the Spanish North Coast, for over 60 years. SAMOA's manufacturing facilities are modern and equipped with the latest state-of-the-art production equipment and technology. We are **committed to design and manufacturing excellence, environmental sustainability and a healthy and safe workplace**; our work processes and facilities are consequently ISO 9001, ISO 14001 and ISO 45001 certified.

Our products are available through a network of **fully owned subsidiaries and knowledgeable** distributors. This global network provides a sales and consulting service, to identify the products that best meet each customer's needs, and when required offers after sales service to ensure the long and satisfactory use of our equipment.

Our continuous product improvement process ensures that **our products meet customer requirements worldwide**, including in even the most demanding applications and environments. As a result, we are proud to say that SAMOA products are reliably working away, night and day, in more than 100 countries.



**INDIVIDUALLY
Tested**

All pumps are dry, wet, vacuum,
and dead-head verified.

**INTERCHANGEABLE
Parts**

Consistent assembly.

AIR OPERATED DOUBLE DIA

WORKING PRINCIPLE OF AN AODD PUMP

SAMOA Pivot Universal Pumps (UP) are air operated double diaphragm pumps with a reciprocating motion. They have two opposite pump volumes and a diaphragm divides each volume into an air and a liquid chamber. The diaphragms are connected with a shaft. During one pumping stroke, the fluid (blue), is suctioned into one liquid chamber, while simultaneously other fluid (red) volume is discharged from the opposite liquid chamber.

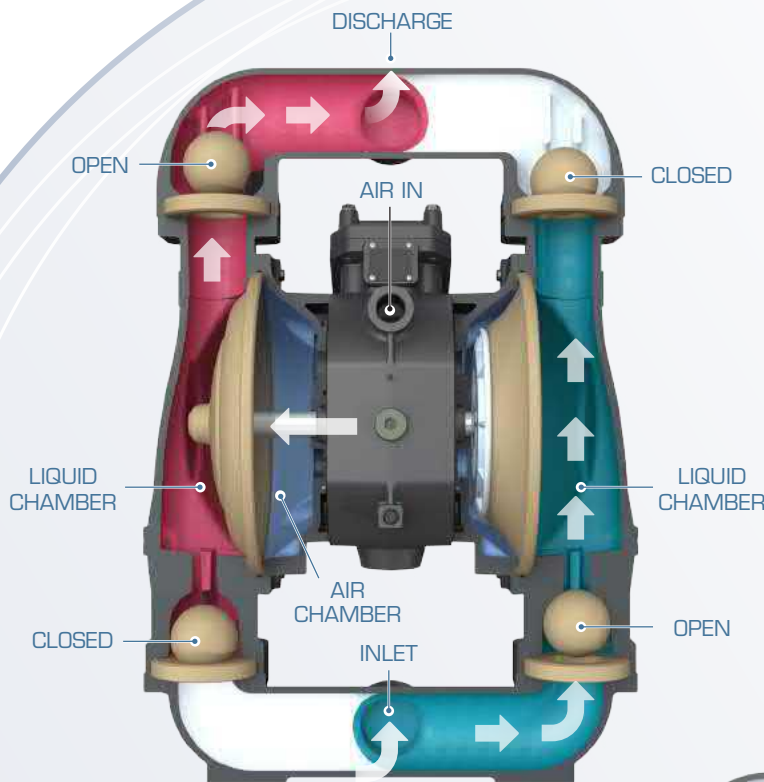

SUCTION STROKE (BLUE)

The air valve in the center of the pump fills the left inner chamber with compressed air, causing the right diaphragm to create a suction, lifting the lower check valve and pulling fluid in at inlet. Simultaneously, the left chamber is in Discharge Stroke (red).

DISCHARGE STROKE (RED)

The air valve alternates the air flow, which now fills the right air chamber, causing the upper check valve to open and discharge fluid. Simultaneously, the left chamber is working in Suction Stroke (blue).

A suction stroke and a discharge stroke constitute a complete pump cycle. The pump may take several cycles to complete prime depending on the application conditions.

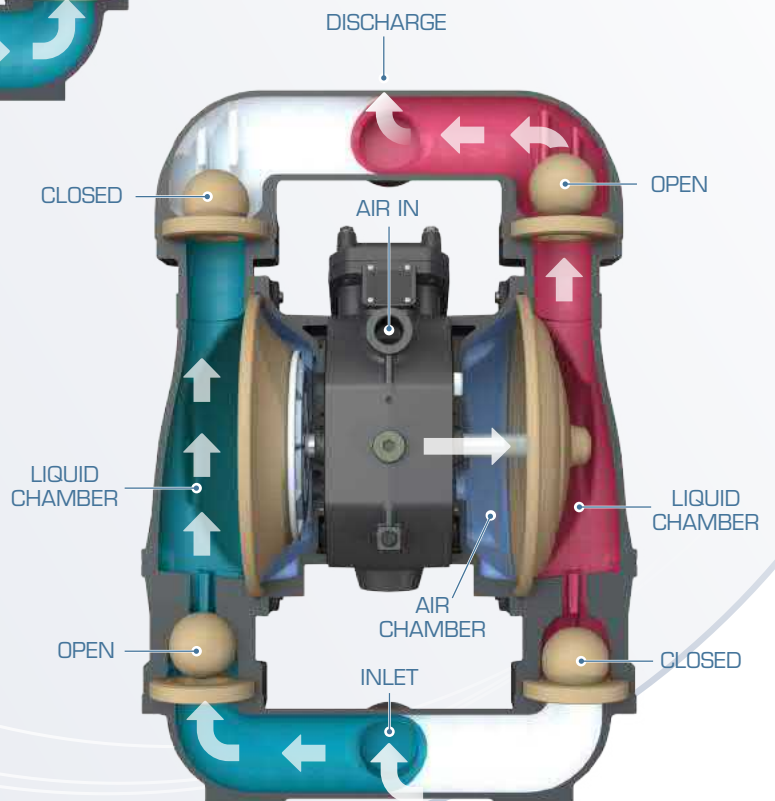

DIAPHRAGM (AODD) PUMPS

INSTALLATION OF AODD PUMPS

AODD pumps are suitable for a wide variety of applications: as fixed installations in process applications or as portable or mobile units, for easy transport to different places of use. All AODD are able to run dry.

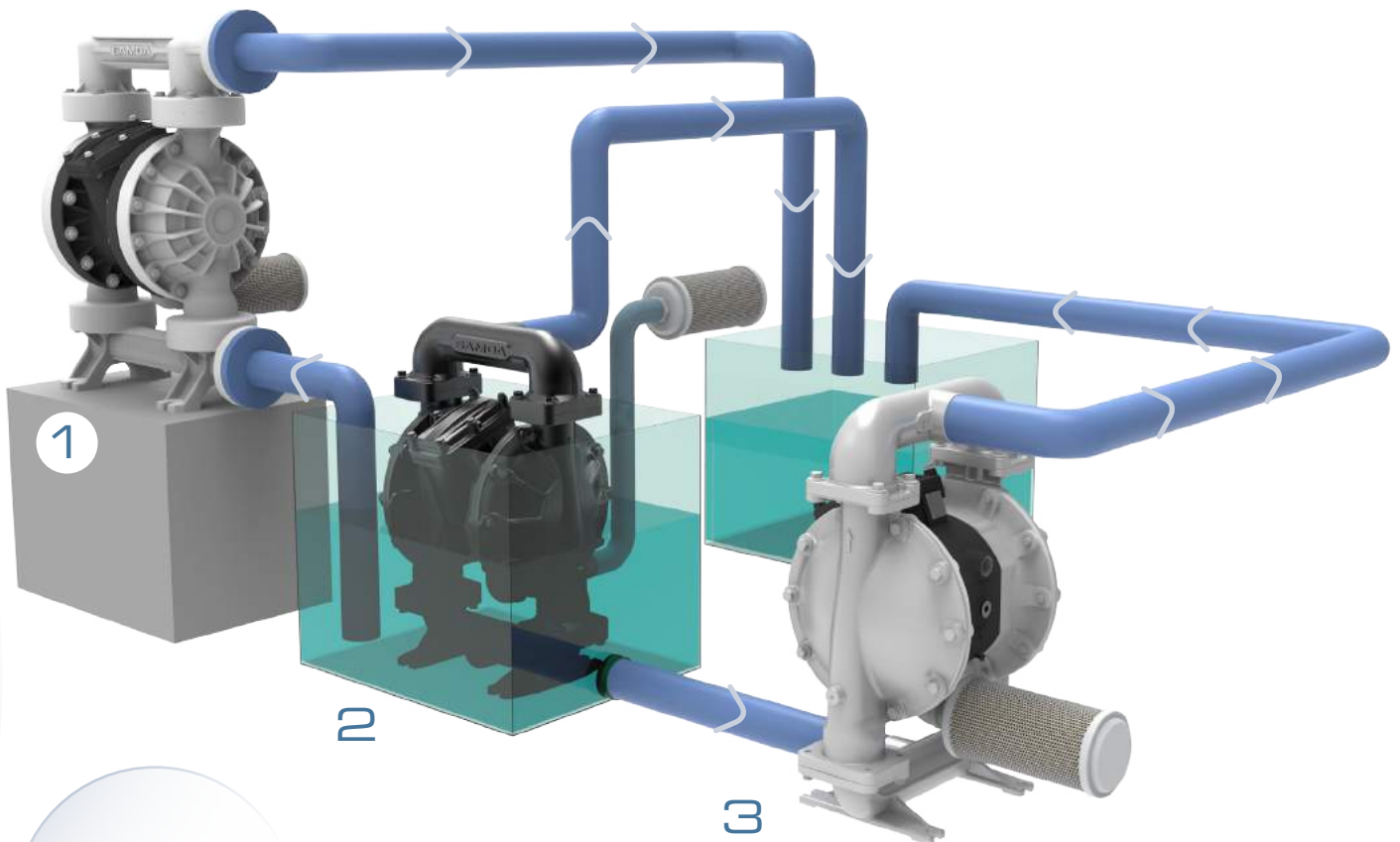

1. SUCTION LIFT

- Dry self-priming.
- Max lift up to 8,3 m (28') (water) with an adequate filler suction pipe.

2. SUBMERGED

- Pump can be totally submerged in the pumped liquid.
- Air exhaust outlet must be above the fluid level.
- Pump central body materials must be compatible with the pumped liquid.

3. FLOODED SUCTION

- Most common installation.
- Adequate for viscous fluids.
- Suction side inlet pressure should not exceed max. 0,7 bar / 10 psi and 7 m - 21' water column .

UP: PIVOT UNIVERSAL PUMP

The new SAMOA Pivot Universal Pump (UP) combines a Universal design with a unique frictionless Pivot Air Valve to provide maximum performance and energy efficiency, exceeding market expectations.

ADVANTAGES OF AODD PUMPS

Dry-running capability.

Dry self-priming.

Can pump clean fluids or fluids with suspended solids.

Best pump for abrasive, corrosive and shear sensitive fluids.

Air driven pump, no electricity required, no electrical hazard.

Can be submerged completely with no performance or safety issues.

On-demand operation. Pump stops when fluid outlet closes and automatically starts when the fluid outlet opens.

Adjustable flow and discharge pressure with only an air pressure regulator.

No dynamic mechanical seals or packings.



ADDITIONALLY, UP SERIES PUMPS OFFER:

HIGHER EFFICIENCY: Maximum fluid flow with reduced air consumption, versus competitive pumps.

INCREASED RELIABILITY: No stall, no icing, and reliable start-up even with the lowest air pressure.

MINIMAL VIBRATION AND PULSATION: Thanks to the fast action Frictionless Pivot air valve.

BOLTED CONSTRUCTION: Provides better seal and eliminates pump leaks. Same size bolts in covers and manifolds for easier maintenance.

EASIER SERVICING: Components designed for a simpler and easier maintenance, with reduced number of parts.

UNIVERSAL PUMP: Matches relative dimension of main competitive brands. Direct replacement for existing installed pumps.

SUPERB ABRASION RESISTANCE: Optimized design manifolds and fluid paths reduce fluid speed and minimize wear caused by abrasion.

ADVANTAGES

AODD PUMPS VS. OTHER PUMP TECHNOLOGIES



PUMP TYPES

AODD Diaphragm

Piston / Plunger

Peristaltic Hose

Lobe

Vane

Gear

Centrifugal

Pump Classification PD = Positive Displacement Pump	PD Reciprocating	PD Reciprocating	PD Rotary	PD Rotary	PD Rotary	PD Rotary	Kinetic

PUMPED FLUID CHARACTERISTICS

SUSPENDED SOLIDS No pump or product damage	▲	▼	▬	▼	▲	▬	▬
ABRASIVE SLUDGE & SLURRIES Low internal velocities-No damage	▲	▼	▲	▼	▼	▼	▲
CORROSIVE FLUIDS Compatible pump materials	▲	▼	▲	▬	▼	▼	▼
SHEAR SENSITIVITY Low shear and product separation	▲	▼	▼	▲	▼	▼	▼

PUMP OPERATION

DRY-RUNNING CAPABILITY No pump or system damage	▲	▲	▲	▼	▬	▼	▼
DRY SELF-PRIMING High suction-lift	▲	▬	▼	▼	▼	▼	▼
PORTABLE & SUBMERSIBLE Integral pump with air motor	▲	▼	▼	▼	▼	▼	▬
COOL OPERATION No heat build-up during transfer	▲	▬	▬	▬	▬	▬	▬
SAFETY (ATEX models) Air Driven. No electrical hazard	▲	▬	▬	▬	▬	▬	▬

PUMP COST ADVANTAGES

ON-DEMAND OPERATION Bypass and relief valves cost savings	▲	▲	▬	▬	▬	▬	▬
ADJUSTABLE FLOW & PRESSURE Additional regulation costs savings	▲	▬	▬	▬	▬	▬	▬
DYNAMIC & MECHANICAL SEALS Replacement and maintenance cost savings	▲	▼	▼	▼	▼	▼	▼
NO ELECTRICAL INSTALLATION Intrinsically safe, cost savings	▲	▼	▼	▼	▼	▼	▼
INITIAL PURCHASE PRICE Compared to other pump types	▲	▼	▼	▼	▼	▼	▼

▲ = Excellent

▬ = With limitations

▼ = Not recommended

APPLICATIONS AND INDUSTRIES

PROCESS INDUSTRY



MINING



WATER/WASTE WATER



ENERGY INDUSTRY



UP PUMPS CODING SYSTEM



Example: UP20A-BAC-HHC

CENTRAL BODY SPECIFICATIONS

1 PUMP TYPE

UP = Universal Pump (Bolted type)
UE = Pump with electronic interface

2 PUMP SIZE – Connection Ports (Ø)

20 - 2" (51 mm)
30 - 3" (76 mm)

3 AIR MOTOR & AIR CHAMBERS

A = Aluminium
B = Conductive Polypropylene-ATEX
L = Conductive Polypropylene-ATEX
with air chambers in AISI 316
Stainless Steel
S = Aluminium with air chambers in
AISI 316 Stainless Steel

HOUSINGS SPECIFICATIONS

4 FLUID CONNECTION PORTS

B = BSP (Threaded - Central Location)
N = NPT (Threaded - Central Location)
C = ANSI/DIN (Flanged-Central Location)
F = ANSI/DIN (Flanged-Side Location)

5 FLUID CHAMBERS/MANIFOLDS

A = Aluminium
F = Ductile Iron
P = Polypropylene / 1 Port
B = Conductive Polypropylene-ATEX / 1 Port
S = AISI 316 Stainless Steel
W = PVDF / 1 Port

6 HARDWARE (Bolts)

C = Carbon Steel
S = Stainless Steel

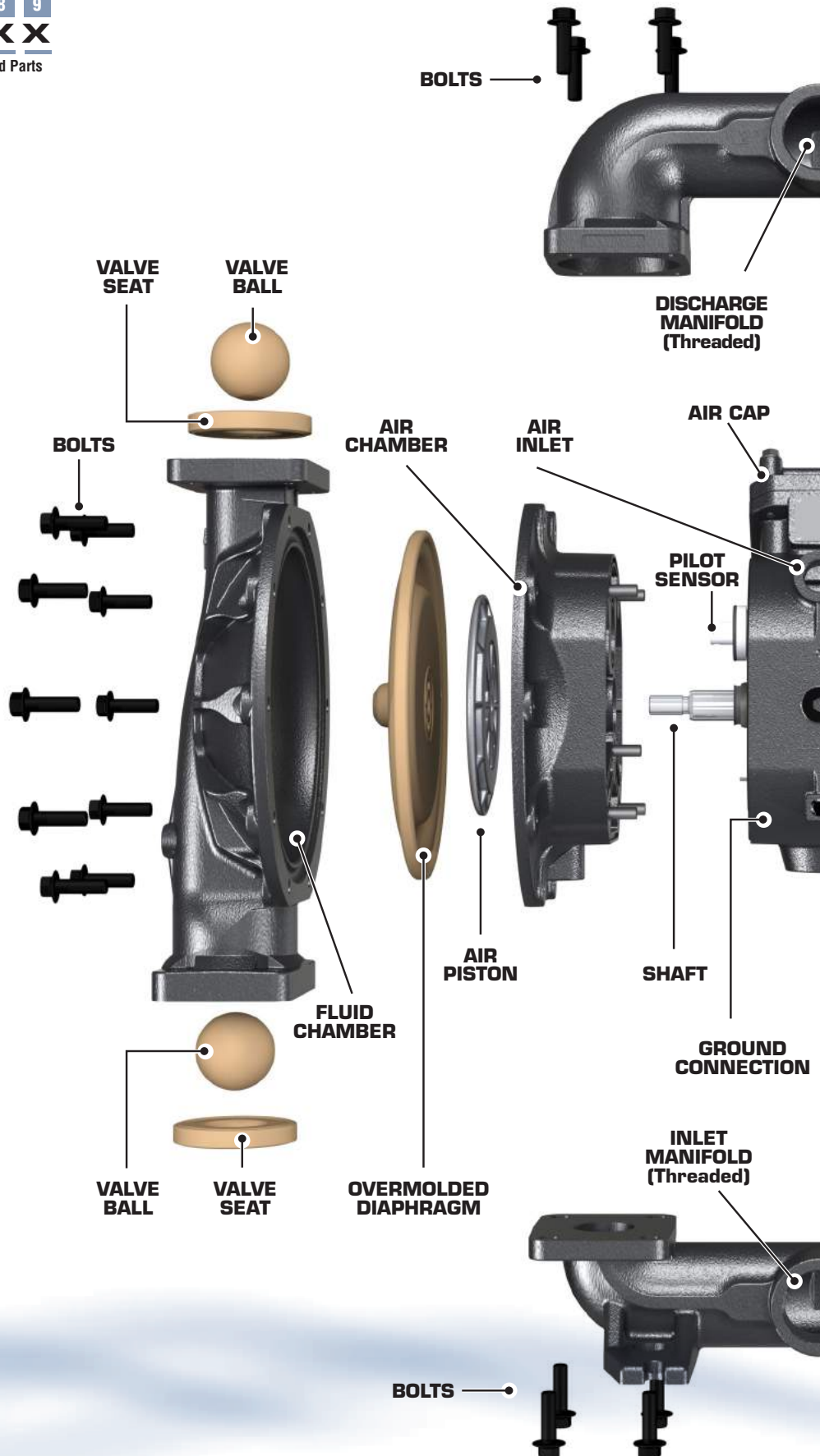

FLEXIBLE, MODULAR DESIGN

Flexible and modular design pumps concept for the widest product range and for all pump sizes.

Quick change of wetted parts (diaphragms, seats and balls) makes any pump suitable for use with other fluids.

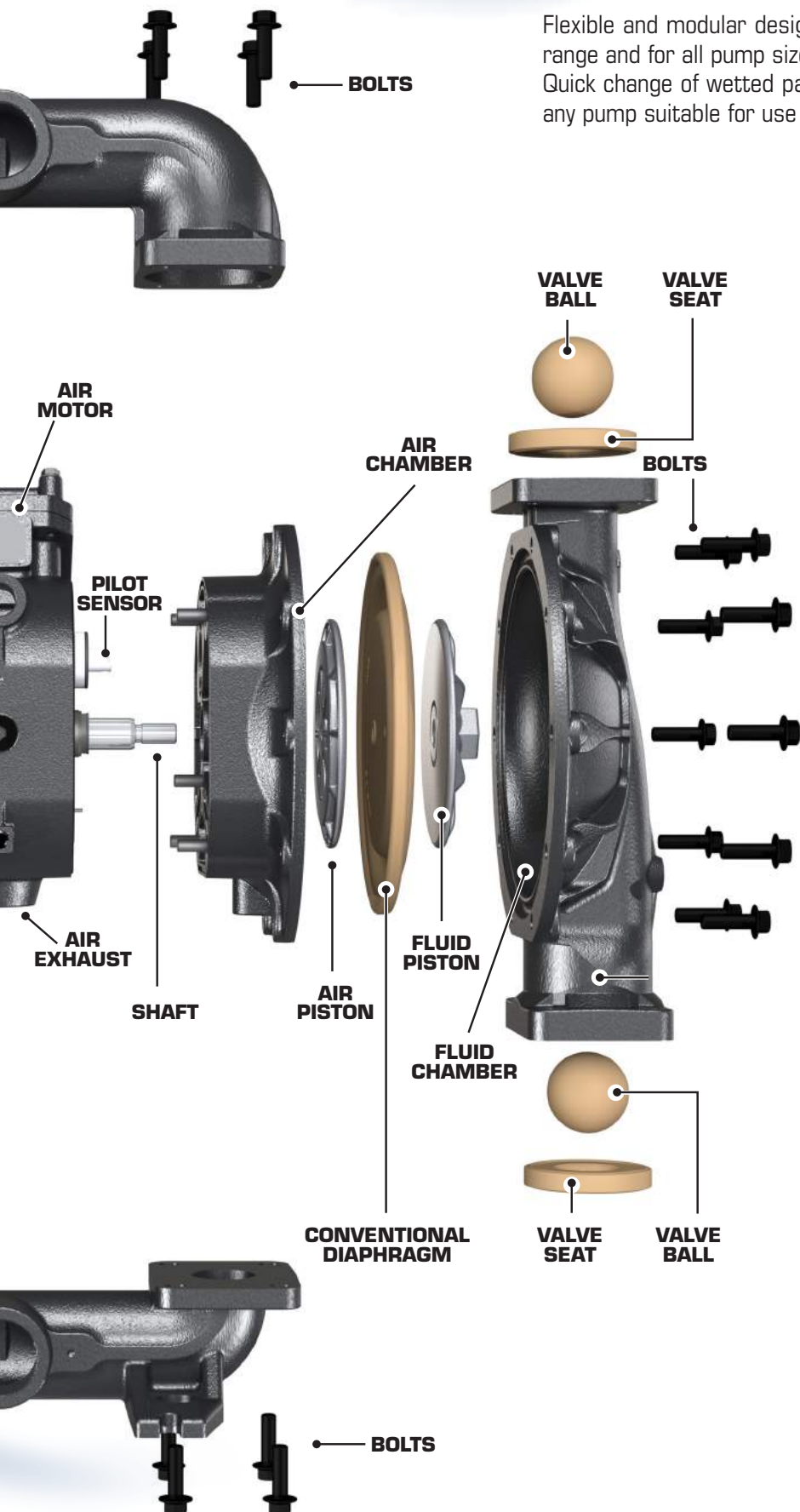

WETTED PARTS SPECIFICATIONS

7 VALVE SEATS MATERIAL OPTIONS

A = Aluminium
 D = AISI 440 Hardened Stainless Steel
 H = Hytrel®
 M = Santoprene®
 N = NBR (Buna-N)
 P = Polypropylene
 S = AISI 316 Stainless Steel
 T = PTFE (Teflon®)

8 VALVE BALLS MATERIAL OPTIONS

H = Hytrel®
 M = Santoprene®
 N = NBR (Buna-N)
 S = AISI 316 Stainless Steel
 T = PTFE (Teflon®)
 V = FKM (Viton®)

9 DIAPHRAGM MATERIAL OPTIONS

Conventional Diaphragm (with exposed fluid piston)

A = Santoprene®
 C = Hytrel®
 G = NBR (Buna-N)
 V = FKM (Viton®)
 Z = PTFE with Santoprene® backer

Overmolded one piece Diaphragm (inserted fluid piston)

M = Santoprene®
 H = Hytrel®
 T = PTFE/EPDM-Bonded
 N = NBR (Buna-N)

Not all material options are available to all pump sizes.

UP PUMP SIZE SELECTION &

PUMP SIZE - PERFORMANCE CHARTS

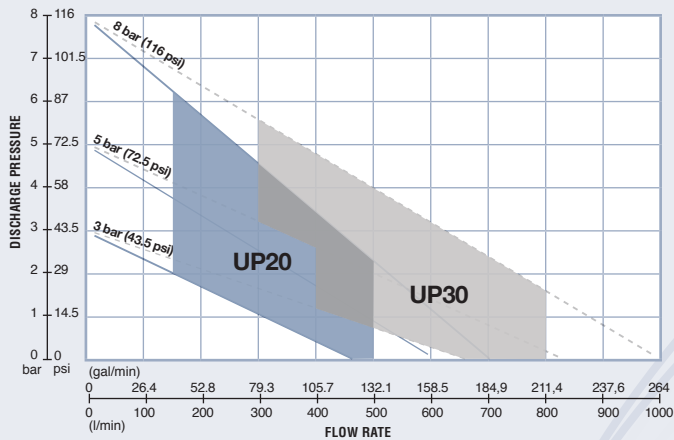

The desired flow rate and discharge pressure required can be met, for most applications, by multiple pump sizes. The optimal size is achieved when the expected pump working conditions are in the middle part of its Performance Chart. Selecting the larger size pump will result in less repair downtimes and parts, labor and energy cost reductions, thus bringing down the apparent initial investment.



HOW TO READ A PUMP PERFORMANCE CHART

Pump performance chart provides data how a particular pump performs at certain conditions. The left scale of the chart shows discharge outlet pressure and the bottom scale on the chart shows the flow rate. Performance chart can also show the pump air consumption (dotted line on the chart).

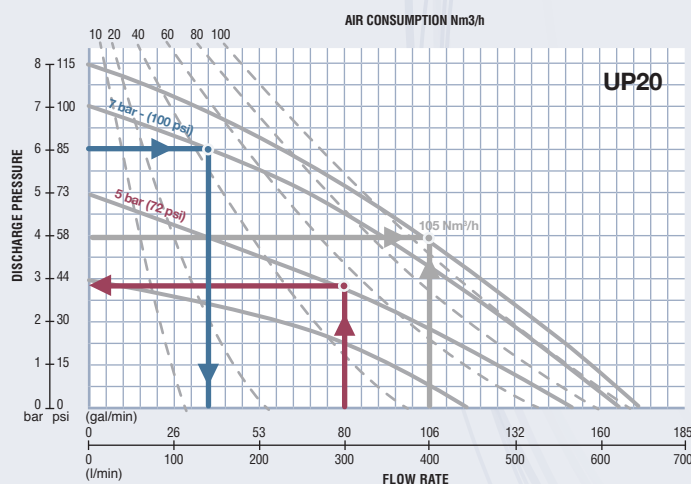

Chart obtained with water at room temperature (20 °C - 70 °F).

--- AIR CONSUMPTION
— PUMP FLOW



TO FIND THE PUMP DISCHARGE PRESSURE

1. Locate the desired flow rate along the bottom of the chart (300 l/min).
2. Follow the vertical line up to the intersection with the pump capacity curve at the fixed air inlet pressure (5 bar).
3. Follow this point left and read the pump discharge pressure (Close to 3 bar).



TO FIND THE PUMP FLOW RATE

1. Locate the known discharge pressure drop on the left of the chart (6 bar).
2. Follow a horizontal line to the intersection with the pump capacity curve at the fixed air inlet pressure (7 bar) feeding the pump.
3. Follow this point down and read the pump flow rate (140 l/min).
4. Air consumption in this case is 45 Nm³/h.



TO FIND THE AIR INLET PRESSURE AND AIR CONSUMPTION

1. Locate the desired flow rate along the bottom of the chart (400 l/min) and follow a vertical line.
2. Locate the known discharge pressure on the left of the chart (4 bar) and follow a horizontal line.
3. The intersection of these two lines determine the pump operating point. Air inlet pressure should be set at 8 bar and the air consumption would be 105 Nm³/h.

PERFORMANCE CHARTS

PUMP CAPACITY, SUCTION LIFT AND FLUID VISCOSITY.

SUCTION LIFT

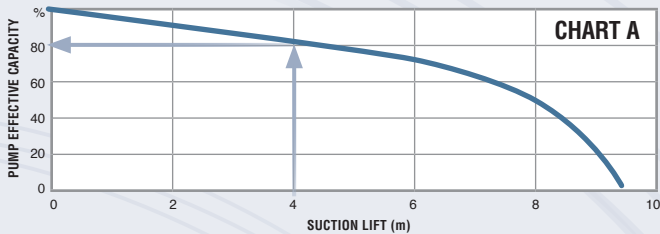

Pump capacity decreases when the suction lift increases. To find out how much the pump capacity can be reduced, use chart A.

Example:

300 l/min theoretic delievery (water) and 4 m suction lift

1. Locate the suction lift in meters along the bottom of chart A (4 m).
2. Follow a vertical line up to the intersection with the curve on the chart.
3. Follow this point to the left and read the pump effective capacity (80%).

FLOW RATE = THEORETIC FLOW RATE X EFFECTIVE CAPACITY/100

Flow rate = 300 l/min x 0,8 = 240 l/min

FLUID VISCOSITY

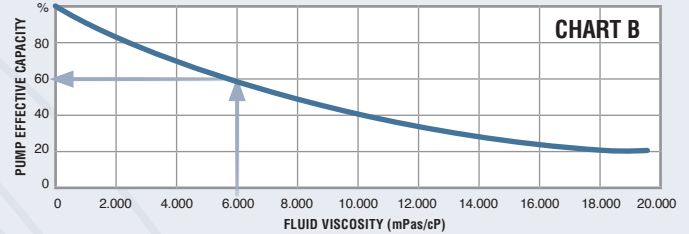

Pump capacity decreases when the fluid viscosity increases. To find out how much the pump capacity can be reduced, use chart B.

Example:

300 l/min theoretic delievery (water) and 6.000 mPas / cPs fluid viscosity

1. Locate the fluid viscosity in mPas / cPs along the bottom of chart B (6.000 mPas) .
2. Follow a vertical line up to the intersection with the curve on the chart.
3. Follow this point to the left and read the effective pumps capacity (60%).

FLOW RATE = THEORETIC FLOW RATE X EFFECTIVE CAPACITY/100

Flow rate = 300 l/min x 0,6 = 180 l/min

The suction lift flow reduction and the viscosity flow reduction accumulate. If you are pumping a fluid with 6000 mPas viscosity, the installation has 4 m suction lift and if the theoretic delivery (water) is 300 l/min, the real delivery would be:

FLOW RATE = THEORETIC FLOW RATE X EFFEKTIVE CAPACITY DUE TO SUCTION LIFT/100 x EFFECTIVE CAPACITY DUE TO FLUID VISCOSITY/100

Flow rate = 300 l/min x 0,8 x 0,6 = 144 l/min



High suction lift reduces pump delivery.



High fluid viscosity reduces pump delivery.

AIR DISTRIBUTION SYSTEM

SAMOA Pivot Universal Pump (UP) combines the innovative concept of their Air Distribution System (Central Body, Air Covers, Air Valve and Pilot Sensors) with an enhanced Universal Air Operated Double Diaphragm Pump design.

The exclusive Air Distribution System (ADS) incorporates an innovative Pivot-Valve together with the "Smooth-Start-Shifter" (3S) actuator (patented). It provides a reliable operation with very low air pressure and / or low air flow.

Additionally ADS design also prevents freezing and delivers higher and smoother flow with reduced air consumption when compared to other competitive AODD Pumps. Thanks to its modular concept, Samoa ADS is very simple to clean and maintain.

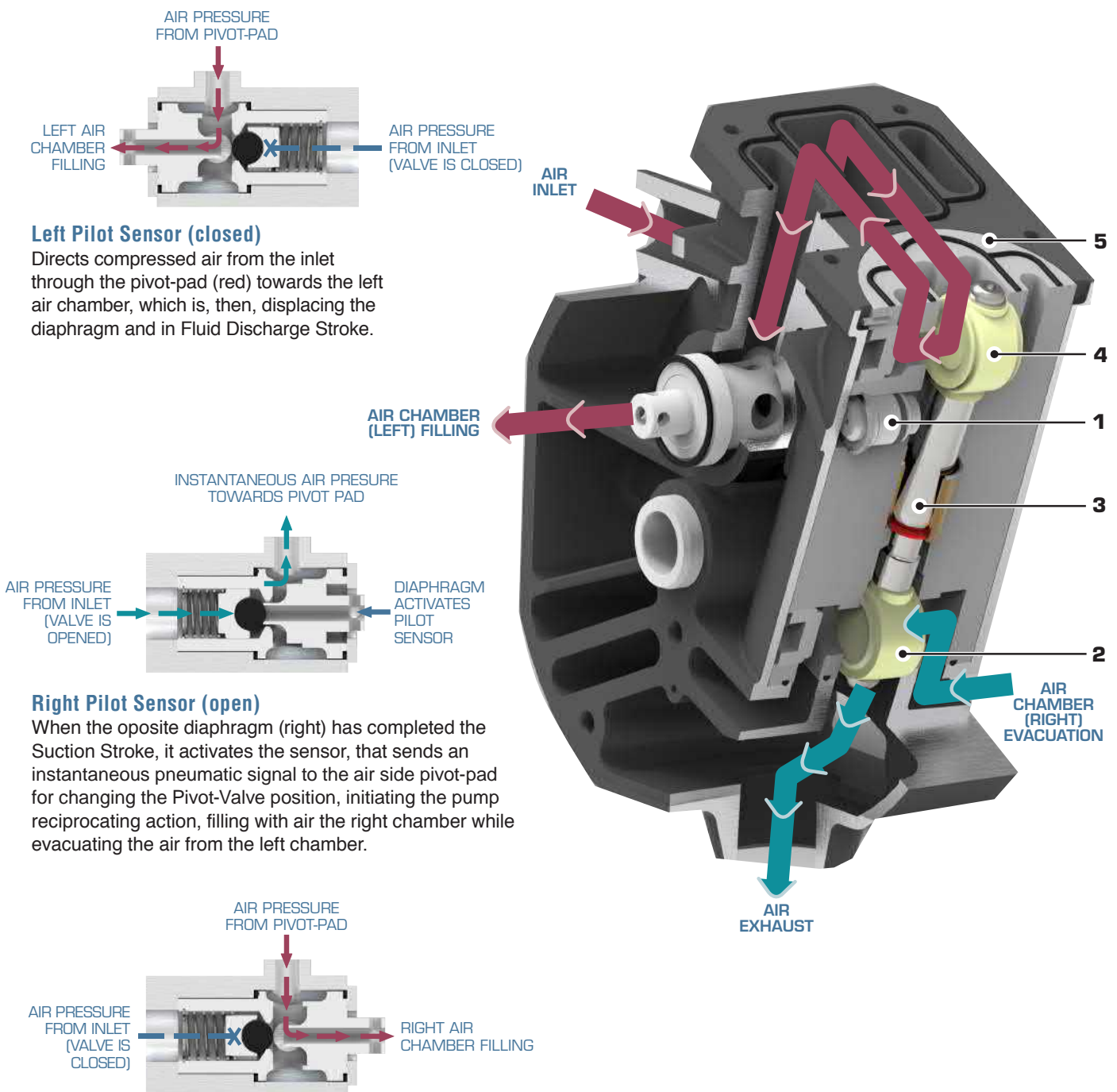

RELIABILITY, EFFICIENCY AND SIMPLICITY



AIR VALVE

- With an innovative cartridge design, the air valve assembly can be easily removed and cleaned or replaced if necessary, reducing pump down time.
- Air valve has the fewest moving parts in the industry: no spools, no o-rings. Unique Frictionless Pivot Valve.
- On-Off-On maximum reliability. Patented Smooth Start Shifter (3S) actuator activates the pivot-valve for reliable start on-demand systems, even with reduced air pressure.
- **Air valve cartridge manufactured in aluminium for metal pumps and in conductive polypropylene for non-metal pumps.**

RUNS WITH DRY, DIRTY OR DAMP AIR.

LUBE-FREE OPERATION.

LONG LIFE PIVOT-PADS.

1. NO PUMP STALLING

SAMOA UP Series pumps do not stall even with low air pressure, as it can happen with other pumps. The patented "Smooth Start Shifter" (3S) actuator activates the pivot-shaft of the frictionless pivot-valve just when needed and thus prevents stalling.

2. NO PUMP FREEZING

The pivot-shaft action exhausts one air chamber to the atmosphere, for fast air evacuation, while compressed air simultaneously fills the opposite air chamber. The two large sides of the exhaust pivot-pad act as fast dump valves to exhaust the used air from each chamber directly through the exhaust port and muffler. This prevents freezing and pump slowdown.

3. SMOOTH FLOW

The unique ADS, which combines two end of stroke sensors that send an instantaneous pneumatic signal with the frictionless pivot-valve, provides the fastest reciprocating action in the industry against conventional spool or sliding block valves. This contributes to provide a smoother flow and reduced vibration when compared to many competitor AODD pumps.

4. EFFICIENT PUMP

The close tolerances at the ADS air inlet pivot-pad check-valves and the optimized pilot-sensors, avoid internal air leaks, reduce air consumption and optimize the flow delivery versus most of competitors' AODD Pumps.

5. SIMPLE MAINTENANCE

The ADS used in the Pivot Universal Pumps has the fewest number of moving parts in the Industry. Its modular and easy to replace design contributes to reduce downtime and simplifies maintenance. The air valve module is fully accessible and can be replaced in minutes, while the pump is installed in line.

CENTRAL BODY SPECIFICATIONS

The pump central body, air covers, air cap and the air valve together with the Pilot Sensors, the diaphragms connecting shaft and the air pistons form the pump air motor.

- All bolted construction: Safe-reliable-strong. Easy maintenance.
- Robust central body and air cap protect air valve by acting as a shield against accidental impact damage.
- Fully groundable for ATEX versions.
- Well dimensioned air inlet, air ducts, and pilot sensor valves eliminate pump problems caused by obstruction due to poor air quality.
- Large exhaust port and high-performance muffler for no ice formation and low noise level.
- Diaphragms connecting shaft, durable and highly resistant to corrosion. Male threaded ends.

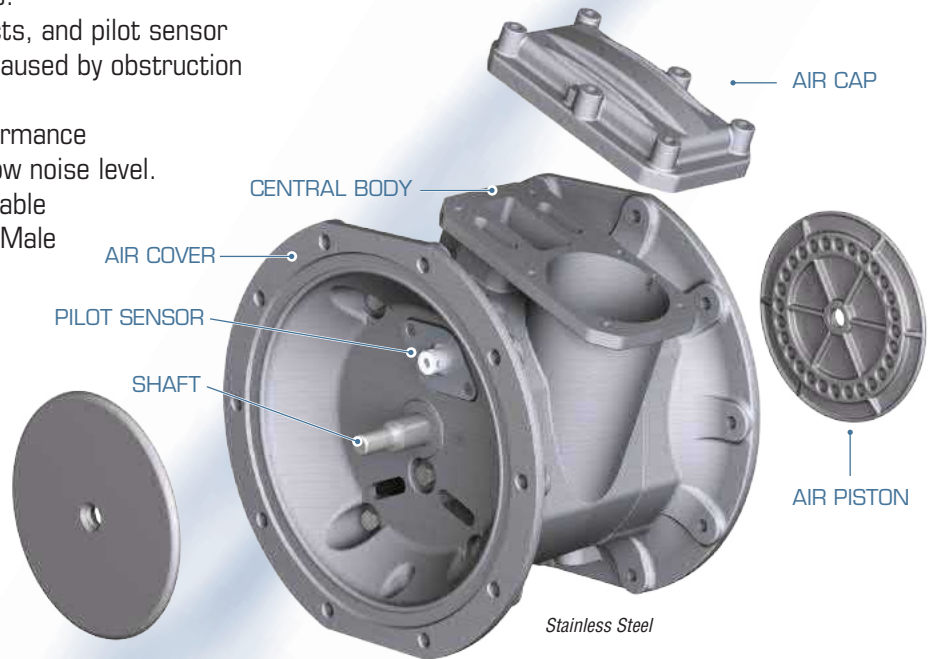

CENTRAL BODY, AIR COVERS, AIR CAP AND AIR PISTONS MATERIALS

ALUMINIUM

- Versatile material with good overall properties. For general purpose applications.
- Enhanced corrosion resistance by application of a Urethane Epoxy, UE-coat, for internal and external protection, once parts have been machined.
- Used in central body, air covers, air cap and and air pistons.
- Used in metallic pumps with aluminium, stainless steel and ductile iron fluid chamber covers and manifolds.

STAINLESS STEEL

- High level of corrosion resistance, mostly used in the chemical industry.
- AISI 316 Stainless steel.
- Used in air covers and air pistons combined with either aluminium or conductive polypropylene central body.
- Used with pumps with stainless steel fluid chamber covers and manifolds.

CONDUCTIVE POLYPROPYLENE

- General purpose thermoplastic material.
- Presents wide chemical compatibility.
- Conductive polypropylene can be grounded and complies with ATEX certification requirements.
- Used in central body, air covers and air cap.
- Used with pumps in polypropylene, conductive polypropylene and PVDF.
- Conductive polypropylene central body, combined with stainless steel air chambers and air pistons, may be used in pumps with stainless steel fluid chamber covers and manifolds.



Aluminium



Conductive polypropylene

FLUID CHAMBERS & MANIFOLDS SPECIFICATIONS

QUICK SELECTION GUIDE

Selecting the right pump materials for your application will ensure economic operation and longer service intervals caused by failures, repairs, maintenance and pump changes.

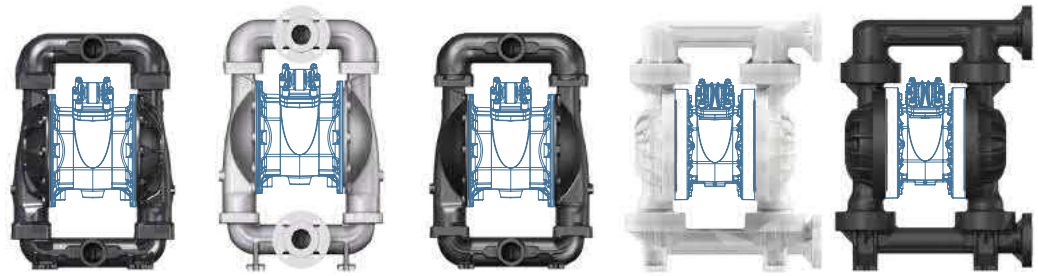

	METALLIC			NON METALLIC		
	ALUMINIUM	STAINLESS STEEL 316	DUCTILE IRON	POLYPROPYLENE NATURAL	POLYPROPYLENE CONDUCTIVE	PVDF

PUMP COST PRICE	\$	\$\$\$\$	\$\$	\$\$\$	\$\$\$\$	\$\$\$\$\$\$
-----------------	----	----------	------	--------	----------	--------------

HOUSINGS & FLUID CHARACTERISTICS

Solids in suspension	A	A	A	B	B	B
Large size solids non-suspended	C	C	C	D	D	D
Sludge/Slurry	B	B	B	C	C	C
Abrasive fluids. High	B	B	A	D	D	D
Abrasive fluids. Medium	A	B	A	C	C	C
Abrasive fluids. Low	A	A	A	B	B	B
Corrosive fluids (Chemicals)	D	B	C	A	A	A

HOUSINGS & INSTALLATION TYPE

Flooded Suction installation	A	A	A	B	B	B
Suction lift installation	A	A	A	C	C	C
Submerged installation	B	C	A	C	C	C
High pressure-drop in the line	A	A	A	B	B	B
Fluid Containment (Bolted pump) (Oil & Gas, Paints, Inks, Acids appl.)	A	A	A	A	A	A

HOUSINGS & DUTY CYCLE (COMPARED TO OTHER PUMP TECHNOLOGIES)

Intermittent/On-Demand	A	A	A	A	A	A
Continuous operation every day	B	B	B	B	B	B

A = Excellent – B= Good – C= With limitations – D= Not recommended

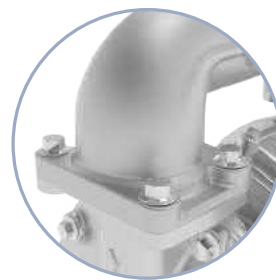
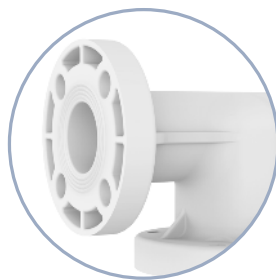
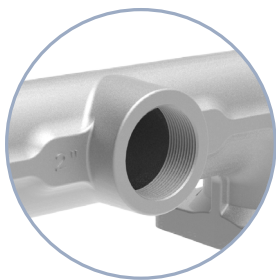

FLUID CONNECTION PORTS

- Threaded connections (female threads) for Metallic Pumps: BSP (parallel) and NPT (Tapered) threads available.
- ANSI / DIN Flange connections for Non-Metallic and Metallic Pumps. Manifold flange is off-set to avoid potential leaks dropping on pump footprint.

HARDWARE-BOLTS

- All bolted construction for Safety, Reliability and easy Maintenance.
- Maximum process fluid containment. Uniform torque around the seal or the diaphragm.
- Withstands four times the pressure versus clamped pumps, preventing leakage under high pressure and dead-head conditions.
- No need to change seal after repeated maintenance services. Lower repair cost for elastomer valve seats.
- One size bolt used to fit all pump housing parts.
- Bolts available in Carbon Steel (black passivated) or Stainless Steel.

FLUID CHAMBERS SPECIFICATIONS



AISI 316 Stainless Steel

METALLIC PUMPS

ALUMINIUM

- Versatile material with good overall properties. For general purpose applications.
- Enhanced corrosion resistance by application of a Urethane Epoxy "UE-Coat" for internal and external protection once part has been machined.
- Carbon steel (black) hardware bolts as a standard and stainless steel on demand for aggressive locations.
- Temperature range: -10 °C to +130 °C (+14 °F to +266 °F).
- Not for use with halogenated hydrocarbons.

AISI 316 STAINLESS STEEL

- High corrosion resistance, mostly used in the chemical industry. Standard die-cast surface roughness.
- High tensile resistance.
- Can be used with a wide range of chemical products.
- Temperature range: -25 °C to 130 °C (-13 °F to 266 °F).

DUCTILE IRON

- High abrasion resistance, mostly used in mining, pulp and paper industry and with abrasive materials.
- High tensile resistance.
- Temperature range: -10 °C to 130 °C (+14 °F to 266 °F).



Aluminium



Ductile Iron



Polypropylene (Natural)



PVDF (Polyvinylidene Fluoride) Kynar®

NON-METALLIC PUMPS

POLYPROPYLENE (NATURAL OR CONDUCTIVE)

- A thermoplastic polymer. General purpose, low cost material.
- Moderate tensile resistance and flex strength.
- Commonly used in chemical, paint, galvanic & coating, oil & gas industries, power stations and certain mine dewatering applications.
- Good with water soluble acids and caustics.
- White colour.
- Also available as electricity conductive Polypropylene (black colour) for groundable pump version (ATEX).
- Temperature range: 0 °C to 65 °C (+32 °F to 150 °F).

PVDF (Polyvinylidene Fluoride) Kynar®

- A fluoroplastic, durable and with excellent chemical resistance.
- Dark gray colour.
- High tensile strength and impact resistance.
- Excellent temperature resistance.
- Temperature range: -40 °C to 121 °C (-40 °F to 250 °F).

Always check chemical compatibility of the selected materials.

FLUID MANIFOLDS SPECIFICATIONS

- Optimised fluid path and cross section for minimum internal friction.
- Bolted for enhanced safety, sealing capacity, reliability and easy assembly and disassembly. Four bolts pattern per union.
- The discharge and inlet manifolds can be rotated 180° for accommodating their connection to inlet/discharge fluid lines.
- Designed to drop-in as a pump fit-replacement for existing systems which incorporate competitor's pumps.
- Available with either BSP or NPT female threads or DIN / ANSI flange coupling in Metallic pumps and DIN/ANSI flange coupling in Non-Metallic pumps.



Aluminium

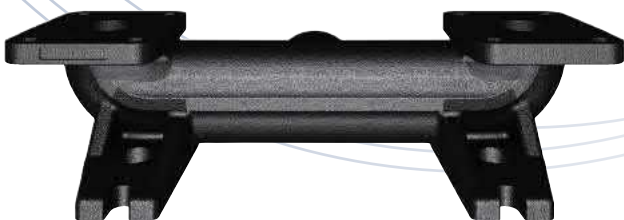

AISI 316 Stainless Steel



Ductile Iron



Polypropylene (Natural)



PVDF (Polyvinylidene Fluoride) Kynar®



METALLIC MANIFOLDS

ALUMINIUM

- Versatile material with good overall properties. For general purpose applications.
- Thick wall construction in Casted Aluminium.
- Especially suitable for abrasive slurries, high capacity for solids handling. Adequate for use in the ceramic industry.
- Enhanced corrosion resistance by application of a Urethane Epoxy "UE-Coat" for internal and external protection once parts have been machined.
- Carbon steel (black) hardware bolts as a standard. Stainless steel bolts on demand for aggressive locations.

AISI 316 STAINLESS STEEL

- High corrosion resistance level, mostly used in the chemical industry. Standard die-cast surface roughness.
- High tensile resistance.
- Stainless steel hardware bolts.

DUCTILE IRON

- High abrasive resistance degree, recommended use in mining dewatering, pulp and paper industries and with abrasive materials.
- High Tensile resistance.
- Stainless Steel hardware bolts as standard.

NON-METALLIC MANIFOLDS

- Thick wall construction.
- Off-set manifold ports connections. Potential leaks would drop outside the pump footprint.
- Stainless Steel bolts as standard.

POLYPROPYLENE (NATURAL OR CONDUCTIVE)

- High corrosion resistance. Commonly used in chemical, paint, galvanic & coating, oil & gas industries, power stations and certain mine dewatering applications.
- White colour.
- Available as Electrically Conductive Polypropylene (black colour) for groundable pump version (ATEX).

PVDF (Polyvinylidene Fluoride) Kynar®

- A Fluoroplastic, durable and with excellent chemical resistance.
- Dark gray colour.
- High tensile strength and impact resistance.
- Excellent temperature resistance.

Always check chemical compatibility of the selected materials.

CHECK-VALVES SPECIFICATIONS

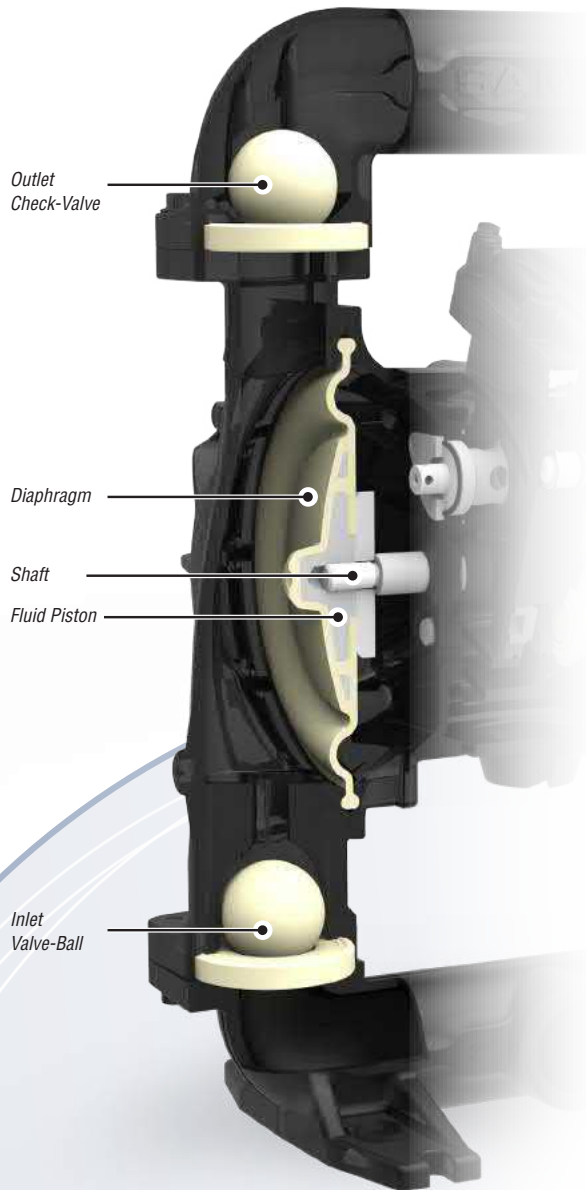

Air Operated Double Diaphragm Pump design is so simple because it only has six dynamic wetted parts: two diaphragms connected by means of a fluid piston with a reciprocating shaft, two inlet check-valves and two outlet check-valves. Diaphragms action forces the valve-balls to open and close on valve-seats thus directing the fluid flow.

Check-valves design facilitates maintenance. Valve-seats and valve-balls can fit, in most cases, all pumps, within the same size, regardless the manifolds and fluid chambers material. Their modular design allows full interchangeability.

Check-valves are formed by the combination of valve-balls, valve-seats and o-rings (required with hard valve-seats). Their materials must be carefully selected to guarantee chemical compatibility with the fluid pumped. This way problems such as swelling, cracking, or sticking do not appear and pump performance is not affected. Abrasive products can wear out the valve-seats increasing their internal diameter and ball-valves can get stuck in them. In this case, balls and seats must be replaced.

Check valve materials combination can respond to one or more of the following criteria:

- Maximum chemical and harsh environment resistance.
- Maximum abrasion resistance.
- Good, general purpose resistance.
- Heavier valve-balls for use with viscous products.
- Resistance to petroleum based products.
- High fluid temperature resistance.

VALVE-BALLS

- The function of the valve-balls is to seal and to un-seal on the valve-seats, thus allowing fluid discharge and suction.
- The valve-balls are generally made from the same elastomeric material as the diaphragm.
- Heavy balls can also be made of Stainless Steel for use with viscous fluids.
- The valve-balls move into formed cages in the fluid chambers and the manifolds. Occasionally, due to abrasion, these cages must be inspected to evaluate excessive wear or damage.
- The balls are spherical, grounded and well balanced to guarantee a good performance and they shall be regularly inspected for nicks, bites, chemical attack or abrasive wear and consequently replaced if necessary.

VALVE-SEATS

- The valve-seat function is to provide the valve-ball with a place to seal.
- They can be made of elastomer and they do not require additional o-rings to seal the fluid at the cage. Elastomer valve-seats are reversible for double life.
- Hard valve-seats require additional o-rings to seal the fluid at the cage and they are not reversible.

CHECK-VALVE PARTS

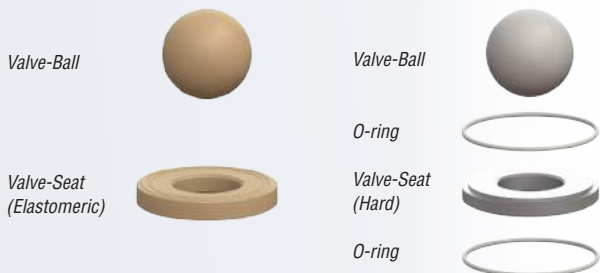

Elastomeric valve-seats do not require O-rings to seal and are reversible.

Hard valve-seats require O-rings to seal against the cage.

CHECK-VALVES MATERIALS

CHECK-VALVE MATERIAL Characteristics

Nitrile (Buna-N)	Excellent for Petroleum-based fluids.
FKM (Viton®)	Excellent for high temperature applications. Good with some aggressive fluids. High cost price.
Hytrel®	Excellent for general purpose. For abrasive but non-corrosive fluids. High flex life.
Santoprene®	Good for mild acids or caustics. For abrasive fluids. For low temperatures - Best low price.
PTFE (Teflon®)	Excellent for highly aggressive fluids including strong solvents, hydrocarbons, acids and caustics. High cost price.
Stainless Steel 316	Excellent for highly aggressive fluids, including strong solvents, some acids and caustics. High cost price.



SEAT SELECTION

SEAT MATERIAL	Color	Cost Price	Abrasion Resist.	Acid Resist.	Caustic Resist.	Solvents (Ketones/Acetates)	Hydrocarbons (Aromatic/Chlorinated)	Petroleum Oils
Nitrile (Buna-N)*	Black	\$\$	B	D	C	C	C	A
Hytrel®**	Cream	\$\$	A	C	C	B	C	A
Santoprene®**	Tan	\$	A	B	B	B	D	D
Polypropylene**	White	\$	C	A	A	B	D	D
PTFE (Teflon®)**	White	\$\$\$\$	C	A	A	A	A	A
Aluminium**	Metallic	\$\$\$	B	F	F	A	F	A
Stainless Steel 316**	Metallic	\$\$\$\$	C	B	B	A	A	A
Stainless Steel 440** Hardened (on request)	Metallic	\$\$\$\$\$	A	C	C	B	B	A

A = Excellent – B= Good – C= Fair – D= Poor – F=Not recommended.

* : Soft-type valve seats (elastomeric) do not require additional "o-rings" – Reversible design.

** : Hard-type valve seats require adequately selected "o-rings" to provide tightness between the seat and the housing.

Valve seat "O-rings" available in Nitrile, EPDM, FKM (Viton®) and PTFE (Teflon®).

BALL SELECTION

BALL MATERIAL	Color	Cost Price	Abrasion Resist.	Acid Resist.	Caustic Resist.	Solvents (Ketones/Acetates)	Hydrocarbons (Aromatic/Chlorinated)	Petroleum Oils
Nitrile (Buna-N)	Black	\$\$	B	F	F	C	C	A
FKM (Viton®)	Black+Yellow	\$\$\$\$\$	B	A	A	D	A	A
Hytrel®	Cream	\$\$	A	D	D	B	C	A
Santoprene®	Tan	\$\$	A	B	B	B	D	D
PTFE (Teflon®)	White	\$\$\$\$	C	A	A	A	A	A
Stainless Steel 316	Metallic	\$\$\$\$\$	A	B	B	A	A	A

A = Excellent – B= Good – C= Fair – D= Poor – F=Not recommended

Always check chemical compatibility of the selected materials.

DIAPHRAGMS SPECIFICATIONS

WETTED PARTS SPECIFICATIONS

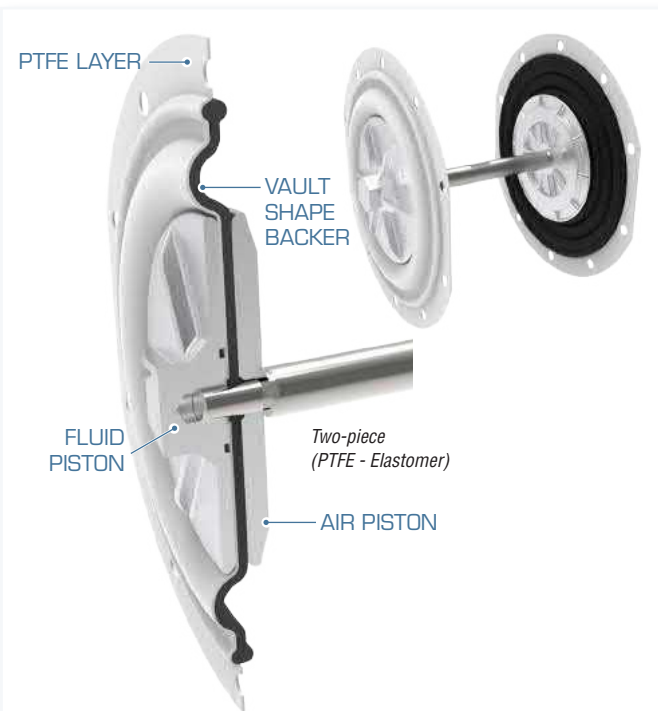

TWO-PIECE (PTFE-ELASTOMER) TYPE

- Laminated PTFE layer for use with aggressive chemicals.
- PTFE layer design and material properties provide excellent flex-life.
- Annular-Vault shape design in diaphragm and backer in Thermoplastic Elastomer for additional support.
- Extends diaphragm life.
- Exposed Fluid Piston, conventional design.

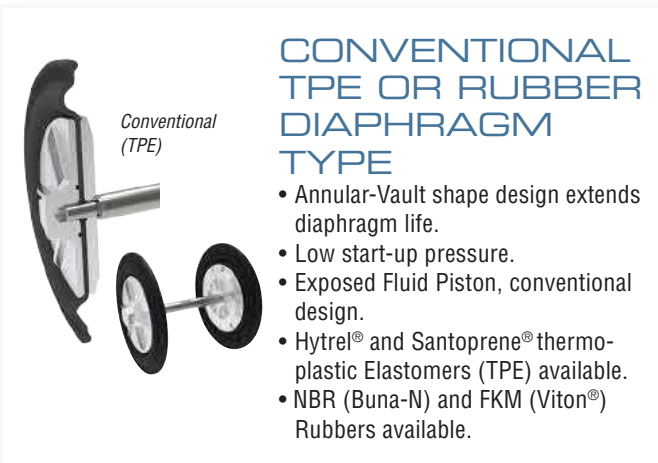

CONVENTIONAL TPE OR RUBBER DIAPHRAGM TYPE

- Annular-Vault shape design extends diaphragm life.
- Low start-up pressure.
- Exposed Fluid Piston, conventional design.
- Hytrel® and Santoprene® thermoplastic Elastomers (TPE) available.
- NBR (Buna-N) and FKM (Viton®) Rubbers available.

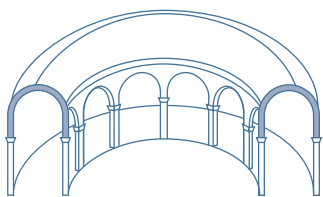

ANNULAR VAULT STRUCTURAL DESIGN

Suitable to withstand high loads if uniformly applied.

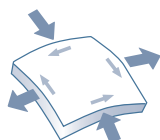

OVERMOLDED DIAPHRAGM TYPE

- Single piece diaphragms present the following advantages:
- Safety: No exposed piston to trap particles that could wear the diaphragm. Minimized product contamination risk.
 - Clean: smooth contours. No exposed piston.
 - Durability: excellent flex life.
 - No central hole nor tight torque required. Leak free.
 - Quick, safe and easy diaphragm replacement.

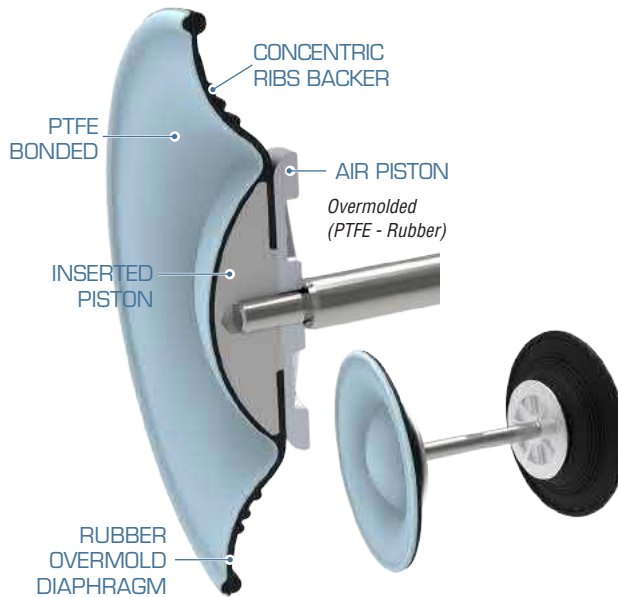

OVERMOLDED PTFE-RUBBER DIAPHRAGMS

- Inserted piston overmolded with Thermoset Rubber (EPDM).
- Dome shape design with back-up concentric ribs to give extra support with each diaphragm flexion.
- PTFE bonded layer in contact with the fluid for pumping aggressive chemicals.
- Temperature range: -5 °C to +130 °C.



OVERMOLDED TPE DIAPHRAGMS

- Inserted Piston overmolded with Thermoplastic Elastomer (TPE).
- Annular-Vault shape design extends diaphragm life.
- Improved suction life and flow (compared to the two piece PTFE -Elastomer conventional diaphragms).
- Durability: Excellent flex life, temperature resistant.
- Available in Hytrel® and Santoprene®.



OVERMOLDED RUBBER DIAPHRAGMS

- Inserted Piston overmolded with Thermoset Rubber.
- Dome shape design with back-up concentric ribs to give extra support with each diaphragm flexion.
- Versatile, general purpose materials.
- Available in NBR (Buna-N) and FKM (Viton®).

DIAPHRAGM MATERIALS

ELASTOMER MATERIAL	Characteristics
Nitrile (Buna-N)	Excellent for Petroleum-based fluids.
FKM (Viton®)	Excellent for high temperature applications. Good with some aggressive fluids. High cost price.
Hytrel®	Excellent for general-purpose transfer applications. Ideal for abrasive and non-corrosive fluids. Provides excellent flex-life.
Santoprene®	Good with mild acids or caustics. Good abrasion resistance and wider chemical compatibility. Provides high flex-life. Good choice for low temperature applications. Most economic diaphragm material.
PTFE (Teflon®)	Excellent for highly aggressive fluids including strong solvents, acids, caustics. High cost price.



DIAPHRAGM SELECTION

DIAPHRAGM MATERIAL	Color	Cost Price	Flexion Resist	Abrasion Resist	Chemical Resist	Temperature Resist	Temperature Limits* °C	Temperature Limits* °F
Nitrile (Buna-N)	Black	\$\$\$	A-	B	C	C	-23°/+82°	-10°/+180°
FKM (Viton®)	Black	\$\$\$\$\$	A	C	A	A+	-40°/+177°	-40°/+350°
Hytrel®	Cream	\$\$	A	A+	C	B	-29°/+104°	-20°/+220°
Santoprene®	Tan	\$	A+	A+	B	A+	-40°/+135°	-40°/+275°
PTFE/Santoprene® (Backer)	White / Green	\$\$\$\$	C	F	A+	A	-20°/+107°	-4°/+225°
PTFE/ EPDM (Bonded)	Blue / Black	\$\$\$\$\$	B	F	A+	A+	-10°/+107°	-4°/+225°

A= Excellent, B= Good, C= Fair, D= Poor, F= Not recommended.

(* Maximum temperature limits are based on mechanical stress resistance only. Certain chemicals can significantly reduce the maximum temperature limits.

DIAPHRAGM DESIGN

DIAPHRAGM DESIGN	FLUID TYPE					MOUNTING		REQUIRED DUTY		SERVICE
	Water	Solids charged	Abrasive	High Viscous	Common Fluid	W/Inlet Pressure	Suction Lift	Intermittent	Continuous	Maintenance
Conventional (TPE)	A	A	A	B	A	A	A	A	A	B+
Two-Piece (PTFE/Santoprene®)	A	B+	C	B	A	A	B+	A	B+	B+
Overmolded (TPE)	A+	A+	A+	A+	A+	A+	A	A+	A+	A+
Overmolded (Rubber)	A+	A	B	A+	A+	A+	A+	A+	A+	A+
Overmolded (PTFE/ EPDM)	A+	A+	C+	A+	A+	A+	A	A+	A+	A+

A= Excellent, B= Good, C= Fair.

Please note that excessive inlet pressure or excessive suction lift can shorten diaphragm life.

Always check chemical compatibility of the selected materials.

2" METALLIC PUMPS

The 2" (51 mm) Air Operated Double Diaphragm Pumps made of cast metal can reach a flow rate of up to 650 l/min (172 gal/min) and they offer a wide range of construction materials and porting configurations. The pump design ensures high abrasion resistance when pumping abrasive media and low flow resistance. Opposite inlet and outlet ports as standard. The discharge and inlet manifolds can rotate 180° for maximum pump installation versatility. These pumps are often used for transferring, filling, recirculating and batch dispensing in a variety of industries.

MAIN APPLICATIONS

- CERAMIC & PORCELAIN
- PAINT & VARNISH INDUSTRY
- OIL & GAS / PETROCHEMICAL
- WASTE WATER / WATER TREATMENT
- MARINE & SHIPBUILDING
- FILTER PRESS
- MINING & CONSTRUCTION
- CHEMICAL / PROCESSING
- PULP AND PAPER / CARDBOARD



Non contractual pictures.

TECHNICAL DATA

UP20 METALLIC PUMPS

Pressure Ratio	1:1
Maximum Free Delivery	650 l/min (172 US gal/min)
Air pressure range	1,5 to 8 bar (20 to 120 psi)
Solids in suspension, Max. size	6,4 mm (1/4")
Max dry suction lift	5 m (16')
Max wet suction lift	8 m (26')
Displacement per cycle*	5,1 l (1.35 gal)
Fluid inlet/outlet ports (Female)	2" NPT (F) Threaded 2" BSP (F) Threaded 2" ANSI/DIN Flanged
Air Inlet Port (Female)	3/4" BSP (F) 3/4" NPT (F)
Air Exhaust Port (Female)	1 1/2" NPT (F)
Sound level	85 dB (A) @ 50 cycles/min @ 70 psi
Weight (Aluminium version)	46 kg (101 lb)
Weight (Ductile Iron version)	74 kg (163 lb)
Weight (Stainless St. version)	76 kg (168 lb)

* Delivery per cycle depends on the diaphragms material, air inlet pressure and fluid viscosity.

PUMP NOMENCLATURE

Example: **UP20A-BSS-TTZ**

UX20X		XXX			XXX		
PUMP TYPE	AIR BODY	WETTED PATH		VALVES & DIAPHRAGMS			
1 Pump Type & Size	2 Center Body & Air Chambers	3 Fluid Ports / Location	4 Fluid Chambers & Manifolds	5 Hardware Bolts	6 Valve Seats	7 Valve Balls	8 Diaphragms Type & Material
UP20 Universal Pump (Bolted)	Ⓢ ATEX Certified A* = Aluminium L* = Conductive polypropylene with Stainless Steel air chambers	B = 2" BSP Threaded Ports / Centre horizontal C = 2" ANSI/DIN Flanged Ports / Centre Horizontal N = 2" NPTF Threaded Ports / Centre Horizontal	Ⓢ ATEX Certified A* = Aluminium F* = Ductile Iron S* = Stainless Steel	C = Carbon Steel S = Stainless Steel	A = Aluminium D = AISI 440 Hardened Stainless Steel H = Hytrel® M = Santoprene® N = Nitrile (Buna-N) S = AISI 316 Stainless Steel T = PTFE (Teflon®)	H = Hytrel® M = Santoprene® N = Nitrile (Buna-N) S = AISI 316 Stainless Steel T = PTFE (Teflon®) V = FKM (Viton®)	Conventional A = Santoprene® C = Hytrel® G = Nitrile (Buna-N) V = FKM (Viton®) Two-piece Z = PTFE (Teflon®) with Santoprene backer) Overmolded H = Hytrel® M = Santoprene® N = Nitrile (Buna N) T = PTFE / EPDM (Bonded)

* Ⓢ ATEX Certified pumps for use in hazardous locations ATEX Group II 2GDx.

Hytrel® is a registered trademark of the DuPont Company, Viton® & Teflon® of the Chemours Company and Santoprene® of the Monsanto Company, licensed for Advanced Elastomer Systems, L.P. Kyna® is a registered trademark of Arkema, Inc.

2" (51 mm) METALLIC PUMPS: DIMENSIONS AND PERFORMANCE CHARTS

UP20 ALUMINIUM FLANGED PUMPS

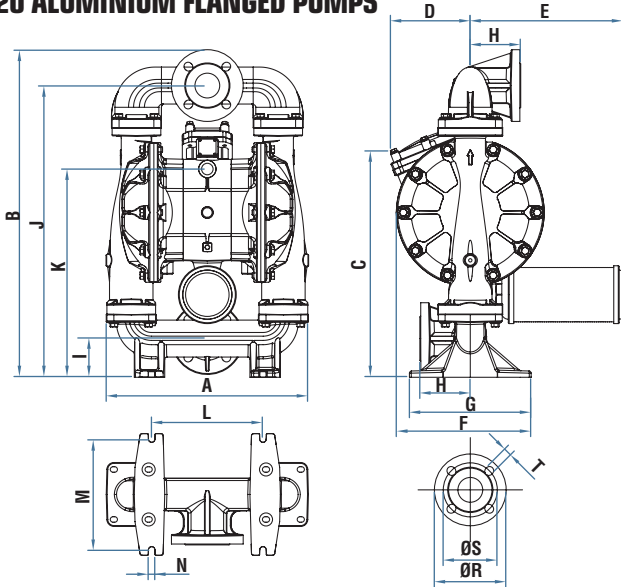

UP20 ALUMINIUM THREADED PUMPS

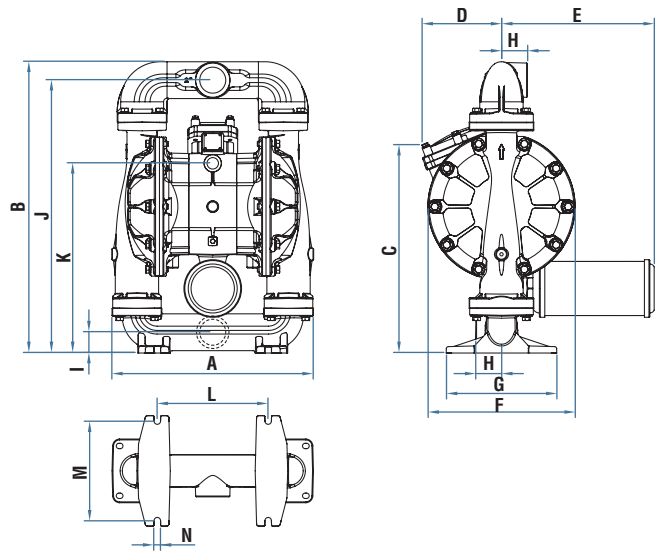

UP20 STAINLESS STEEL/IRON FLANGED PUMPS

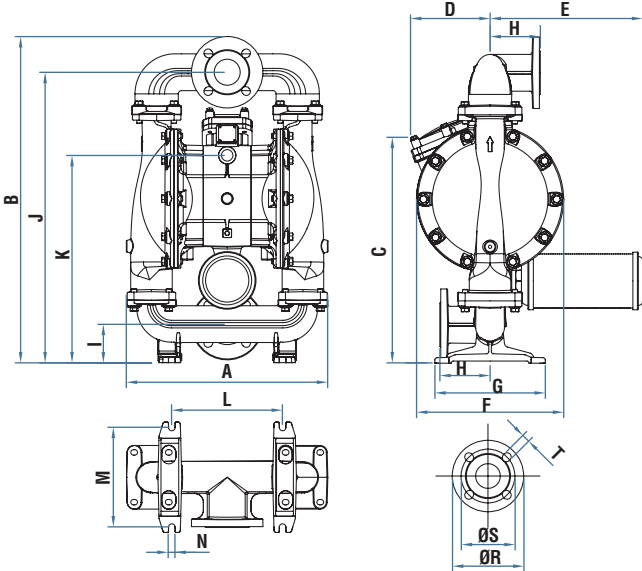

UP20 STAINLESS STEEL/IRON THREADED PUMPS

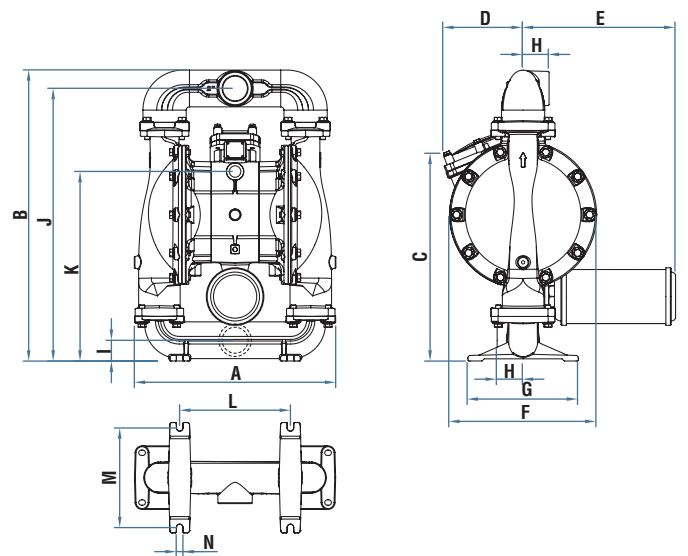

DIMENSIONS (mm)	A	B	C	D	E	F	G	H	I	J	K	L	M	N	R	S	T
UP20 FLANGED PUMP	465	754	251	184	353	340	255	116	89	671	479	256	230	15	165	120,6-125	19
UP20 THREADED PUMP	465	672	480	184	353	340	255	60	48	630	438	256	230	15	-	-	-

DIMENSIONS (inches)	A	B	C	D	E	F	G	H	I	J	K	L	M	N	R	S	T
UP20 FLANGED PUMP	18 5/16	29 11/16	9 7/8	7 1/4	13 57/64	13 25/64	10 3/64	4 9/16	3 1/2	26 27/64	18 55/64	10 5/64	9 1/16	19/32	6 1/2	4 3/4-4 59/64	3/4"
UP20 THREADED PUMP	18 5/16	26 29/64	18 57/64	7 1/4	13 57/64	13 25/64	10 3/64	2 23/64	1 57/64	24 51/64	17 1/4	10 5/64	9 1/16	19/32	-	-	-

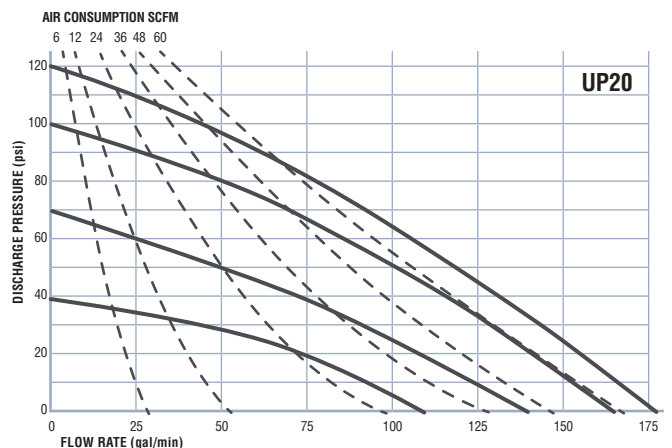
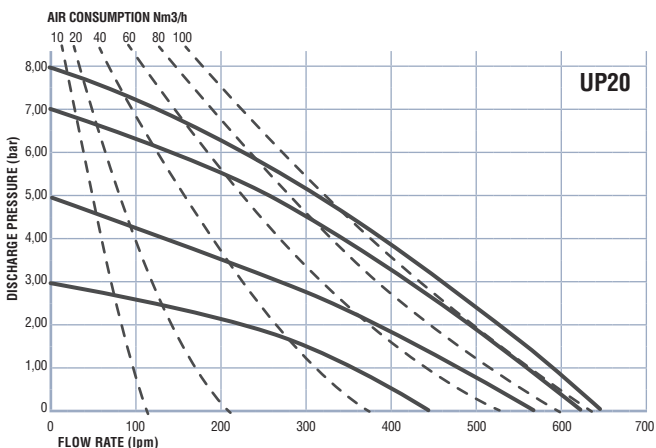

Performance charts with water at room temperature (20 °C - 70 °F)

2" NON-METALLIC PUMPS

The 2" (51 mm) Air Operated Diaphragm Pumps made of injected moulded plastic parts can reach a flow rate up to 650 l/min (172 gal/min). They are available in natural or conductive polypropylene and PVDF for optimum fluid compatibility and corrosion resistance.

Lateral offset inlet and outlet ports to avoid eventual material leaks onto the pump footprint. The discharge and inlet manifolds can rotate 180° for maximum pump installation versatility. The flanged bolted ports meets both DIN and ANSI standards.

These pumps are used for transferring, filling and batch dispensing in a variety of industries.



Non contractual picture.

MAIN APPLICATIONS

- OIL & GAS/PETROCHEMICAL
- PAINT & COATING INDUSTRY
- CHEMICAL PROCESSING
- WASTE WATER/WATER TREATMENT
- FILTER PRESS (WATER DISPOSAL)
- PLANT & MECHANICAL ENGINEERING
- PULP & PAPER/CARDBOARD
- POWER STATIONS (ENERGY)
- TANK FARM/BULK TRANSFER

TECHNICAL DATA

UP20 NON-METALLIC PUMPS

Pressure Ratio	1:1
Maximum Free Delivery	650 l/min (172 US gal/min)
Air pressure range	1,5 to 8 bar (20 to 120 psi)
Solids in suspension, Max. size	6,4 mm (1/4")
Max dry suction lift	5m (16')
Max wet suction lift	8 m (26')
Displacement per cycle*	5,1 l (1.35 gal)
Fluid inlet/outlet ports (Flanged)	2"ANSI/DIN. Side Ends.
Air Inlet Port (Female)	3/4" BSP (F)
	3/4" NPT (F)
Air Exhaust Port (Female)	1 1/2" NPT (F)
Sound level	85 dB (A) @ 50 cycles/min @ 70 psi
Weight (Plastic version)	28 kg (62 lb)

* Delivery per cycle depends on the diaphragms material, air inlet pressure and fluid viscosity.

PUMP NOMENCLATURE

Example: **UP20B-FPS-PMA**

UX20X		XXX			XXX		
PUMP TYPE	AIR BODY	WETTED PATH		VALVES & DIAPHRAGMS			
1 Pump Type & Size	2 Central Body & Air Chambers	3 Fluid Ports / Location	4 Fluid Chambers & Manifolds	5 Hardware Bolts	6 Valve Seats	7 Valve Balls	8 Diaphragms Type & Material
UP20 Universal Pump (Bolted)	ATEX Certified B* = Conductive Polypropylene (black)	F = 2" ANSI/DIN Flanged Ports / Side Ends.	P = Polypropylene (white) W = PVDF (Kynar®) (graphite) ATEX Certified B* = Conductive Polypropylene (black)	S = Stainless Steel	P = Polypropylene T = PTFE (Teflon®)	H = Hytrel® M = Santoprene® N = Nitrile (Buna-N) T = PTFE (Teflon®) V = FKM (Viton®)	Conventional A = Santoprene® C = Hytrel® G = Nitrile (Buna-N) V = FKM (Viton®) Two-piece Z = PTFE (Teflon® with Santoprene backer) Overmolded N = Nitrile (Buna N) H = Hytrel® M = Santoprene® T = PTFE / EPDM (Bonded)

* ATEX Certified pumps for use in hazardous locations ATEX Group II 2GDx.

Hytrel® is a registered trademark of the DuPont Company, Viton® & Teflon® of the Chemours Company and Santoprene® of the Monsanto Company, licensed for Advanced Elastomer Systems, L.P. Kynar® is a registered trademark of Arkema, Inc.

2" (51 mm) NON-METALLIC PUMPS: DIMENSIONS AND PERFORMANCE CHARTS

UP20 NON-METALLIC FLANGED PUMPS

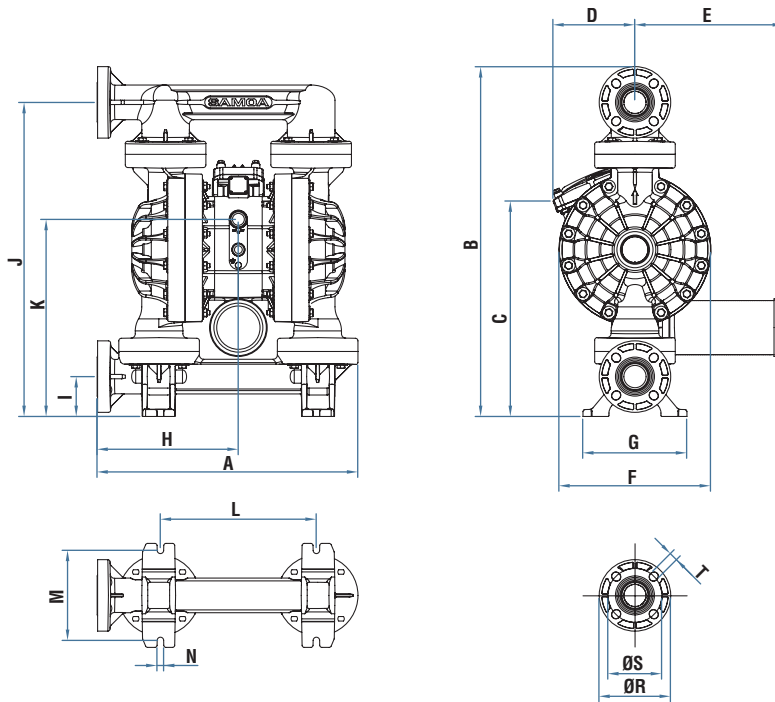

DIMENSIONS (mm)	A	B	C	D	E	F	G	H	I	J	K	L	M	N	R	S	T
UP20 FLANGED PUMP	602	808	497	189	344	350	240	326	92	725	455	360	208	15	165	120,5-125	19
DIMENSIONS (inches)	A	B	C	D	E	F	G	H	I	J	K	L	M	N	R	S	T
UP20 FLANGED PUMP	23 45/65	31 13/16	19 9/16	7 7/16	13 35/64	13 25/32	9 29/64	12 53/64	23/64	28 35/64	17 29/32	14 11/64	8 3/16	19/32	6 1/2	4 3/4-4 59/64	3/4

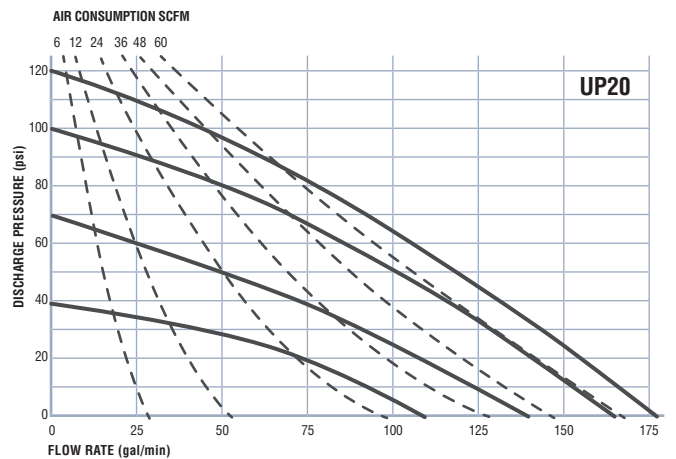
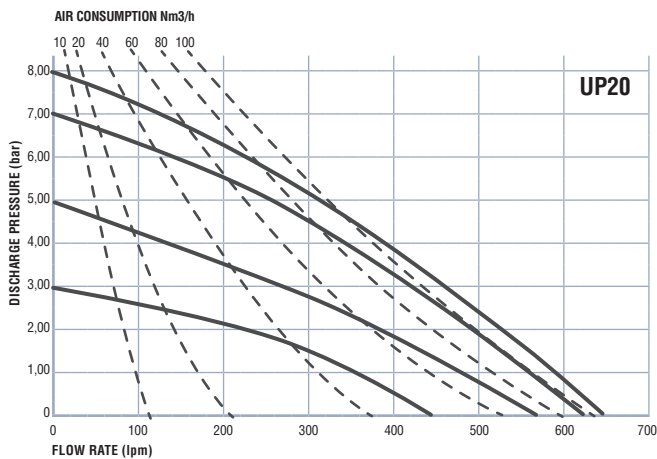

Performance charts with water at room temperature (20 °C - 70 °F)

3" METALLIC PUMPS

The 3" (76 mm) Air Operated Double Diaphragm Pumps made of cast metal can reach a flow rate of up to 1.000 l/min (264 gal/min) and they offer a wide range of construction materials and porting configurations. The pump design ensures high abrasion resistance when pumping abrasive media and low flow resistance. Opposite inlet and outlet ports as standard. The discharge and inlet manifolds can rotate 180° for maximum pump installation versatility. These pumps are often used for transferring, filling and batch dispensing in a variety of industries.



Non contractual picture.

MAIN APPLICATIONS

- CERAMIC & PORCELAIN
- PAINT & VARNISH INDUSTRY
- OIL & GAS / PTROCHEMICAL
- WASTE WATER / WATER TREATMENT
- MARINE & SHIPBUILDING
- FILTER PRESS
- MINING & CONSTRUCTION
- CHEMICAL / PROCESSING
- PULP AND PAPER / CARDBOARD

TECHNICAL DATA

UP30 METALLIC PUMPS

Pressure Ratio	1:1
Maximum Free Delivery	1.000 l/min (264 US gal/min)
Air pressure range	1,5 to 8 bar (20 to 120 psi)
Solids in suspension, Max. size	12,7 mm (1/2")
Max dry suction lift	6 m (19.7')
Max wet suction lift	8 m (26.2')
Displacement per cycle*	10,2 l (2.6 gal)
Fluid inlet/outlet ports (Female)	3" NPT (F) Threaded 3" BSP (F) Threaded 3" ANSI/DIN Flanged
Air Inlet Port (Female)	3/4" BSP (F) 3/4" NPT (F)
Air Exhaust Port (Female)	1 1/2" NPT (F)
Sound level	83 dB (A) @50 cycles/min @70 psi
Weight (Aluminium version)	68 kg (150 lb)
Weight (Stainless St. version)	120 kg (270 lb)

* Delivery per cycle depends on the diaphragms material, air inlet pressure and fluid viscosity.

PUMP NOMENCLATURE

Example: **UP30A-BAC-NNG**

UX30X		XXX			XXX		
PUMP TYPE	AIR BODY	WETTED PATH		VALVES & DIAPHRAGMS			
1 Pump Type & Size	2 Central Body & Air Chambers	3 Fluid Ports / Location	4 Fluid Chambers & Manifolds	5 Hardware Bolts	6 Valve Seats	7 Valve Balls	8 Diaphragms Type & Material
UP30 Universal Pump (Bolted)	ATEX Certified A* = Aluminium	B = 3" BSP Threaded Ports / Centre horizontal C = 3" ANSI/ DIN Flanged Ports / Centre Horizontal N = 3" NPTF Threaded Ports / Centre Horizontal	ATEX Certified A* = Aluminium S* = Stainless Steel	C = Carbon Steel S = Stainless Steel	A = Aluminium D = AISI 440 Hardened Stainless Steel H = Hytrel® M = Santoprene® N = Nitrile (Buna-N) S = AISI 316 Stainless Steel T = PTFE (Teflon®)	H = Hytrel® M = Santoprene® N = Nitrile (Buna-N) S = Stainless Steel 316 T = PTFE (Teflon®) V = FKM (Viton®)	Conventional A = Santoprene® C = Hytrel® G = Nitrile (Buna-N) V = FKM (Viton®) Two-piece Z = PTFE (Teflon® with Santoprene backer)

* ATEX Certified pumps for use in hazardous locations ATEX Group II 2GDx.

Hytrel® is a registered trademark of the DuPont Company, Viton® & Teflon® of the Chemours Company and Santoprene® of the Monsanto Company, licensed for Advanced Elastomer Systems, L.P. Kyna® is a registered trademark of Arkema, Inc.

3" (76 mm) METALLIC PUMPS: DIMENSIONS AND PERFORMANCE CHARTS

UP30 ALUMINIUM FLANGED PUMPS

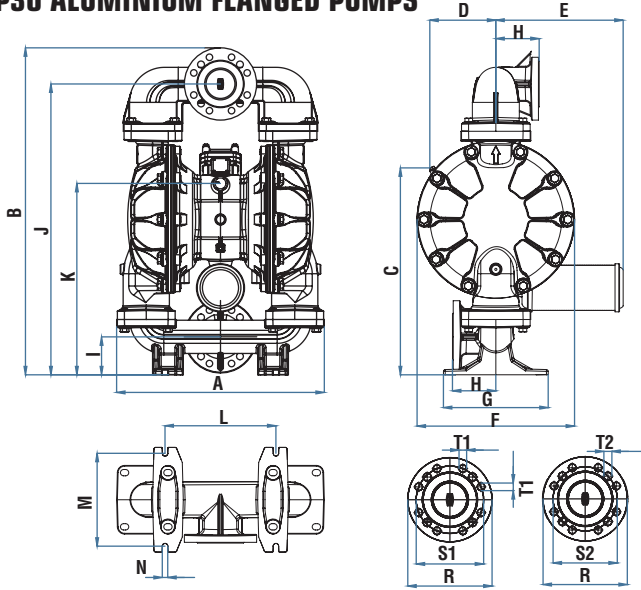

UP30 ALUMINIUM THREADED PUMPS

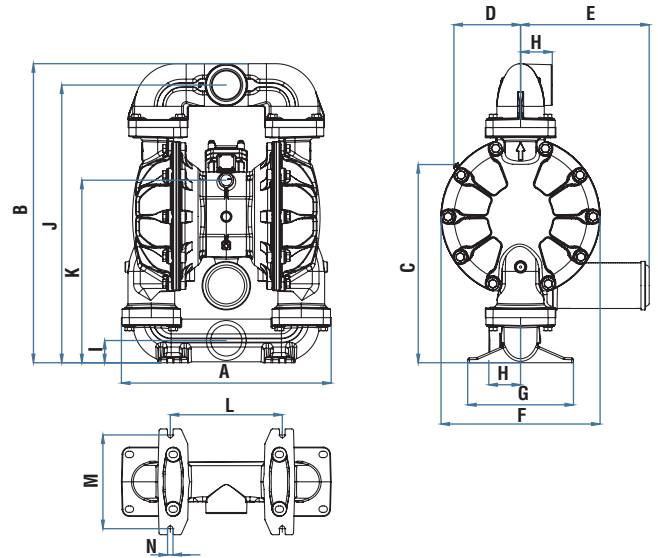

UP30 STAINLESS STEEL FLANGED PUMPS

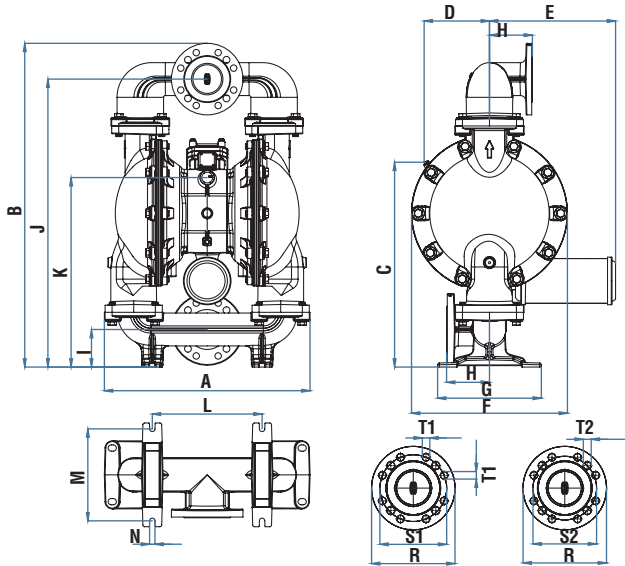

UP30 STAINLESS STEEL THREADED PUMPS

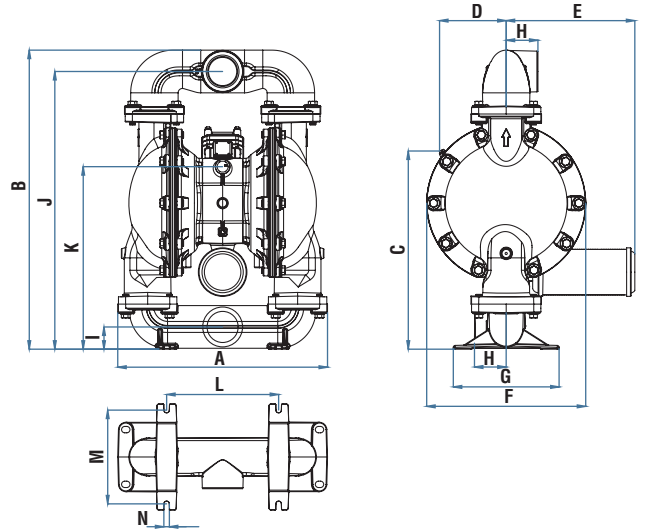

DIMENSIONS (mm)	A	B	C	D	E	F	G	H	I	J	K	L	M	N	R	S1 (DIN)	S2 (ANSI)	T1 (DIN)	T2 (ANSI)
UP30 FLANGED PUMP	575	905	573	184	353	436	290	120	105	805	530	307	257	15	200	160	152.5	18	19
UP30 THREADED PUMP	575	820	543	184	353	436	290	87	61	761	500	307	257	15	-	-	-	-	-

DIMENSIONS (inches)	A	B	C	D	E	F	G	H	I	J	K	L	M	N	R	S1 (DIN)	S2 (ANSI)	T1 (DIN)	T2 (ANSI)
UP30 FLANGED PUMP	21 105/64	35 5/8	22 9/16	7 1/4	13 57/64	17 11/64	11 27/64	4 47/64	4 5/32	31 45/64	20 14/16	12 3/32	10 1/8	19/32	7 7/8	6 5/16	6	23/32	3/4
UP30 THREADED PUMP	21 105/64	32 9/32	21 25/64	7 1/4	13 57/64	17 11/64	11 27/64	3 7/16	2 13/32	29 31/32	19 11/16	12 3/32	10 1/8	19/32	-	-	-	-	-

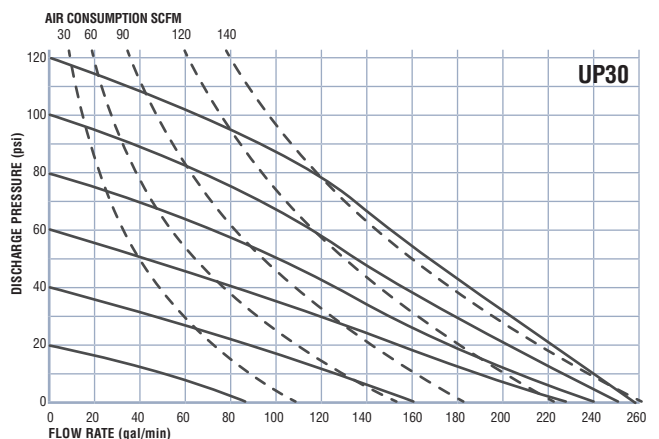
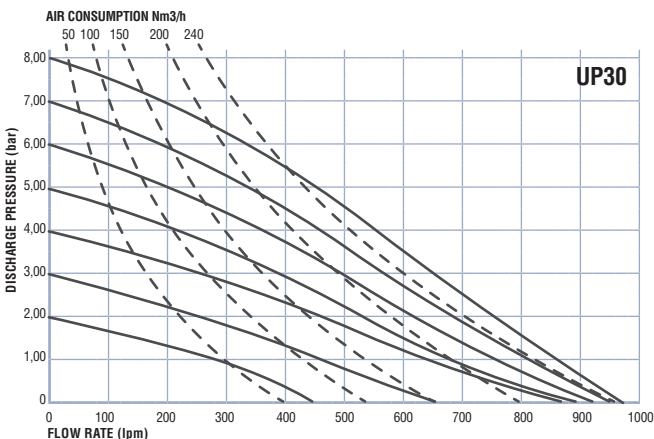

Performance charts with water at room temperature (20 °C - 70 °F)

ACTIVE PULSATION DAMPENERS

Air Operated Double Diaphragm Pumps have, at least, two points in their cycle where they do not supply pressure nor flow to the system. This originates pressure fluctuations and flow pulsations. An Active Pulsation Dampener, installed at the pump outlet, minimizes pressure fluctuation on the discharge end, providing a consistent laminar flow.

An Active Pulsation Dampener has an air chamber, connected to compressed air, that keeps a constant pressure on the diaphragm that divides the Dampener in an air and a fluid chamber. When the pump begins the discharge stroke, pressure in the line increases and flexes the diaphragm inward, accumulating fluid in the fluid chamber. Once the pump completes a stroke and redirects its motion, the pressure at the pump outlet decreases and the compressed air in the air chamber flexes the diaphragm outwards, displacing the accumulated fluid into the discharge line.

The dampener size and its materials (chambers and diaphragm) must be selected to be compatible with the corresponding pump.

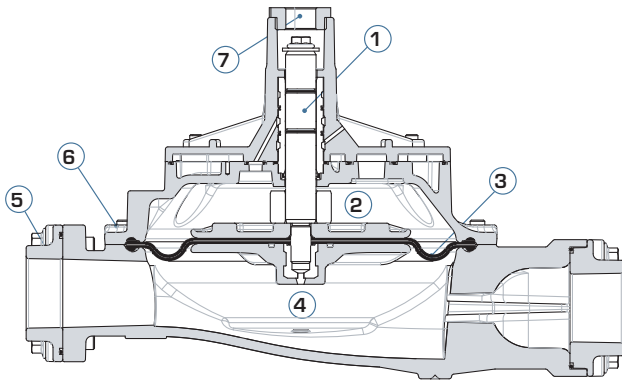

ACTIVE PULSATION DAMPENER

- ① Main valve
- ② Air chamber
- ③ Diaphragm
- ④ Fluid chamber
- ⑤ Fluid inlet/outlet ports NPT/BSP
- ⑥ Bolted fasteners
- ⑦ Air inlet

ADVANTAGES

- Stabilized discharge pressure
- Minimized flow pulsation
- No fluid foam formation
- No fluid splashing
- Less piping vibration
- Equipment protection in long pipe runs and valve protection.
- Bolted construction (leak free)
- Automatic air actuation (Active)
- Easy installation

INSTALLATION

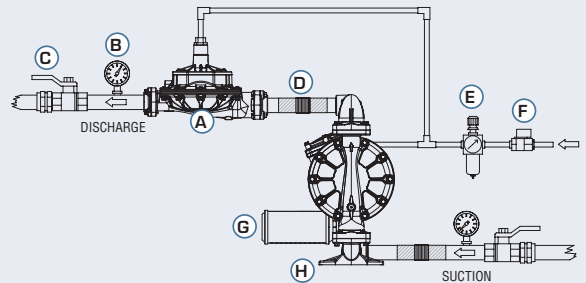

- Ⓐ Active Pulsation Dampener
- Ⓑ Gauge (optional)
- Ⓒ Shut-off Valve
- Ⓓ Flexible connection
- Ⓔ Filter Regulator
- Ⓕ Air Shut-off Valve
- Ⓖ Muffler
- Ⓗ Footpad

ACTIVE PULSATION DAMPENERS - NOMENCLATURE

APDXOX

XXX

X

Example: **APD20A - BAC - A**

PULSATION DAMPENER	AIR CONTROL SECTION	WETTED PATH SECTION		FLEXIBLE DIAPHRAGM	
1 Model Type & Size	2 Air Chamber Material	3 Fluid Ports	4 Fluid Chamber Material	5 Fasteners Bolts	6 Diaphragm Material
APD20 2" = 2,6 l. Max Volume For use with 1 1/2" & 2" pumps APD30 3" = 8,3 l. Max Volume For use with 3" pump	ATEX Certified A* = Aluminium B* = Conductive Polypropylene (black) F* = Ductile Iron S* = Stainless Steel	THREADED PORTS B = BSP (Female) N = NPT (Female) 2" FLANGED PORTS (Non-Metallic APD only) F = ANSI/DIN	P = Polypropylene (white) W = PVDF (Kynar®) (Dark Grey) ATEX Certified A* = Aluminium B* = Conductive Polypropylene (black) F* = Ductile Iron S* = Stainless Steel	C= Carbon Steel S= Stainless Steel	Conventional A = Santoprene® C = Hytrel® G = Nitrile (Buna-N) V = FKM (Viton®) Two-piece Z = PTFE(Teflon® with Santoprene backer)

* **ATEX Certified** for use in hazardous locations ATEX Group II 2GDx.
 3" APD available in Aluminium only.

Hytrel® is a registered trademark of the DuPont Company, Viton® & Teflon® of the Chemours Company and Santoprene® of the Monsanto Company, licensed for Advanced Elastomer Systems, L.P. Kynar® is a registered trademark of Arkema, Inc.

DIAPHRAGM PUMP MARKETS AND APPLICATIONS



OIL AND GAS. PETROCHEMICAL

- Loading and unloading of tanks, totes, and drums.
- Well stimulation - acidization.
- General utility transfer.
- Cellar pump-out.
- Oil spill clean-up / response.
- Drilling mud make-up.
- Glycol feed.
- Slurry transfer.
- Saltwater transfer and disposal.
- Fuel transfer.



CHEMICAL PLANT PROCESSING

- Loading and unloading tanks, totes and drums.
- Packaging.
- Acids, alkalis, esters, ethers, alcohols, solvents and polymers transfer.
- Dosing.
- Chemical effluent transfers.



MINING AND CONSTRUCTION

- Loading and unloading of tanks and totes.
- Fuel and lubricants transfer.
- Waste fluids and water evacuation.
- Dewatering.
- Cement additives mixing.
- Plaster spraying.
- Soil testing.



PAINTS AND COATINGS

- Loading and unloading of tanks, totes and drums.
- Pigments, solvents and resins transfer.
- Dosing of chemical additives
- Paint filtration.
- Solvent reclamation.
- Filling machines.



PULP AND PAPER

- Loading and unloading tanks, totes and drums.
- Paper treatment chemicals for deinking, chelation, filling, sizing, causticizing, strengthening, etc.
- Rosin, bleach and green liquor transfer.
- Additive dosing.
- Chemical recovery.
- Packaging.
- Starch preparation and transfer.
- Adhesives and ink transfer and dispensing.



TEXTILES, LEATHER & GARMENTS

- Loading and unloading tanks, totes and drums.
- Filter press.
- Dosing.
- Transfer of chemicals agents for desizing, scouring, bleaching, mercerizing, etc.
- Transfer of dyes, pigments, colours, etc.
- Colour formulation and colour spraying.
- Slurry transfer.
- Filtration.
- Effluent & wastewater disposal / dispensing.

DIAPHRAGM PUMP MARKETS AND APPLICATIONS



PLANT AND MECHANICAL ENGINEERING

- Loading and unloading tanks, totes and drums.
- Filtration.
- Cleaning processes.
- Metal refining.
- Surface treatment (galvanizing, zinc plating, etc.).



CERAMICS

- Mould filling and cleaning.
- Ceramic slip transfer.
- Glazing and glaze transfer.
- Filter press.
- Waste-water transfer and evacuation.



MARINE

- Loading and unloading tanks, totes and drums.
- Lubricants and fuel transfer.
- Seepage clean-up.
- Tank strip-outs.
- Dewatering.
- Bilge pumping.



POWER STATIONS (ENERGY)

- Loading and unloading tanks, totes and drums.
- Transfer of heat transfer fluids in solar plants.
- Water transfer and evacuation.
- Refrigeration.



TANK FARMS / BULK TRANSFER

- Loading and unloading tanks, totes and drums.
- Product storage.
- Field treatment.
- Fermentation.
- CIP (Solvent / Nitric Acid / Sodium Hydroxide) transfer.



WASTEWATER AND WATER TREATMENT

- Mobile water systems.
- Wastewater and sewage treatment.
- pH neutralization.
- Sludge removal.
- Irrigation.
- Sampling.
- Drum unloading for chemical injection skids.
- Filtration.



ELECTRONICS

- Loading and unloading tanks, totes and drums.
- Acid washing.
- Chemical treatment of wafers.
- Silicon slurry transfer.
- Wastewater transfer.





SAMOA INDUSTRIAL, S.A. - HEADQUARTERS

SPAIN AND EXPORT MARKETS
POL. IND. PORCEYO, I-14 - CAMINO DEL FONTÁN, 831
E-33392 GIJÓN (ASTURIAS), SPAIN
TEL.: +34 985 381 488 - FAX: + 34 985 147 213

SAMOA LTD.

UNITED KINGDOM AND REP. OF IRELAND
ASTURIAS HOUSE - BARRS FOLD ROAD
WINGATES INDUSTRIAL PARK
WESTHOUGHTON, BL5 3XP, UK
TEL.: +44 1942 850600 - FAX: +44 1942 812160

SAMOA S.A.R.L.

FRANCE
P.A.E.I. DU GIESSEN
3, RUE DE BRISCHBACH
67750 SCHERWILLER, FRANCE
TEL.: +33 3 88 82 79 62 - FAX: +33 3 88 82 77 88

SAMOA FLOWTECH GMBH

GERMANY, AUSTRIA, SWITZERLAND, THE NETHERLANDS AND
GREECE
AM OBEREICHHOLZ 4
D - 97828 MARKTHEIDENFELD, GERMANY
TEL.: +49 9391 9826 0 - FAX: +49 9391 98 26 50

SAMOA CORPORATION

NORTH AMERICA AND MEXICO
90 MONTICELLO ROAD
WEAVERVILLE, NC 28787, USA
TEL. +1 (828) 645-2290 - FAX: +1 (828) 658 0840

SAMOA CHINA SALES OFFICE

ROOM 702, RONG GUANG BUSINESS CENTER
572 KUN MING ROAD, SHANGHAI 200082, P.R. CHINA
TEL.: +86 21 3319 0210 - FAX: +86 21 5102 7883

SAMOA Industrial, S.A. is an ISO 9001, ISO 14001
and ISO 45001 certified company.



CONTACT US TODAY!

Visit www.samoaindustrial.com for more information.